

NOT an official Amstrad publication!!

HEROES OF THE LANCE

WIN
Second drive
Designer modem
Microne! subscription
and dozens of other prizes!



Full review plus great competition!

THIRD BIRTHDAY SPECIAL CASSETTE!

AA AND CODE MASTERS PRESENT AN OLIVER TWINS COLLECTOR'S EDITION!



DIZZY

22 FULLY PLAYABLE ROOMS!

ALL PROGRAMS TRANSFER EASILY TO DISK!

SMART II

- CREATE glorious technicolour art on your CPC

MICROASSEMBLER

- TRANSLATE assembly language into machine code

DISK FORMATTER

- RECOVER corrupted disks!

PLUS HELP FILES

- UNDERSTAND what this is all about!

THE MOULD-BREAKING MAGAZINE FROM FUTURE PUBLISHING

AA M S T R A D ACTION



inside: 36 AA teeshirts must be won!

MATCH DAY II



"The graphics are clear and realistically animated. The wealth of moves and tactics available put this game in a league of its own." C+VG

A CRASH Smash

"Match Day II has every option you could ever think of and loads more as well. The graphics are clear and well-animated. It's the best football game around." Crash

'AT LAST'

A WORTHY SUCCESSOR TO THE EVER POPULAR MATCH DAY FOOTBALL SIMULATION - A GAME WHICH HAS REMAINED IN THE READERS CHARTS FOR 3 YEARS!

Written once again by Jon Ritman and Bernie Drummond this NEW Match Day is the result of all the customer feedback and advice on how to create the pinnacle in computer soccer.

Pit yourself against the CPU or with 2 players - full league or cup competition with unique code - save facility. Jump, head, volley and kick (using the kick meter) to move the ball from player to player with automatic deadball set ups and goalkeeper control.

DIAMOND DEFLECTION SYSTEM™ ensures realistic ball ricochet and the action comes with full music and sound FX.

If you want the very best in football for your micro then there's only one choice... **MATCH DAY II** with multi-menu system makes the home computer come alive.



ocean is the registered trademark of Ocean Software Limited

ALIENS... THE GOOD...

KONAMI
COIN-OP ACTION



THE VINDICATOR



Beyond infinity lies the evil galaxy dominated by the forces of the despotic SALAMANDER. A hero must persuade his compatriots to join him on a journey into hell and beyond. Organic Monsters of destruction, Nuclear Spiders, Infernos burning like raging seas in torment, Covers of Despair, Demons beyond the dimensions of our minds.

SPECTRUM
£7.95 EACH
SPECTRUM
AMSTRAD
£8.95 EACH
COMMODORE

ALIEN FORCES WREAK HAVOC ON OUR PLANET. THE EARTH TORN AND BLASTED IN WHAT SEEMED THE FINAL WAR. BUT ENOUGH SURVIVED TO UPHOLD THE LAWS OF JUSTICE AND REVENGE. NOW ONE MAN MUST FACE THE FINAL ENEMY. HE IS THE VINDICATOR. ACROSS A TORTURED LANDSCAPE AGAINST INCREDIBLE ODDS HE MUST BATTLE THROUGH TO THE ENEMY STRONGHOLD. DOWN INTO MAZE LIKE CORRIDORS FILLED WITH MUTATED GUARDIANS UNTIL HE REACHES THE INNER SANCTUM OF THE DARK OVERLORD TO STRIKE THE FINAL BLOW OF RETRIBUTION. BECOME THE VINDICATOR IN THIS MULTI-SECTIONED GAME OF SURVIVAL AS STATE-OF-THE-ART GRAPHICS TAKE YOU ON THE ADVENTURE OF A LIFETIME. STRIKE BACK, BEFORE IT'S TOO LATE!

SALAMANDER

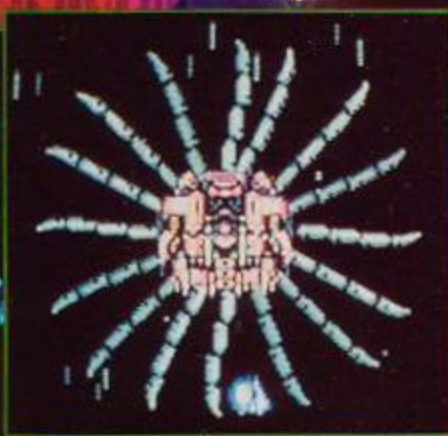
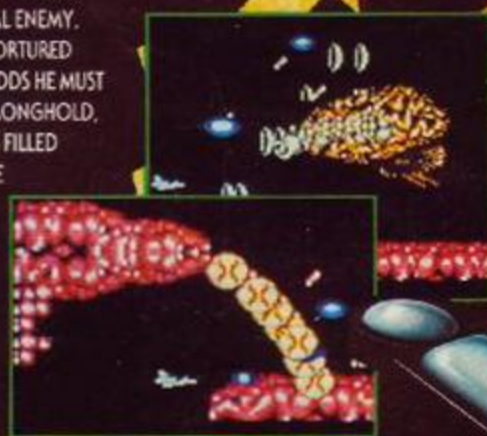

...the name
of the game

©Konami

COME AND SEE US ON
STAND No 3101 THIS YEAR AT
THE
PERSONAL
COMPUTER
SHOW
14th-18th SEPTEMBER
EARL'S COURT, LONDON

...AND THE EVIL!

THE LINE-UP

AMSTRAD ACTION • SEPTEMBER 1988

FRONT END

NEWS • LETTERS

07 REACTION

Complaints, observations, informations, questions, ramblings – AA readers say it all. *Sugarman* rounds things off nicely.

10 AMSCENE

News, upcoming releases, roundup of the new budget titles – if it's happening it's here.

15 AA BIRTHDAY COMPETITION

Happy birthday to us... Help us celebrate. There's dozens of prizes, and we've just got to give them away!



16 AA BIRTHDAY COVER CASSETTE

It's all here – a full list of everything that's on it, complete with details of how to run it.



27 AA IS THREE!

A special look back at the many highs and the occasional bloopers that are the milestones in an illustrious magazine's history.

SERIOUS SIDE

SOFTWARE • HARDWARE • PROGRAMMING

28 ABSOLUTE BEGINNERS

Basic from scratch.

12 PROBLEM ATTIC

Stuck? We'll sort it out in the Attic.

19 FIRST BYTES

If you aspire to assembler programming, do it here.

BAR CPM

Richard Monteiro continues *The Complete Guide to CPM*. Hardened hackers, as always, have something to keep them busy.

23 HARDWARE PROJECT

Stereo, stereo for your CPC, CPC!

28 THE INSIDER

We boldly go inside the *Multiface* with Romantic Robot's latest hacking aid. PLUS the secret of eternal life.

49 THE LOOK

The beginning of a brand new graphics series, taking you from square one.

ACTION & ADVENTURE

GAMES • MAPS • PILGRIM

35 ACTION TEST BEGINS WITH SKATE CRAZY

The first roller-skater simulation (we reckon!). Perform before judges – but how does the game itself match up?

36 PHM PEGASUS

Electronic Arts present a strategy/simulation that places you in command of a Patrol Hydrofoil Missilecraft. How does it do? Well, when we tell you it scores 29% in one department...

38 HEROES OF THE LANCE – MASTERGEAR

This is the one the AD&D'ers have been waiting for. Set in Krynn, the world of TSR's *Dragonlance* cult, *Heroes* involves you recovering the 'Disks of Mishakal'.



30 HEROES OF THE LANCE COMPETITION

US Gold and AA combine to bring you prizes to remember – a weekend for two at a very special castle (ever slept in a medieval bedchamber?), PLUS sixty seconds software smash and grab. For the lucky losers there's a MOUND of TSR *Dragonlance* books, a HEAP of copies of *Heroes of the Lance*, AND sets of the great new TSR's 'Dragonlance' boardgame.



40 GUNSHIP

Microprose at last unveil the simulation on the CPC: take to the air in an Apache AH-64 helicopter. Like Vietnam never happened...



43 AND MORE..

Also in this month's jam-packed *Action Test* we have full and detailed reviews of *Action Force*, *Bionic Commando*, and *ATV*.

59 THE PILGRIM

Adventurer? Come hither. The cloaked one has an exclusive report on the future of adventuring on the CPC, together with *Clue Sniffing* and *Lords and Ladies*. There is no alternative.

INTERACTION

FOR THE PEOPLE • BY THE PEOPLE

19 HOT TIPS

If you've discovered a nifty trick or tactic, don't keep it to yourself - after all, you could earn yourself £20 just for passing it on!

52 TYPE-INS

Five pages of listings to entertain, educate and occasionally amaze you. And quality is guaranteed, because we pay as much as £100 if a program really wows us!

WRAPPING UP

THINGS TO BUY • BYE!

64 CHEAT MODE

Another sizzling selection of the slickest pokes around - plus a full-page colour *Dark Side* map.

51 CLASSIFIED ADS

You're looking for cheap hardware? You've come to the right place...

68 GAMES INDEX

Get this: an index of every single game ever reviewed in AA! All complete in this month's 'Buyers' spot.

71 SPECIAL OFFERS

Outstanding offers on software, plus our extraordinarily generous subscription offer!

You ain't seen nothing yet!

Well, here it is: AA's third birthday issue. We celebrate with a very special cover cassette and some tremendous prizes in our great competition - and sales figures showing that more people are buying the magazine you are holding than ever before! We're pretty chuffed about that, and with your assistance, co-operation and loyalty we firmly expect to be around for a long time yet.

There are some great games titles coming out on the CPC in time for Christmas - not least of them *Heroes of the Lance*, reviewed in full in this issue. There are other things in store too, which we'll tell you about as soon as we possibly can.

All in all it's been a remarkable month here at AA. Stay with us, won't you, and join in the fun?

Steve

Oops! Somewhere along the line something went wrong last month - as about 35,095 of you seem to have noticed. September was issue 36, not 35 (again!) as we said.

Amstrad Action
Future Publishing Limited
4 Queen Street
Bath BA1 1EJ

Telephone 0225 446 034

Fax 0225 446 019

Editor: Steve Carey

Technical Editor: Pat McDonald

Staff Writer: Gary Barrett

Art Editor: Ollie Alderton

Contributors: Richard Monteiro, Steve Cooke

Art Team: Sally Meddings, Kevin Hibbert

Publisher: Chris Anderson

Production: Diane Tavener, Claire Woodland,

Jenny Reid, Harriet Athay

Subscriptions: Avon Direct Mail

PO Box 1, Portishead, Bristol BF20 9EG

Telephone 0272 842487

Mail Order: Clare Bates

The Old Barn, Brunel Precinct, Somerton, Somerset TA11 7PY

Telephone 0458 74011

Advertisements: Margaret Clarke

Byrom House, 53 Brinksway, Stockport, Cheshire

Telephone 061 474 7333

Cover photographs: Stuart Baynes Photography, Bath. Tel: 0225 66343

Colour origination: Wessex Reproductions, 325 Wells Road, Bristol BS4 0QL

Printing: Redwood Web Offset, Yeomans Way, Trowbridge, Wilts

Distribution: Seymour Press, 334 Brixton Road, London SW9 7AG

ABC

©FUTURE PUBLISHING LTD 1988

Amstrad Action is an independent publication. The company producing it - Future Publishing Ltd - has no connection with Amstrad plc. We welcome contributions from readers but unfortunately cannot guarantee to return material submitted to us, nor can we enter into personal correspondence. We take great care to ensure that what we publish is accurate, but cannot be liable for any mistakes or omissions. No part of this publication may be reproduced in any form without our permission.

MEMBER OF THE
AUDIT BUREAU OF
CIRCULATIONS

35,095

January - June 1988

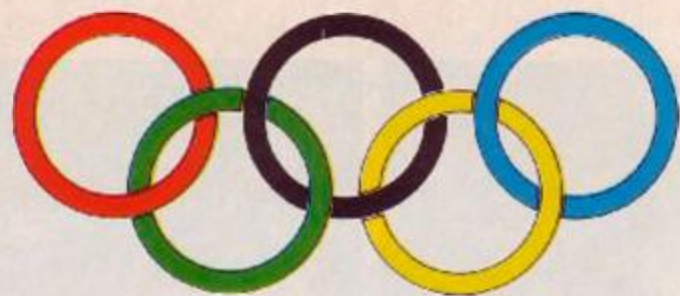

Will the Olympics come to Manchester?

WE WILL!

The gold medalist of computer shows is on its way back to Manchester's imposing G-MEX centre.

Amstrad and more than 70 other exhibitors will be displaying the latest products for you to try before you buy.

Need some technical help? Leading experts will be on hand throughout the three days to answer all your queries

With hundreds of special show offers available, every visitor could end up a financial winner.

You can even save yourself a £1 before you get there by using the advanced ticket order form.

How to get there

Driving? G-MEX is in the city centre - only one mile from the M602 - with ample parking available. It is also within easy reach of Victoria and Piccadilly railway stations, and Chorlton Street bus station.

AMSTRAD ST.

Be prepared for a warm welcome in "Amstrad Street" - a brand new show feature area, specially constructed for the event.

Take a stroll down the street and see how Amstrad machines are playing a major role behind the scenes in the current northern boom.

- Drop in on the "Amstrad Arms" our answer to the "Rover's Return".
 - Visit "Amstrad School" and observe how students in the north west are benefitting from the new technology.
 - Check out what's going on in a local company where Amstrad machines are providing them with the competitive edge.
 - Inspect the Amstrad innovation workshop.
- And much, much more.

It will be an unforgettable experience.

The Northern

AMSTRAD COMPUTER SHOW



October 21-23, 1988

FRI-SAT 10am-6pm - SUN 10am-4pm

Advance ticket order

G-MEX CENTRE, MANCHESTER. October 21-23, 1988.

Post to: Amstrad Show Tickets, Europa House, Adlington Park, Adlington, Macclesfield SK10 4NP.

Cheque enclosed made payable to Database Publications Ltd.

Please debit my credit card account

Access Visa

Adult tickets at £4 (save £1) £.....

U/16s tickets at £2.50 (save £1) £.....

TOTAL £.....

ADMISSION AT DOOR
ADULTS £5 U/16s £3.50

Advance ticket orders must be received by Wed, Oct 12, 1988.

Name

Address

Signed

PHONE ORDERS: Ring Show Hotline: 0625 879920

PRESTEL ORDERS: KEY *89 THEN 614568383

MICROLINK ORDERS: MAILBOX 72:MAG001

Please quote credit card number and full address

SAVE
£1

DATABASE EXHIBITIONS

A529

REACTION

Lots of doom and gloom this month, for some reason

● Gloom and doom

The interest of software houses in CPC games, it seems, is dying rapidly. Some examples: US Gold produced the dreadful *Outrun*. *Bionic Commandos* is in monochrome obviously ported over from the Spectrum, as was *Super Hang-On* from Activision. *Crazy Cars* from Titus had one level only while the other version had three. The Big Apple hopes to sell 250,000 games over all formats except Amstrad. Even Elite's latest *Hopping Mad* was a poor effort (compare it with the time they took over *Paperboy*).

Of course all Amstrad owners have to live with seeing the other format versions on the shelves weeks or even months beforehand.

The 6128 is an excellent computer and real value for money, but has never been given the software support it deserves. So with the upsurge in the 16-bit format this situation will get worse not better, as software houses with their 'loadsamoney' mentality will and do view the Amstrad as a poor return for their time and effort. Maybe it is no surprise to see 90% of the titles in the Amstrad top ten are budget



"IS IT JUST ME - OR DO PROGRAMMERS THESE DAYS SEEM TO BE EVEN YOUNGER"

releases! Do you think this Christmas will be the final fling for any worthwhile Amstrad software or am I being too pessimistic?

Steve Seager
Royston, Herts

You can't really complain about them doing it for the money - they are in business. They'll only change if they know they're losing out, so it's

● A little bitter philosophy

Upon finding myself drawn more and more towards my computer room due to several unfortunate occurrences, I realised that the computer is an escape from reality. I play on the computer so I can lock myself off from the outside world and forget my troubles, of which there are many. I can gain immense satisfaction from beating a few heads in - from enjoying myself and at the same time being able to lighten the weight on my mind.

S Jones
Latimer, Bucks

Sounds right gloomy to us. Surely not all us CPC'ers are desperate reality-escapists?

Still, perhaps the software winner voucher might cheer you up a little!

Penpals find a home

We're always getting letters from people who want AA readers as penpals (and who can blame them?), but we haven't been able to print them all.

Now we think we've found the perfect solution: *Helpline*. All penpal requests will automatically be included there, and of course will stay on the roster until you or your postman decide enough is enough. Hope that makes things easier for you would-be penpals!

● Could try harder

People do go on about how difficult games are becoming. I'm sure I'm not alone in saying that all the complexity is rapidly going out of games, and that the challenge is no longer there. Long term, non-repetitive games are dying out. The first day target is rapidly becoming a joke, and must, to most people, be a matter of a couple of minutes work. Even Incentive's brilliant and complex game *Dark Side* gave up all but the last telepod crystal in a mere four hours play (though *Freescape* does turn out to be all it is said to be). I hope software houses don't listen to the people wanting easy games.

James Moffatt
BFPO 20

Last month we had a letter from a games player complaining about the difficulty level: now one about the simplicity level. Just goes to show you can't please all the people all the time.

up to CPC owners to make it known they're sick to death of badly converted efforts.

Let the 16 bitters have their honeymoon: tomorrow they'll be just another breed of home computer, fighting for a slice of the market.

● Amstrad sea sense

I am excited about the DIY amplifier, but do you have to unplug other add-ons to use it? I saw two speech synthesisers advertised. After much thought I bought the Amstrad one, but I could not use CPM, so I wrote to Amstrad and they told me to unplug the speech synth when I was going to use CPM.

I am a 70 year old seaman, and all those years ago, when we were supposed to be stupid, nobody cast off a main halyard from a pin because they were setting a top'sl. It was rerouted through sheaves to another pin.

James Garsides
Airdrie, Scotland

You can leave the amplifier plugged in, and it won't interfere with the operations at all. I wouldn't leave it switched on though - the battery would go flat after a time. A small modification to allow the project to run off the Amstrad's power supply will be published in a future issue.

● Reaction, Amstrad Action, 4 Queen Street, Bath BA1 1EJ.

Note the address for all mail-order enquiries and orders is: Clare Bates, The Old Barn, Brunel Presinct, Somerton, Somerset TA11 7PY, while all subscription matters (except orders - see the back of the magazine) are handled by Avon Direct Mail, PO Box 1, Portishead, Bristol BF20 9EG.

Oh yes you are...

I am writing to complain about Bob Adams' letter (AA35). He appears to believe all CPC users under 16 are stupid games freaks with nothing better to do than sit in front of their monitors all day zapping aliens. Well, Mr Smartypants Adams, it gives me great pleasure to inform you that I am 11 and I don't sit in front of my 464 zapping monstertroids and thingtrons (though if you were on the screen I may oblige). I use my Amstrad to teach myself Basic and even the odd bit of machine code (yes, machine code, it may surprise you, but I do have the odd brain cell here or there). So, Mr Adams the younger generation may not be as wealthy as you, but we put our machines to good use without having to spend your average £14.66 per month, so now you know what to do with your 12% extra, don't you?

**John Winter
Stafford**

Charming. Look here, John, can't you see that you're at least as 'bad' as Mr Adams if you descend to this level of name-calling and pettiness? Why can't we have disagreements between ourselves without resorting to pulling hair and pinching? As we said last month, we need each other, and every CPC user is valuable to the future of the machine.

J. Public thwarted

I have been trying for months to get the free software handbook published by Peopletalk Publishers from my local library.

I have failed miserably: the library 'phoned the supplier direct and was told they only supply lots of 30. They do not deal in single copies therefore the book is not available to Joe

Public.

Your article led me into a very long-winded fruitless exercise. The chief librarian at my local library said he would be interested in the shape of your answer.

**P J Morley
Peterborough**

Davis/Rubin, it is true, are no longer importing the Free Software Handbook - though they used to. I suggest your librarian gets in touch with Peopletalk Associates direct (PO Box 863652, Plano, Texas 75086). Alternatively, steal young Richard Monteiro's copy.

If anyone knows of another source, we'd be delighted to hear from you.

A frayed knot

Is it possible using Multiface II to copy games like Gauntlet and Outrun where each level is loaded when the one before is finished?

**Donald Mackerracher
Portrush, Co Antrim**

Afraid not, because the disk or cassette must be accessed during play.

Renegade Pilgrim

I have just bought Target Renegade and I thoroughly enjoy it especially with two players. The graphics, sound and movement are excellent but I have one complaint. It says in the instructions that at 50,000 points and every 100,000 points after that you get an extra life.

It does this with player 1 but no matter how much score player 2 gets he doesn't get an extra life, so player 2 doesn't stand a chance of getting past level 5. Is this a bug or is it meant to be like this?

Also, when is Pilg's programming coming back?

Chris Marland

Corruption exposed

About four months ago I wrote a program which used the keyword *Chainmerge* to operate. The other day when I came to use the program after a while I got the **read fail** disk error message.

I have not got many disk utilities so I ran CPM and verified the disk, under Diskit It told me there was a disk error on track 2 sectors 0-8 and there was missing address mark, within system track.

What does this mean? Is my CF2 corrupted, if so how? Could you suggest any ways of recovering my program? How do I stop this happening to any of my other programs?

Nick Lawson

I'm afraid it looks very much as if your CF2 is corrupted - probably by stray magnetics, dust, heat on simply being dropped, all of which affect magnetic disks. Recovery of the section is difficult without a working knowledge of disks. I suggest you peruse Helpline. Although it's no consolation to you, Nick, perhaps we should take this opportunity to remind others once again that one can never tell when it will happen - always make backups of the masters you treasure.

First: the general opinion on Target Renegade is that it's a bug. Second: turn at once to this month's Ye Pilg, wherein thou shalt be mightily pleased (yes, I'm sorry too, but they talk like that over there).

Oops apologies

I feel I had to put pen to paper. In AA35's Cheat Mode you state to Phil Howard that he should, 'Move over and give someone else a chance'. I think this a very unfair statement to make to Phil, as there are hundreds of regular readers like me who depend on his excellent pokes. Without people like Mr Howard and Peter Featherstone there would be even fewer pokes in AA.

I know your reply to this will be, 'Yes, but they win games for their work'. Maybe they do - but how about printing a big thank-you from all your readers to these two special hackers?

**P. Hall,
Basildon, Essex**

Oh dear. For those of you who didn't see the offending remarks, what we actually said was: 'Really Phil, you ought to move over and give someone else a chance (mind you, it's all good stuff!)'. This was intended to be a joke, and we're sincerely sorry if anyone took offence - we know Phil didn't, because he's already sent in some more pokes, and we hope he'll be sending them

in and getting them printed for many, many issues to come.

What we were trying to do was simultaneously to congratulate Phil for the quality and quantity of his work - which we beg you to believe is appreciated - and at the same time to suggest that other readers should not think we have no time for them.

Butter problem

I was interested in the poke by Phil Howard for *Bubble Bobbie* giving infinite lives. This works fine for the 79 levels but you then have to rewind the tape for the 80th and fine level and the poke doesn't work.

Short. Sweet. But not cheap

Where can I buy a user manual?

**B Hfuhruhurr
Witton Gilbert, Durham**

You can buy user manuals for the 464, 664 and 6128 from CPC, 194-200 North Road, Preston, Lancashire PR1 1YP ☎ (0772) 555034. The price, which would bring tears to a glass eye, is £20 for each manual. Send cheques with order and be sure to specify which you require!

And they sell service manuals at £5 (464) and £8 (664/6128).

"WHY DIDN'T SOMEONE LET US KNOW GUMETT WAS ON HOLIDAY?"

Is there any way of destroying the dreaded Bonner who appears on the final level. If you or anyone out there can help I would be very grateful as I think I am beginning to develop brain damage through head-butting the monitor.

G Hanson

Giving a sucker...

Can you help me please! My joystick is a Cheetah MachI+ Microswitch Joystick and one of my suckers which sticks to the table (the four black things on the bottom of the joystick), has broken the knob off and it won't fit back on.

I wrote to them about three weeks ago but nothing came back.

Carl Wilson
Kenilworth, Warks

We spoke to them and they have no trace of your letter. Still, rite to them enclosing an SAE and they promise they'll swiftly give succour to your suckerless stick.

Perhaps when you wrote to them you forgot to enclose an SAE?

Race against type

On page 35 of the September AA (surely No 36 not No 35 on the cover (yes yes, alright, don't go on about it - blushing ed)) you say that the Race Against Time has two cassettes. I bought my copy in the local Woolworths a few months ago for the full price but I only have one cassette the same both sides. Have I the right to complain or are you wrong in your statement?

And finally, something cheerful!

Our local radio station (Radio City) had a competition, the prize being a trip to Ocean Software plus 21 games on disk. So both myself and a colleague entered and won.

Our host was the PR man Gary Bracey, whose assistant met us at the railway station and took us back to Ocean, where we watched (eyes popping) all the techniques that made up a program. We are both programmers but we saw things that we would never have dreamed of.

We saw how a game started off as just an idea. Then several programmers who were proficient in their own field coded the game sections, and pieced them together to form the complete version. They tweak up the 'playability' of the game and tailor it to what is believed to be the finished version ready for production. We saw music development, Art and graphic, sprite handling, you name it, we saw it.

Just before we were due to leave our railfare was refunded back to us and we were given a selection of games 'T' shirts and a priceless 'Ocean' mug. The director Colin Stokes wished to see us before we left to see how we found our tour of Ocean and we enjoyed ourselves! We discussed future plans, current plans, latest developments etc. one of them being Platoon and how Ocean won the film tie in rights. Not only did we get the game, we were given the LP sound track each plus a video each of the films.

Thank you Ocean Software and everybody there who made our visit such a happy and memorable one.

Grahame Campion & Keith Nicholson
Liverpool

Nice one Ocean - you've made friends for life.

I am sorry this is not typed but my typewriter packed up and I don't know whether to replace it or get an LQ/MLO type printer for the CPC 464 - would it be a waste of time? If not which program (cassette) would help me to type letters? Or should I first buy a disc drive?

Mrs C Jenkins
Newton, Wales

We all make mistakes (ahem ahem) and

yes, it's true, there's only one cassette in the Race Against Time.

I suggest you peruse the AA small ads or similar for a secondhand printer and Tasword 464 (the tape version). Tasman (☎ 0532 438301) supply this for £19.95. Don't bother with a disk drive until you really need it. A typewriter is cheaper as a one off, while the word processor program represents an investment.

Sugarman

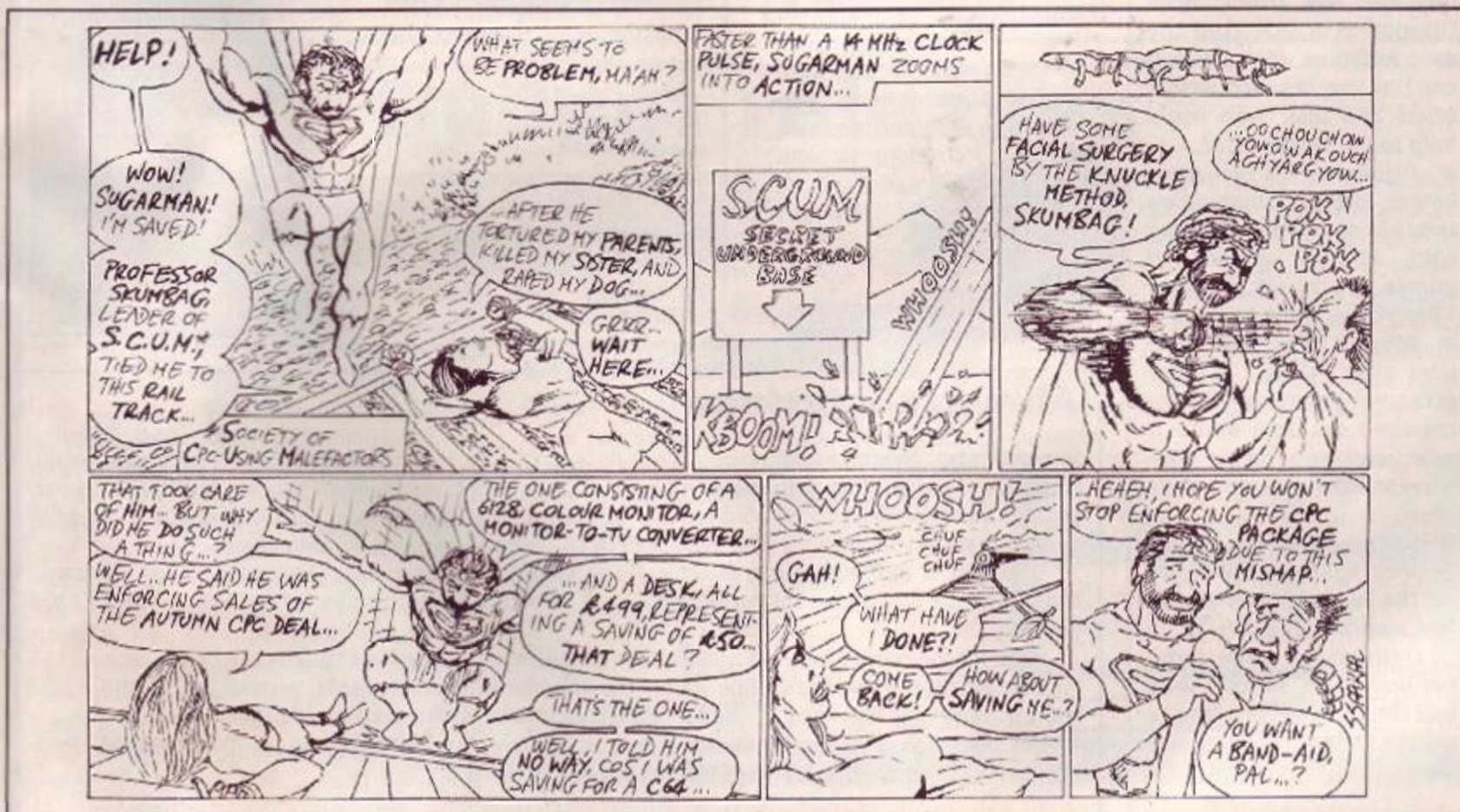

AMSCENE

CPC releases, news and information

New releases



● *The Train* – an accolade for Accolade?

Accolade are soon to release their first game through Electronic Arts, *The Train*, in which you play a French Resistance leader trying to seize an armoured train containing French treasures and guide it to safety in Normandy. The game's part shoot-em-up and part simulation, so you'll

need a combination of the two skills to do well. Out now at **£8.95 on tape** and **£14.95 cassette**. Look out for a full review next month!

Firebird have been quiet of late, but they're soon to start making noises again with *Savage*, scheduled for release in November at **£8.99 on tape** and **£14.99 on disk**.

Ocean present *Typhoon* and *Daley Thompson's Olympic Challenge*. The former is a simulation due for release in September – but a special version of the game, an arcade machine squeezed into a suitcase and is worth over £1,000, is also a prize on TV's *Wheel of Fortune*. On CPC

it's a positive bargain at **£8.95 on tape** and **£14.95 on disk**.

Daley Thompson's Olympic Challenge is also due for release – coinciding nicely with the Seoul goings-on – at **£9.95 on tape** and **£14.95 on disk**. It has the ten Olympic decathlon events featured in the original *Daley Thompson's Decathlon*, but there's also a workout in the gym beforehand.

Metaplex has just been released by Addictive – who brought you *Football Manager* and *Football Manager II*. Unusually for Addictive it's not a strategy but an arcade shoot-em-up: **£2.99 on tape**, **£6.99 on disk**.

Bits & CPC's

● Following a request in AA35 (er, that's AA35 mark one!) for programs using speech, we've heard about one by Edward Reid, who supplies it for £1 (p&p) plus a blank disk/tape: 157 Ladyloan Ave, Drumchapel, Glasgow G15 8RX. And the ever-welcome Joan Pancott can put you in touch with a blind CPC user who could help too ☎ 0305 784155.

● Remember us reporting Power House's impressive boast last month of having sold 250,000 copies of games in just six months? They've just gone bust...

● What a huge amount of post our Code Masters giveaway produced! Gary's crawling out from under it now, and you lucky winners should receive yours soon...

● We take this opportunity once again to apologise for the two major boo-boo's last month.

Getting the issue number wrong (35 twice?) was one thing, but printing a whole page of Type-Ins twice...!

Oh joys

Suncom launch two new joysticks, the Tac 30 and Tac 50 – upgrades of the Tac 3 and Tac 5 models, with microswitches and aircraft style handles. The Tac 30 is £13.99, the Tac 50 £14.99.

And Konix of Speedking fame have also added two to their range, the Predator and the Megablaster. The Megablaster is to sell for 'under £8' and the Predator 'under £14'.



● The Megablaster from Konix

Pirates ahoy

The Federation Against Software Theft (FAST) and members Glasgow's 'E' Division CID have carried out simultaneous raids in Glasgow, Wishaw and East Kilbride during which £100,000 of allegedly pirated software, both business and leisure, was seized.

Bob Hay of FAST claimed: 'Piracy in Scotland has been of concern for some time but with some very good information and assistance from Electronic Arts the Strathclyde police carried through a very thorough

investigation. Results so far are most encouraging'.

Bob Hay, FAST ☎ 01-430 2408.

Coming soon to a warehouse near you...



All-ways interface

Micro Control Systems announce a new device which could make interfacing computer equipment much easier. **Plug-a-Buffer** is a power supply with base unit and sockets for input and output. Various modules can be plugged in – RS232, parallel (Centronics) and IEEE-488. Once configuration is sorted out, the transfer of data from one form to another is automatic.

Of course if you're pumping information at 19,200 bits per second the device on the other end can't keep up. So an internal buffer, varying in size from 8K of memory up to 512K, is fitted to the device.

Price for the basic unit with no interface modules or memory is £75. The top of the range 512K version would set you back £229. As for the communications modules, parallel is £18, the RS232 slightly more expensive at £20 and the IEEE (beloved of engineers and scientists) £58.

For more information: Dr Richard Tavener, Micro Control Systems, ☎ 0602 391204. Price enquiries: Chris Wilson, Harvard Marketing, ☎ 01 759 0005.

Club spot

● Our request in *Reaction* (AA35) for details of user groups and regular Amstrad magazines was responded to rapidly by **The United Amstrad User Group**, which offers a bi-monthly magazine; a computer book library; a Public Domain software library; software/hardware discount agreements, and comprehensive help, advice and support. Annual membership costs just £5 a year (how do they do it?).

The bi-monthly magazine, **CPC User**, is hardly the glossiest around, but for value for money and sheer friendliness it's hard to beat. One recent issue carried articles on adventuring and disk operating system compatibility, as well as reviews (*Pyroword*, *DLAN*), a mailbox section, book and PD library updates and a sales and wanted section (advertising free to members).

Furthermore UAUG are positively desperate for advertisers and people to contribute to, and edit parts of, their magazine. So CPC enthusiasts and budding journalists: jump to it!

UAUG are at 1 Magnolia Close, Fareham, Hants, PO14 1PX.

● Bridge enthusiasts will be

delighted to know that there is an unofficial **Amstrad Bridge Club**. It boasts 40 buffs of the card-playing variety united by one single interest: using the CPC to score events and ease the administrative burden.

The software has been developed by amateurs and is available free to anyone. Get in touch with **F.B. Brighton**, who seems a thoroughly decent sort (i.e. he said some v. nice things about AA!), at 30 Ranmoor View, 410 Fulwood Rd, Sheffield S10 3GG ☎ 0742 307555. Interesting bulletin board... ☎ 0905 52536 (BBS); 0905 53248 (voice)

● **Club 464**: Neil, 102 Evelyn Road, Dunstable, Beds, LU5 4NQ. Membership: free.

● Finally in this first *Club Spot*, it would be unfair not to mention **WACCI**. Annual subscription to their monthly wacky 'truly alternative' fanzine is £12. This has to be the weirdest publication that has passed the AA desk, and deserves your earnest attention. **Wacci**, 59 The Green, Twickenham, Middlesex TW2 5BU ☎ 01 898 1090.

Club Spot: AA, 4 Queen St, Bath, Avon BA1 1EJ.

DARK SIDE competition winners

Well done Paul Sawyer of Barry, South Glamorgan, who reckons that the worst sequel of all time is *Rambo XXIV - Let's Kill Everyone We Haven't Killed Already (Simulator)*; and Michael Gledhill of Tavistock, Devon who rates *Dark Side* itself because, 'For Realism, Everything Else Seems Chronic Against Perspective Entertainment'. The rest of you can perhaps take some consolation from the fact that this was Michael's thirteenth AA competition entry, and from the fact that there are some 70 or so prizes to be won this issue!

While we're on the subject of Freescape, the 3D system employed by Incentive on the phenomenally successful *Dark Side* and its predecessor *Driller* (the editor's favourite), details are beginning to emerge of the third game to employ the system. It's called *Total Eclipse*, it's set in Egypt and according to Ian Andrew we're promised 'wierd hieroglyphics, giant pyramids and a strange curse' (what, the return of *Psycho Pigs?*) under an ever-darkening sky. The finished product is unveiled - or at least demo'd - at the PC Show.

Day in the life returns

One section of AA that always generated interest was *A Day in the Life*, and we've had many letters wondering whatever happened to it. Well, it's back - and that's where you come in!

For the benefit of new or amnesiac readers, 'A Day in the Life' was a series of articles written by readers who use their CPC in serious - or bizarre - ways. President Reagan uses one to index his one-liners (but he's real tired right now and so can't write); President Gorbachev uses it

to work out his reforms, but he's kind of busy too...

But what about you? What we're after is about 400-700 of your own well chosen - and it doesn't have to follow the daily diary style. Write to *Day in the Life*, **Amstrad Action**, 4 Queen St, Bath, Avon BA1 1EJ.

Naturally we pay substantially for any contributions we use.

We prefer both a print-out and a disk file, but we'd stretch a point if you ask nicely.

Budget releases

Silverbird, Telecomsoft's budget label, have just signed games from the back catalogues of **Mirrorsoft**, **Palace** and **Digital Integration**. The games, at £1.99 on cassette, are set to appear within the next six months. The **Mirrorsoft** games are *Biggies*, *Dynamite Dan*, *Dynamite Dan II* and *Sai Combat* while the **Palace** titles are *Cauldron*, *Cauldron II* and *Antirad*. **Digital Integration's** contributions are *Fighter Pilot* and *Night Gunner*.

Kixx is a new budget label whose philosophy (it says here) is 'quality not quantity'. Their first two titles, out now, are re-releases of *Gauntlet* and *Metrocross*. Both cost £2.99 on cassette. Future re-releases include *Ace of Aces*, *World Games* and *10th Frame*. Some originals are also due, starting with *Blackbeard* in October.

/packs/

Players have games coming soon: *Joe Blade II*, *Thing* and *Powerplay*, a re-



● Joe Blade is back

release of **Arcana's** trivia game. The other two are similar in style to *Joe Blade* - not surprising, since they're by the same author. All three cost £1.99 on cassette.



● Powerplay returns on budget

Blue Ribbon have signed a licensing deal with **Bubble Bus** to re-release their old titles. *Wizard's Lair*, *Deathville* and *Paladin* are all £1.99 on cassette. **Zeppelin Games** have just released another game for the CPC, *2088*. It's on their blue label: £1.99 on tape. And finally *Battle Valley* from **Hewson** on their **Rack It** label should be out now at £2.99 on cassette.

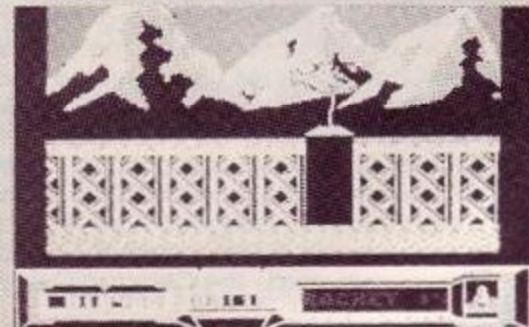

● Tank combat in Battle Valley

Cheetah



Probably the best Joysticks in the world

STARFIGHTER

- ⊗ EIGHT HIGHLY SENSITIVE LIGHT TOUCH MICROSWITCHES
- ⊗ UNIQUE ERGONOMICALLY DESIGNED CONTROL HANDLE
- ⊗ BUILT IN AUTO FIRE
- ⊗ INDESTRUCTIBLE METAL SHAFT
- ⊗ SELECTOR CONNECTOR
- ⊗ FOUR FIRE BUTTONS _____ **£14.95**

MACH 1 ▶

- ⊗ SIX HIGHLY SENSITIVE LIGHT TOUCH MICROSWITCHES
- ⊗ ERGONOMICALLY DESIGNED CONTROL HANDLE
- ⊗ BUILT IN AUTO FIRE
- ⊗ INDESTRUCTIBLE METAL SHAFT
- ⊗ FOUR FIRE BUTTONS _____ **£10.95**

125 SPECIAL ▶

- ⊗ FOUR INDEPENDENTLY CONTROLLABLE FIRE BUTTONS
- ⊗ UNIQUE ROTATE FUNCTION
- ⊗ ERGONOMICALLY DESIGNED CONTROL HANDLE
- ⊗ BUILT IN AUTO FIRE
- ⊗ MOST INNOVATIVE DEVELOPMENT EVER IN JOYSTICK TECHNOLOGY
- ⊗ ALSO FUNCTIONS AS STANDARD TYPE JOYSTICK
- ⊗ SPECIAL FUNCTION REQUIRES DUAL JOYSTICK PORTS _____ **£12.99**

125+

- ⊗ THE UK'S TOP SELLING JOYSTICK
- ⊗ FOUR HIGHLY SENSITIVE FIRE BUTTONS
- ⊗ ERGONOMICALLY DESIGNED CONTROL HANDLE
- ⊗ BUILT IN AUTO FIRE
- ⊗ SELECTOR CONNECTOR _____ **£8.95**

CHALLENGER ▶

- ⊗ TWO HIGHLY SENSITIVE FIRE BUTTONS
- ⊗ ERGONOMICALLY DESIGNED CONTROL HANDLE _____ **£4.95**

In addition to all of the above, all Cheetah joysticks also incorporate the following unbeatable features: ● 12 month warranty ● Automatic centering ● High impact robust body ● Heavy duty base with strong stabilising suction cups ● Eight directional control, designed for use for on table or in hand operation.

Joysticks with built in selector connectors will connect straight into Sinclair Spectrum +2, +3, allowing the user to play Sinclair/Interface 2 compatible games without the use of an additional interface. These joysticks will also control all other games with the use of an interface as per the instructions within the software.

All joysticks in the Cheetah range (including the above) are compatible with the following: Sinclair ZX Spectrum 16k/48k/128k (joystick interface sold separately); Commodore C64 - Amiga - Vic 20 - Commodore C16 & Plus 4 (adaptor sold separately) - Amstrad CPC range - Atari Home computers - Atari 2600 & 5200 Video Game Machines - Sears Arcade Games - Amstrad PC (Subject to software compatibility) Cheetah also manufacture the number 1 joystick for PC's. The PC Powerplay is compatible with the IBM range of PC's, the Amstrad PC 1512 and other PC compatibles when playing games written in analogue style format. It's features include ● Slim ergonomically designed base ● Dual axis sensitivity controls ● Three light touch fire buttons ● Automatic return to centre ● High quality potentiometers ● Metal shaft ● Eight directional control ● 360° cursor control ● 12 month warranty **only £24.95**. An analogue joystick requires a games card - the Cheetah Dual Port Joystick Interface Adaptor Card acts as the interface between the computer and the games card at **only £24.95**.

Prices include VAT, postage and packing. Delivery normally 14 days. Export orders at no extra cost. Dealer enquiries welcome. Cheetah products are available from high street shops and all good computer shops. Please state computer when ordering. Application for FREE membership to Cheetah Exclusive Club with every purchase. Specification and prices are subject to change without notice.

Cheetah



CHEETAH MARKETING LTD
Norbury House, Norbury Road,
Fairwater, Cardiff CF5 3AS. U.K.
Telephone: Cardiff (0222) 555525
Telex: 497455 Fax: (0222) 555527

BAR CPM

First Steps – part two with Richard Monteiro

Welcome to the AA third birthday number (if you think 36 should have been the birthday issue, think again and then explain why the 21st century begins in 2001: besides, last issue was 35 mark two!). Three years on and we still haven't run out of steam. To celebrate we have a bumper-sized *Bar CPM* containing the second instalment of our *First Steps* series and (below) a review of Graduate's updated ROM-based CPM+ system.

We saw last month how CPM's DIR command displays the names of files on disk. It also shows the attributes associated with files. Attributes determine whether a file is read-only or read and

write. Hidden files exist which obviously don't show when DIR is issued. (CPM Plus users can enter DIRSYS to display these files. CPM 2.2 users are stuck unless they use STAT (more on this later).)

Advanced DIR

An advanced version of the CPM Plus DIR command exists: the syntax is `DIR [option,option...]`:

It sits on the system disk and allows files to be displayed in a number of ways. Listing options follow the command and are contained within square brackets. Options can be used individually or strung together when separated by com-

mas or spaces. Options can be abbreviated to two or even one character if the abbreviation unambiguously identifies the option.

So if you wished to display the file size of all hidden COM files in users areas 0 to 3 in drive B:

`DIR B: [SIZE, SYS, USER=(0,1,2,3)] *.COM`
(blimey! – ed.). That's an extreme example, but demonstrates DIR's flexibility and power.

Beyond DIR

CPM doesn't end at DIR, however. There are a handful of other in-built commands that generally keep disks in check. For instance `TYPE` filename displays the contents of the specified file on screen. It is used for viewing ASCII files. CPM Plus users have the option of adding `PAGE` to the command – `TYPE filename PAGE` – which stops the listing automatically after so many lines of text. This allows you to read the text and then press any key to continue.

`TYPE` can be frustrating for 2.2 users if they are not aware of a few key sequences to pause the listing before it scrolls out of view:

Control-S pauses the display.

Control-Q resumes the listing.

Control-C quits from the listing.

The term **Control-S**, for instance, means press the Control and S keys simultaneously.

To send a file to printer, press **Control-P** before issuing the `TYPE` command. Press **Control-P** a second time to stop output to the printer. Note that **Control-P** can be used at any time – before cataloguing a disk, running an application or copying files. Its main purpose is to record what goes on during a work session. Remember everything you type in will be sent to the printer.

Next month we discover more CPM commands and keyboard tricks.

Option

Function

ATT	Displays attributes.
DATE	Shows files with date and time stamp.
DIR	Exhibits files with DIR attributes.
DRIVE	=ALL parades files on all drives.
DRIVE	=(A,B) manifests files on specified drives.
EXCLUDE	Exposes unspecified files.
FULL	Renders all file information.
MESSAGE	Proclaims the names of specified drives.
NOSORT	Unfolds files in any order from disk.
RO	Brings to view all read-only files.
RW	Announces read/write files.
SIZE	Reveals file size in kilobytes.
SYS	Unveils hidden files.
USER	=ALL discloses all files in all user areas.
USER	=(0,1,2) unfurls files in given users areas.

CPM Plus V2 on ROM

Graduate Software ● £32.50
6128 or expanded 464/664

Placing the CPM+ operating system on rom is no small feat: adding to CPM's core commands is even more impressive. Yet Derby-dwellers Graduate managed this back in April (reviewed AA32). At the time we hailed its appearance as the best thing that could happen to CPM, and couldn't imagine anything bettering it. Only Graduate's strive for perfection has resulted in CPM Plus version 2 on ROM. It's here and it's hot.

So what does all this 'CPM Plus on ROM' business entail anyway? Well, for a start you need a romboard. The best – but also the most expensive (£34.95) – comes from the stables of **Rombo Productions** (☎ 0506 39046). Not surprisingly this board is called Rombo. Doubtless you'll be able to pick up other boards for around £15 if you look. Romboards accept 8k and 16k eproms –

these are 28-legged chips – which act like read-only memory. So plugging in the two roms that Graduate's modified CPM comes on gives you instantaneous access to DR's operating system. 464 and 664 users can upgrade to 6128's by following the upgrade article in AA30.

You know if the roms are installed correctly, because a message proclaiming your name appears – very prestigious. Several external (or bar) commands are introduced to the system:

`|CPMVER` displays text reminding you that CPM Plus is Amstrad's and Digital Research's copyright. Version number and serial number are also displayed.

`|NAME` prints your name – just in case you missed it when you switched on your CPC.

`|NOCPM` disables the CPM roms.

`|O` or `|EMS` (not Early Morning Sickness, but close: Early Morning Start) powers up CPM Plus. A string parameter may follow which enables you to boot an application or execute a CPM command automatically. For instance, `|O,"DISCKIT3"` would

start CPM and execute Disckit (assuming, of course, you have a disk in the drive containing a copy of Disckit).

|OHELP lists accessory roms. More on these elsewhere.

|COP allows you to conditionally enter CPM. Inserting a disk displays all executable COM files; selecting one of these causes CPM to start along with the chosen program.

CPM extensions

Like BASIC, CPM has several in-built commands for cataloguing the disk, erasing files and so on (**DIR**, **TYPE**, **USER** etc.). Graduate have somehow managed to add to the command range and even improve existing instructions. **BORDER**, for example, lets you change the border colour. Similarly **INK**, **PAPER**, **MODE** and **PEN** change other screen colour characteristics.

Additions to version 1.71

New external commands include **INOCPM** for disabling CPM on ROM and **IOHELP** for listing accessory roms.

The CPM command set now has **SHOW** (displays information on disk drives attached to the computer), **DATE** (for viewing system date and time), **DATE SET** (for altering date and time), **KDS** (activates an 8-bit printer port if attached), **ROMCAT** (lists all accessory roms) and **SIGNON** (for initialising accessory ROMS).

Standard CPM uses spaces as delimiters between commands - for instance, **DIR *.COM**. The ROM'd version accepts commas as the delimiters: **DIR,*.COM, MODE,2** and so on. Like Basic, Graduate's CPM commands can be chained together. CPM requires each instruction to be separated by an exclamation mark (**MODE 2!DIR *.COM**, say), BASIC uses the colon (**MODE 2:|DIR, "*.COM"**).

Many of the commands added to CPM are similar in name and operation to BASIC's offerings. For instance **CAT** catalogues the disk, **BORDER** changes the border colour, **CLS** clears the screen and **MODE** alters the resolution.

Accessory ROM's

Not only can CPM be placed on ROM: so too can your favourite CPM application or utility. Result: instant CPM programs. The drawback, of course, is that extra ROM slots are occupied. It would be all too easy to fill a romboard with CPM Plus and several accessory ROM's - no bad thing considering how well everything works. The accessory ROM sent for review contained the public domain file manager **NSWEEP** and an unusual command for running Amsdos binary programs. When complete, the accessory ROM should hold an extra two utilities: a formatter and a PCW disk reader.

You can catalogue accessory ROM's in much the same way as a disk, and run files in a like manner. The advantage is speed: one moment you're typing the program name, the next you're staring at the application.

Graduate charge £15 to place CPM programs of your choice on ROM. Contact them on ☎ 0332 702993 for details.

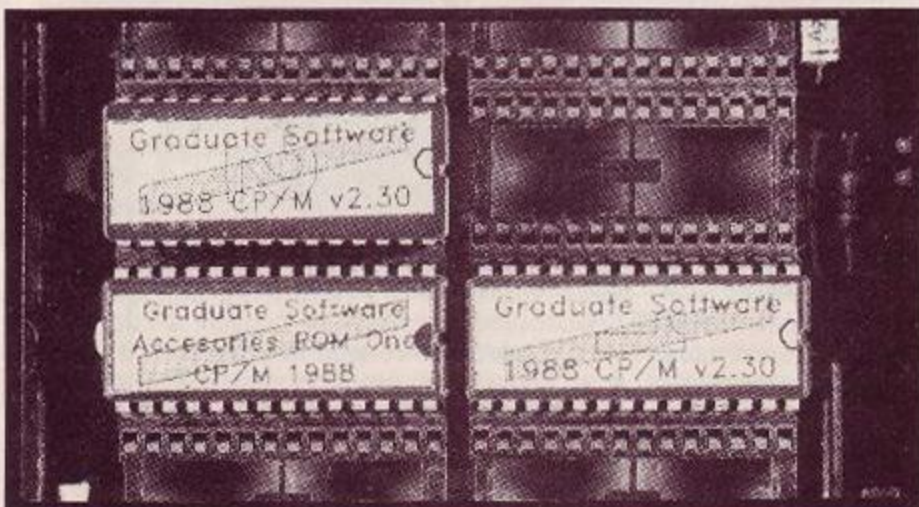

● CPM Plus initialised from ROM. But who's this Review Only chap Graduate keep referring to?



WIN FREE GRADUATE GOODIES!

Are we mad? Are Graduate mad? Graduate, nice chaps that they are, have decided to give away a fabulous copy of CPM on ROM and 10 vouchers worth £5 off any of their product to AA readers. That means you!

All you have to do is scribble your name on the back of an envelope of postcard and address it to *Richard Monteiro's Bar CPM on ROM, Amstrad Action, 4 Queen Street, Bath, BA1 1EJ*. Sometime next month Steve will dip his greasy paw into Pat's even greasier competition sack and pull out the lucky winners' entries.

Other commands actually replace transient programs found on the system disk: **LANGUAGE** changes the character set, **PALETTE** assigns colours to ink pots, **SETLST** sends commands to the printer. If you calculate the total amount of disk space saved by having these extra commands available from CPM, it comes to over 70K.

So what's it like in operation? Remarkable. It's so fast and friendly that you have a hard job believing you're working under the CPM operating system at all. No software we tested complained about the modified system. CPM doesn't have to be tortuous.

Go on, treat yourself.

Legal ROM's

Send graduate your original CPM Plus system disk along with £32.50 and they give you two ROM's in exchange. So why your original disk? Simply to protect yourself and Graduate. The ROM's you receive have the serial number of your system disk, together with your name and address, included in the ROM code (these details appear when you switch the computer on).

This way you won't feel too happy about handing out copies. Similarly Graduate can claim that they aren't actually selling copies of CPM Plus on ROM: rather they are providing a service to transfer your disk-based CPM system onto ROM.

Graduate Software ☎ 0332 702993
14 Forester Avenue, Weston on Trent, Derbyshire

GOOD NEWS

- CPM available immediately.
- Extra instructions added to system.
- Compatible with all CPM software.

BAD NEWS

- Price is up.

PD news

Fareham-based UAUG (the United Amstrad User Group) have just announced a doubling in size of their CPC public domain library.

The library now contains over four megabytes of program with new product in the pipeline.

UAUG publishes a bi-monthly magazine containing all things CPC and provides free access to their PD library, crammed with CPM goodies, for £5 per year.

For further information write to UAUG, 1 Magnolia Close,

Fareham, Hants, PO14 1PX or Gary Carter ☎ 0329 281324.

COS PD

Clockwork Orange Software - nice name! - (COS) of Runcorn, Cheshire, have just started up a PD library, containing both CPM and Amsdos software.

Membership to the club is free while the copying fee is £3.60 - far cheaper than many existing PD clubs.

Information: Clockwork Orange Software, 11 Stanley Villas, Greenway Rd, Runcorn, Cheshire, WA7 4NW.

When you buy a whole new Amstrad system, why use only half of it's potential?

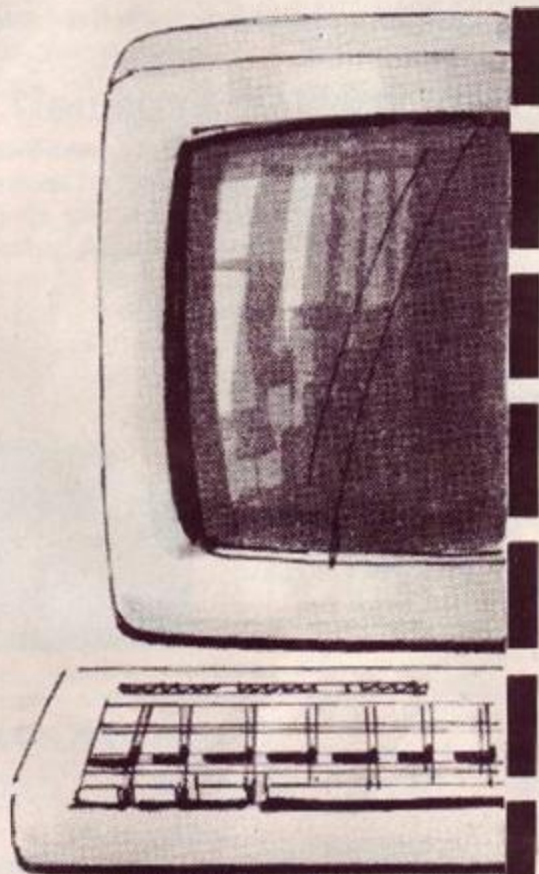

1. 12 Issues of the Official Amstrad Magazine.
2. FREE access to our superb CPC Technical Support Service.
3. Discounted Software . . . best prices in the U.K!
4. Monthly Amdata CPC Newsletter.
5. 24hr Ordering Service.
6. Welcome Pack.
7. Introductory Gift if you join TODAY! (worth between £3 - £7)

A Message from Amstrad's Chairman

Dear Amstrad Computer User,
 You don't need me to remind you that you have selected the best computer in it's price range. Numerous journalists from the specialist press have now contributed to the opinion that Amstrad computers represent the best all-round machine you can buy.
 One of the many reasons why computer journalists have received our products so enthusiastically is undoubtedly our careful attention to providing information on the system and it's software.
 You can be a part of Amstrad's ongoing effort to inform and help users by taking advantage of this opportunity

to join the User Club. Catering only for the Amstrad computer user, this specialist support club was initially formed by Amstrad solely for the purpose of assisting you with all your computer needs.

There are many immediate and direct benefits available, so don't delay before filling out the application form below and sending it back to Amsoft.

Yours sincerely,

Alan Sugar
 Alan Sugar
 Chairman AMSTRAD Plc



THE OFFICIAL AMSTRAD USER CLUB & AMSOFT MAIL ORDER, ENTERPRISE HOUSE, PO BOX 10, ROPER STREET, PALLION INDUSTRIAL ESTATE, SUNDERLAND SR4 6SN TEL. 10911 510 8787

▲ HOW TO JOIN THE CLUB ▲
 Simply fill in the coupon and return it to us at the address shown together with your remittance. We'll send you your exclusive membership discount card, a 'Welcome Pack' and your FREE Introductory Gift.

FOR OFFICE USE ONLY

Yes I want to enjoy the benefits of Amstrad User Club Membership - Please enrol me today.
 I enclose cheque/P.O. for £24.95 payable to AMSOFT MAIL ORDER or debit my credit card

ACCESS/ VISA M/C D/C A/C

Expiry Date /

My machine model is:

Name:

Address:

Postcode: Day Phone Number:

All offers subject to availability; all prices correct at time of going to press

AA/KP10

POST TO
OFFICIAL AMSTRAD USER CLUB
 ENTERPRISE HOUSE, PO BOX 10, ROPER STREET
 PALLION INDUSTRIAL ESTATE, SUNDERLAND SR4 6SN
 or Ring (091) 510 8787 NOW!



THE AA COVE



Dizzy, AA Special Edition

Those wonderful people **Phillip and Andrew Oliver** (we interviewed them last month – you surely haven't forgotten already?) have been working round the clock to bring you a novel variation on a classic game.

For the benefit of those of you who never got acquainted with this hilarious classic, here's an introduction.

that enables you to complete the game. Make the potion and the quest is complete.

How special is special?

'Special', we hear you ask. 'How special is special?' Well, rather than changing a few rooms around, altering a few puzzles and the odd sprite, the Oliver twins have spent a great deal of time and effort adding various messages and even some extra graphics.

There can be little doubt that this edition, **unique** to AA, offers even more incentive for you to complete what was already a hugely enjoyable game. Hope you enjoy it as much as we do (haven't laughed so much since Pat tried to mend our 464).



The Hero

You play **Dizzy**, a charming rotund creature reminiscent of Humpty Dumpty. A guy with guts, intelligence and a strange penchant for picking up and dropping objects.

The Villain

Your adversary is **Zax**, a really devious opponent. He's an evil sorcerer. How evil? Well, he'd conjure up rain on a Sunday afternoon to spoil the cricket.

The Quest

Dealing with Zax won't be at all easy though. Forget all your conventional weapons – blades, firearms, bombs etc. The spell caster can't be defeated without the 'Avawiffovee' magical potion which you have to brew. (Footnote: the potion has the side effect of curing athlete's foot, although personally I reckon that's just an old wives' tale.)

It's not any old potion. Scattered throughout the screens that comprise *Dizzy's* world are various components of the ultimate weapon



Control Keys

Keys	Joystick	Action
SPACE	Fire	Start game
Z	Left	Left
X	Right	Right
SPACE	Up	Jump
ENTER	Fire	Pick up/ Drop/Use

Micro Assembler

Desmond Daly, Glounthane, Co. Cork, Eire

Programmed in Basic, 'Micro' lets you enter assembly listings into the computer. These listings are directly replaceable for **machine code**, the language the Z80 chip in the Amstrad understands.

If you've been following *First Bytes*, our machine code course, you may appreciate just how frustrating assembling code by hand can be.

This program takes some of the sting out of using the language – although that's not to say that learning machine code becomes much easier!

For more on the use of the assembler see *First Bytes* in this issue.

```

Assembling to 4ME28
;some code taken from BUCKERS ONLY col
which prints the accumulator as a
; 3 digit decimal number
; set base
ld d,00h
cal -print
ld d,01h
cal -print
ld d,02h
cal -print
ld d,03h
print ld d,0
;loop sub 1
jr c,finish
inc d
jr -1loop
finish add a,d
push af
ld a,c
add a,b
call -exit
  
```

Special Disk Formatter

Tan Kwong Peng, Singapore

Ever had a disk with a bad sector or two on it? It's a real pain, because even if you've backed up the contents you still can't use the bad disk.

Until now, that is. This program is not only a formatter for data disks – it can **recover corrupted disks!**

The program loads in two halves, Basic and machine code. You are then prompted for the drive to be formatted, and the program waits politely until you are ready.

The program then starts

work using the data format. Just suppose it finds a bad sector: it then assigns that sector to a dummy file called **CORRUPTED**, so that the rest of the disk ignores the sector. Make sure that you don't accidentally erase this file!

If the program can't cope with the damaged disk it recommends **vendor format**, because bad sectors sometimes occur in the directory area, and such sectors can't be assigned to a dummy file. But this should be rare.

R CASSETTE

Smart II

Robert Buckley, London

This art package appeared in *Type-Ins* in AA29, and all this time later we're still getting letters asking for more of the same. So **Smart** has now been upgraded. And we think you'll agree that for a program written mostly in Basic, it's pretty impressive.

For one thing, virtually all controls are carried out with a joystick (it's a joystick only program). For another, it works with all CPC's, on disk and tape. It uses pull down menus to select features, and these cover the art area, which is put back as it was before the menus appear.

Joystick movement is 'intelligent': the pointer starts moving slowly, but accelerates the longer you keep going in a given direction. So control is fast and accurate.

Smart II is fairly conventional. First come the **line drawing commands**, which produce outlines on the screen. These are **draw** (allows freehand drawing and single pixel selection), **line**, **box**, **circle** (can handle ellipses), **shape** (draw any polygon) and **spray can**.

Selecting which of the 16 inks to use is very simple. Using the palette option, the inks can all be selected at the touch of a button. Changing the actual pen colour is accomplished in a similar manner. And there's two line thicknesses.

Mistakes can be reset to the paper colour - in effect, erased. This is a bit too hefty for fine alterations, so a zoom function is available under **edit**.

Block operations are here - **reflection in the x and y axes**, and **copy**. The size of the area to be copied is under your control: but remember, the larger the area the longer it takes.

Loading and saving are available, and the computer can **wipe** the screen clear if you've really messed up.

You've seen Pat's not-very-impressive attempt (right): now it's your turn! We want your own work, using **Smart II**, on disk or tape. Send it today to: *The Look*, AA, 4 Queen St, Bath, Avon BA1 1EJ. (Plaster everything with your name and address: we can't be responsible for anything not so marked.)

Tape to disk? No worries!

Dizzy - The Special Edition is a cinch to put on disk. Simply press the **s** key just before the game finishes loading, and it automatically saves a copy onto disk! Around 61K should be enough.

To help you to get the utilities onto disk, we (well, Gary really) has put a program onto the end of the tape. All you have to do is type **RUN"ONDISK.BIN** (press play on the tape until it has loaded, and then rewind and replay the tape). The program now automatically loads all the utilities and help files, and saves them onto disk. On this side about 38K of disk space should suffice.

It's free - but is it any good?

Surely this here art designer can't be much good? You'd be surprised - Pat McDonald finds a suitable case for treatment

Let's **get down and draw** something. (You may think this is a **waste of time**, but what if we tell you that you could win £20 and get it into *The Look's* art gallery?)

- Begin by drawing the **outline**. What you're looking for is the boundaries between sharply contrasting areas of colour. The raw drawing commands are very good at this, with the **circle** command especially useful for ellipses and partial curves. As this is a desert landscape, let's put a pyramid in. Other features are a lake, road and a helicopter. (The helicopter is an excuse for the perspective, which places the viewer hundreds of feet in the air.)

- This next bit, **cleaning up**, is fiddly. You have to take all the superfluous edges and lines on the screen and get rid of them. Either use the erase function (fast but clumsy) or edit (slow but sure).

Once you finish this - and it's worthwhile spending time getting it just right - you can block-fill the major areas of colour. Filling the pyramid shadow, the sun and the dark sand takes time, and it's a good idea to make periodic saves, just in case the **fill** command goes manic.

- Now we reach the **fun bit**, where we embellish the partially completed screen. The **spray can** comes into its own at this stage, and the free hand drawing/dot function and zoom function help considerably.

The helicopter and lake are good examples of small detail. Both were drawn roughly, then finished with the zoom/edit option. Notice the black dot near the sun? That was a mistake I decided to leave in - it gives the impression of a high flying bird. (*Oh so that's what it is - ed.*)

- So now you have a finished picture. Or do you? This stage can be the most frustrating, because as a rule a picture is most vulner-

able just prior to completion. Lots of saves and loads are a good idea. The tricky parts are deciding on the location of highlights and shadows (especially on rounded or irregular shapes) and similar tiny details - I find it's difficult getting the grip right on a hand.

Getting the job done was a bit of a pig, because of the shadow on the pyramid which bisected the road, and meant the road was two different colours. Time to reach for the **spray can** and **freehand** options again.



● Finished! I'll start the bidding at £50,000... Do I hear £60,000? (*no - ed.*)



● So far, not much



● Filled, but still crude



● A big improvement

AA is three: help us celebrate!

- dozens of prizes to be won!



CAN it really be three whole years since AA began? Hard to believe, we know, but it's true - we checked. So we thought we'd invite you - without whom, after all, none of this would have been possible - to help us celebrate.

OUR first prize is a heap of hardware that would make your computing life infinitely more exciting:

- A KDS second disk drive (worth £150) that runs 5.25 inch - i.e. cheap - disks;
- A 'Designer' modem package from Modem Marketing that includes a CPC interface and Axis software (you may recall us raving about it in AA33) - worth in total about £175;
- A full year's subscription to Micronet worth £80 (reviewed in AA35);
- And last but not least a full year's subscription to Microlink worth £75.

ALL in all you couldn't buy this little lot for anything under 450 big ones. And pretty soon one of you lucky

people is going to be waking up to one very overloaded postman!

BUT that's not all! We have some rather useful consolation prizes too. KDS (yes, them again) have also put at our disposal:

- A CPC serial interface (retail value £50);
- A Romboard (£25);
- And an 8-bit printer port (£20).
- EVEN Future Publishing have pushed the boat out a bit, offering not one, not ten, not even 20 but 36 - as in 36 issues completed - of the exclusive and as yet otherwise unobtainable Amstrad Action teeshirts. We can't for obvious reasons promise such a garment will look as good as you as it does on the delectable Sharon, but with so many teeshirts on offer your chances of winning have to be pretty good, don't they?

ALL you have to do to win a second disk drive and the modem-plus-trim-mings or one of our dozens of consolation prizes is to answer our Not Completely Serious Quiz. It can't be too difficult, because even the editor managed to answer some of the questions! (I did? - ed.)



SO get cracking why don't you? Put your answers on a postcard or the back of an envelope (NO LETTERS OPENED!) more or less as we've done - but don't put your name as Leopold Bloom (unless it happens to be Leopold Bloom). Indicate whether you'd like a medium or an extra large teeshirt (if in doubt we recommend the extra large).



1. WHICH of the following is a word processor:

- a. Space Invaders
- b. Protext
- c. Advanced Art Studio?

2. WHAT was Mastergame in AA34?

- a. Psycho Pigs UXB
- b. Outrun
- c. Dark Side?

3. DUE to editorial incompetence, which AA never 'appeared'?

- a. AA1
- b. AA999
- c. AA36?

BUT if you think we'd be daft enough to supply you with the correct answers you don't deserve to win anything!

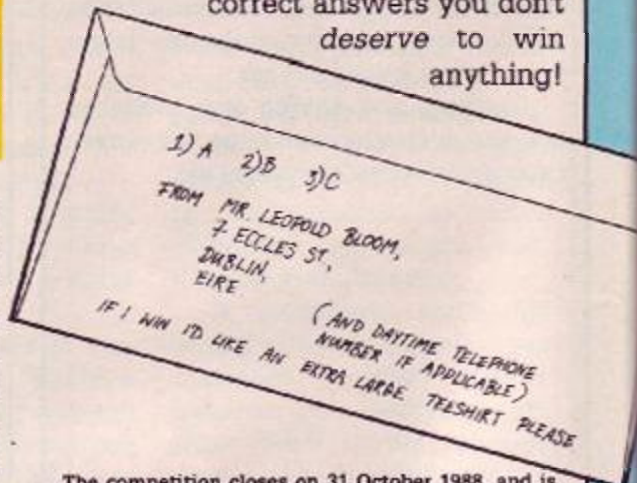

The competition closes on 31 October 1988, and is not open to employees or relatives of Future (sorry mum).

MICRONET (C) 8093005h 0p

Micronet

- 1. Micro magazines
- Today's Update: Atari ST Key 12
- 2. Neostashes
- 3. Meet people
- 4. XTRA Entertainment
- 5. Prestel
- 6. Software for sale
- WHAT'S NEW TODAY? GOTO #
- Full 9-7 Index Key 00

*** NEW-LOOK MICRONET: GOTO 9 ***

Many commands in Basic are controlled by operands – numbers that come after the commands themselves, describing precisely how your CPC performs the tasks it's told to do.

Let's look a little closer at operands. We know already that we can use variables as operands. That's because variables, as we've seen, are words that stand in for numbers. The line

```
a=80:b=120:PLOT a,b
```

means the same as `PLOT 80,120` because `a` stands in for the number 80 and `b` stands in for the number 120.

Remember how we used `PRINT` to display the values of variables? Type in this program:

```
10 a=50
20 PRINT a
30 PRINT a+10
40 b=40:PRINT a+b
```

Now `RUN` it and you get a list of numbers running down the screen. The first of these comes from `PRINT a` in line 20. The number is 50, because that's the value of `a`. The second number, 60, comes from `PRINT a+10` in line 30. Since `a` has a value of 50, `a+10`, naturally enough, has the value of 60 and that's what the `PRINT` command displays.

The other two numbers speak for themselves. Satisfy yourself that you understand why those values are printed, then type this next program in – not forgetting to `NEW` the previous one first.

```
10 a=95:b=140
20 MOVE a,b,1
30 DRAW a,b+80,1
40 DRAW a+50,b+80,1
50 DRAW a+50,b,1
60 DRAW a,b,1
```

When you `RUN` it what happens? That's right, a rectangle. The variables `a` and `b` determine where the rectangle goes on the screen, so you can put it somewhere else just by substituting a

ABSOLUTE BEGINNERS

Get to grips with Basic the easy way

new line. Try it now – just type

```
10 a=470:b=10
```

or something like it. The rectangle is still the same shape, but it's drawn somewhere else altogether.

We've seen variables do this sort of thing before, allowing us to change the effect of a program in some way without having to alter every line of it. Notice how all the `MOVE` and `DRAW` coordinates depend on the values of `a` and `b`. It's fine to use things like `a+50` as the operand of a command: your CPC simply looks up the value of `a`, adds 50 to it, and uses the answer as an operand in the normal way.

More on variables

The whole point of a variable is that you can vary it – change its value, in other words. To do this you use an *assignment*, like `a=40` or `d=571`. So far this is the only kind of assignment we've seen: *variable name=number*.

But there's more to them than that. Instead of a number after the `=` you can use a variable or expression. Try this:

```
10 a=90
20 b=a
30 PRINT b
40 c=b+20
50 PRINT c
```

The assignment in line 10 sets the value of `a` to 90. The assignment in line 20 makes the value of `b` the same as that of `a` – 90, in other words – so that's the value that gets printed out by line 30. Line 40 works in a similar way, making `c` equal to the value of `b` plus 20. You can see it's worked by the value printed in line 50.

That's all very well, but the next section takes assignments a whole lot further. Type and `RUN` this:

```
10 a=55
20 PRINT a
30 a=a+10
40 PRINT a
50 a=a+10
60 PRINT a
```

The assignments in lines 30 and 50 are a little different from what we've seen before. The new value that each of these assignments gives a depends on the value of `a` up to that point. As you can see from the numbers printed out by the program, `a` has a different value at each of lines 20, 40 and 60. Even though the assignments in lines 30 and 50 are identical, they don't give `a` the same value.

Each of the `a=a+10` assignments increases `a` by 10. This is not a proper equation in ordinary maths, but Basic takes `a=a+10` to mean *take the current value of a, add 10 to it and make that the new value of a*. This idea of using the old value of a variable to make its new value can come in very handy indeed.

Loops again

Lets look at a program using this idea. Type and `RUN`:

```
10 a=1
20 FOR b=1 to 20
30 a=a*2
40 PRINT a
50 NEXT b
```

The numbers it prints are powers of 2. Line 30 doubles the value of `a` each time, and line 40 puts the new value on screen. We don't actually use the loop variable `b` in this process. It's just there to make sure the CPC runs through the `FOR-NEXT` loop the right number of times.

Next month we go even loopier, and then consider the `PRINT` command.

Not very much maths at all, honest

When you have something like `a+50` or `a+b-10` we call it an *arithmetical expression*, or just *expression* for short. You've already met expressions in the square-digging program in last month's *Absolute Beginners*.

If you always thought computer programming was all about maths, don't worry. It isn't. A little simple arithmetic can come in handy, but it's hardly terrifying. We've already just seen adding and subtracting in the expressions just given, and they're nothing to be too frightened of, are they?

Multiplying and dividing are almost as simple, apart from one slight snag: where's the keys? Well, instead of `x` for multiply you use `*` and instead of `÷` you use `/` (same key as the question mark). Type this one in and `RUN` it:

```
10 a=20:b=4:c=5
20 PRINT "Multiplication"
30 PRINT a*b
40 PRINT a*c
50 PRINT "Division"
60 PRINT a/b
70 PRINT a/c
```

Notice how your CPC does all the work: it has a kind of built-in calculator (we should be so lucky!) that does your number-crunching for you, so all you've got to do

SIREN SOFTWARE

DISCOLOGY

This program really is the ultimate
in disc utilities.

Just look at these features:-

- Disc copier will backup 99.9% of all Amstrad discs
- Copy multiple files in one go
- Will also transfer files from tape to disc and disc to tape
- Will work with 1 disc drive but if 2 are available, it makes use of both.
- Uses full 128K on a 6128 or 64K on a 464/664. Utilises any memory expansion.
- Edit any sector regardless of format.
- Display sectors in Z80 disassembly, Hex, Ascii, Binary, Octal, Decimal and even as a basi listing!
- Search disc/file for a given string, Dump screen onto a printer.
- Built in calculator for Hex to decimal conversions etc
- Full graphically displayed explorer
- Exceptionally easy to use. Uses pull down windows and menu etc
- Many other unique features.

Available now on disc at **£14.99** CPC 464/664/6128

Masterdisc/Oddjob owners, we will put Discology
on the B side of your disc for only £9.99

DISCOVERY PLUS

★★★ NEW ★★★ DISCOVERY PLUS ★★★ NEW ★★★
UPDATE

The best selling tape to disc transfer program for the AMSTRAD has now
been upgraded to transfer many more programs with a lot less hassle.

- ★ Will transfer programs from all the top software houses. (Ocean, US Gold etc)
- ★ All transfered programs "stand alone" with this new version
- ★ Very easy to use, ideal for the novice user.
- ★ Transfers the majority of Amstrad software from tape to disc. Will cope with normal loaders, headerless loaders, Speedlock and flashloading programs.
- ★ Compatible with the 464/664/6128. Makes use of extra 64k on a 6128.

DISCOVERY PLUS
available now on disc only **£14.99**

Existing owners can upgrade to the new version for only £8.99.
(No need to return original disc.)



SIREN SOFTWARE TEL 061 228 1831
2-4 OXFORD ROAD, MANCHESTER M1 5QA



Unbeatable value

CPC464
CPC664
CPC6128

MONEY MANAGER

SAVE £5 on RRP of £29.95 when you order direct from Connect Systems

ONLY £24.95

Incl. VAT, P&P

Unrivalled features

Money Manager Plus
for PCW 8256, 8512,
9512, PC1512, 1640,

PPC
£39.95
Inc. VAT, P&P

Financial management software for personal and/or small business use

Money Manager is an easy-to-use system for recording all financial transactions, and for analysing them in a number of very powerful ways in order to facilitate sound financial management. It is ideal for controlling the finances of a small business, or for users wishing to control their personal finances in a business-like way. Use it to check bank statements, keep track of expenditure, monitor cash flow, make budgeting forecasts, prepare business financial statements, pacify your bank manager, convince the tax and VAT inspectors, avoid nasty surprises, etc. etc.!

12 months of entries are kept in a file stored on your disc. At any time, you may load a file into the computer memory, add to or edit the entries, analyse them, print statements, and then save the updated file for later use. Entries may be historic (for record keeping) or forecast (for budgeting). You may have any number of separate files, and make copies of files for archive purposes. You may advance the period covered by a file month by month.

Up to 100 separate transactions may be entered per month. Each entry consists of:

- The day of the month, e.g. 23rd of June.
- An account number, one of up to 9 defined by you to suit your circumstances e.g. 1=Barclays, 2=Visa, 3=Halifax etc.
- Reference, e.g. ABC123 for a cheque number or invoice reference.
- A class code, one of up to 50 defined by you to suit your circumstances e.g. h0=Household expenses, h1=Mortgage, h2=Rates or p0=Production, p1=Raw materials, p2=Assembly, p3=Packing, etc.
- A description so that you can see what each transaction was for, e.g. "New gearbox" or "Box of 10 discs."
- An optional single character mark which you may include for further classification, e.g. b=business, p=private, etc.
- The amount of the transaction, which may be plus or minus.
- A marker to indicate whether the entry is exempt, zero rated or taxable for VAT, or alternatively the actual VAT paid.

You may select categories according to account, class and mark (e.g. all entries, or all motoring expenses for business using a credit card, etc.) and produce reports on the screen or printer as follows:

- Full detailed statements, showing each transaction for any month or for the whole year.
- Detailed monthly VAT statement showing input and output amounts excluding VAT, the actual VAT and the total amount, plus totals and net VAT due.
- Tables showing the totals in each class for each month of the year.
- Tables showing the totals in each class for each account.
- Tables showing monthly maximum, minimum, average balances, turnover, cashflow etc.
- Bar graphs of any category month by month.
- Pie charts of annual totals for various categories (CPC version only).

Plus: standing orders—entries optionally sorted into date order—item search facility. Comprehensive manual and full set of practice data included. Full telephone support.

Send cheque or credit card number or phone for immediate despatch

Connect Systems

3 Flanchford Road, London W12 9ND. 01-743 9792 8am-10pm 7 days a week



PROBLEM ATTIC

Can Pat McDonald save the world again? Nope.

Disk drives

In AA30 you published a very interesting step-by-step conversion of a 464 to a 6128. The only problem is the cost of the DDI-1 disk drive, £159.95. Is it possible to make a DDI-1 oneself? I've seen an article showing how to make a second disk drive. Obviously there is some difference, though, with interfacing the disk drive to a 464. Is there any way for an individual to make a DDI-1?

D Harper, Gloucester

It is certainly necessary to have an interface to plug a disk drive into a 464. Such an interface is included in the price of a DDI-1. As for making a replica, well that is possible. You would also have to buy the disk ROM, code AM40015, from CPC though.

Come to think of it, if any hardware people out there have projects for DDI-1 interfaces and memory upgrades, send them in to Soldering On. Who knows, the 464 only syndrome may fade away, with programs developed solely for disk/128K memories.

Bugged until hacked

I have recently bought US Gold's *Killed Until Dead*. After loading the *Hacker* program, I tried running it and got the usual message and a READY message. I tried listing the program, and got 28532 le your school ties

Why?

Benjamin Fall, Fareham

The code in the program probably contains this message. When the operating system regains control, this code is then interpreted as the above Basic snippet.

Dim view

I own a 464 with a colour monitor. Until the monitor gets warmed up - which takes about two hours - everything is dark. Even then you still can't see all the detail. Are all colour monitors like this, or is something wrong with mine?

M Lindley, Dewsbury

Our screenshots are taken on a CTM640. So your monitor is definitely below standard. I hope your machine is still under guarantee: otherwise you'll be paying for a repair job.

Quest for the answer

I noticed this question in *Problem Attic* (AA34) from Daniel Williams from Orpington: 'Can the 40025 ROM chip operate on a ROM board? Well, I have a 6128 and I'm interested in using the 464 ROM (40009) in a similar way on a ROM board (I have a Rombo).

I understand that you can't have two ROM zeroes at the same time, so if I plugged in the 464 ROM into ROM socket zero on the ROM board and attached a

switch to the internal 6128 ROM, could I then choose 464 mode by switching off the 6128 ROM with the switch and turning on the 464 ROM with the dipswitch on the ROM board? Would the 464 ROM initialise?

If that lot sounds OK then:-

- 1) Which leg do I connect the switch to on the internal 6128 ROM?
- 2) How much would a 464 ROM cost me?
- 3) Where do I get it from?

I also have Rodos on ROM but no five-and-a-quarter inch disk drive so:-

- 1) Could you recommend a five-and-a-quarter inch disk drive that offers full capacity under the excellent Rodos operating system? (One that I don't have to do anything to, apart from plugging it in.)

- 2) Could Rodos handle a dual, double sided and double density five-and-a-quarter inch disk drive Cumana drive? I have seen one in a department store for £89, but it has a BBC connector.

N Andrew, Newbury

Return or bust

In AA35 there was a program called *Dart Scoreboard*. When I'd typed in the 1,530 lined program all I got was the prompt Ready.

Kevin Pool, Wembley

I regret that the last program line was missed off the listing. It was:

1540 RETURN

The problem with using a ROM board is that the 40025 is a 32K chip, split into lower and upper halves. This is non-standard, and so you cannot plug the 40025 into a ROM board to start with, or any other operating system ROM.

That said, you can have both the 6128 and 464 (or 664) ROM's available at the flick of a switch. A full project for this has been sent to Soldering on, and should appear before too long. So the long and short of it is:- Pin 28 is used on both devices to enable/disable the chips. A little extra circuitry is required though to ensure that both ROM's cannot be switched on at the same time, which could result in permanent damage.

Also, it would be necessary to reset the entire machine to initialize the ROM. However, the main advantage of such a system is total software compatibility.

The CPC 464 ROM costs £35.92 from CPC Ltd, ☎ 0772 555034, 194-200 North Rd, Preston PR1 1 YP.

Your other points are, I think, best answered by Romantic Robot themselves, who make the *Multiface*. Contact them on ☎ 01 200 8870.

Graphics help

When I type in the *Printer Dump* routine from AA35 I get the message **Syntax Error in 90**. I have typed in the line correctly, so what is wrong? I have a 6128.

M J Foster, Heywood

For an explanation see The Look, our graphics series beginning this month.

Non comprendez

After reading the CPC-CPC link article in AA30 I was confused. Why are connections made to the common pins and ground? What is it that changes the potential of some part of the set-up to necessitate the use of diodes? Is the cause controllable by software?

C Dunn, Doncaster

The diode/ground combination is used simply to ensure that the right information goes to the right joystick port. Certain pin signals are used on both joysticks, and so the diodes stop the signals 'jumping' to the other joystick.

The cause is controllable by software, in the sense that signals are sent to one or other half of the parallel connection.

Stuck?

Write to *Problem Attic*, Amstrad Action, 4 Queen St, Bath, BA1 1EJ.

S.D.C.

309 Goldhawk Road, London W12 8EZ

BUY BY PHONE
RING 01 741 1222 or 01 995 3652 or 0525 371884

PRICE PROMISE

If you wish to purchase any product from our list and find that you can buy the same product cheaper from another mail order company, simply enclose the lower amount, stating the name of the other company and where you saw the advert. (It must be the current issue). Price Promise does not apply to other companies "Special Offers".

ENQUIRIES
01 748 3597

AMSTRAD		RRP	OUR
Outrun	D4	9.99	8.50
Platoon	D3	9.95	6.50
Alternative World Games	D4	9.99	8.50
Winter Olympiad 88		9.95	6.50
Cyberoid	D4	8.95	7.45
Eddie Edwards Super Ski	D3	9.99	6.99
Captain Blood	D3	9.95	6.95
Street Fighter	D4	9.99	8.50
Target Renegade	D3	8.95	6.50
Road Blasters	D4	9.99	8.50
19 Part 1 Boot Camp	D3	9.95	6.95
Buggy Boy	D3	9.95	6.95
Rastan	D3	8.95	6.50
Hunt for Red October	D4	14.95	10.50
World Class Leaderboard	D4	9.99	8.50
Impossible Mission II	D4	9.99	8.50
Gunship	D4	14.95	10.50
Football Director		8.95	6.50
Victory Road	D3	8.95	6.50
The Games Winter Edition	D4	9.99	8.50
Bionic Commandos	D4	9.99	8.50
Karnov	D3	9.99	6.95
Salamander	D3	9.99	6.99
Guild of Thieves 6128 only		19.95	13.99
ATF	D2	8.95	6.50
Last Ninja II	D3	12.99	8.99
Mickey Mouse	D4	9.99	8.50
Infiltrator II	D4	9.99	8.50
Marauder	D4	9.99	8.50
Revenge of Doh	D3	6.95	6.50
Peter Boardwalk's Int Football	D3	6.99	6.50
Jinxer (Disc only)		19.95	13.50
Allen Syndrome	D3	9.95	6.95
Action Force II	D3	9.95	6.95
Dark Side	D3	9.95	6.95
Where Time Stood Still	D3	8.95	6.50
Time & Magik	D3	14.95	10.50
Football Manager II	D3	9.95	5.95
Empire Strikes Back	D3	9.99	6.95
Gold Silver & Bronze	D7	14.99	12.50
Barbarian II	D3	9.95	6.95
Corruption (6128 disk only)		19.95	13.99
Great Giana Sisters	D4	9.95	8.50
Night Raider	D4	9.95	8.50
Whirligig	D3	8.95	6.50
Fire & Forget	D3	9.95	6.95
Gary Linekers Super Skills	D4	9.95	8.50
Hercules	D4	9.99	8.50
Dream Warrior	D4	9.99	8.50
Vindicator	D3	8.95	6.50
Hopping Mad	D3	9.99	6.99
Soldier of Light	D3	8.99	6.50
Beyond The Ice Palace	D3	9.95	6.95
Psycho Pig UXB	D4	9.99	8.50
Daley Thomasons Olympic Chall	D2	9.95	6.95
Fernandez Must Die	D3	9.99	6.99
Bombboozal	D2	9.99	6.99
Bushido	D4	9.99	8.50
Football Director II	D5	19.99	13.99
Pro BMX		4.99	3.99
Overlander	D3	9.99	6.99
Heros of The Lance	D4	9.99	8.50
1943 The Battle of Midway	D4	9.99	8.50
Typhoon	D3	8.95	6.50
GI Hero	D3	8.95	6.50
Netherworld	D4	9.99	8.50
Double Dragon	D3	8.99	6.50
Operation Wolf	D3	8.95	6.50
Virus	D3	8.95	6.50
Gary Linekers Hot Shots	D4	9.99	8.50
Power Pyramids	D3	9.95	6.95
T-Wrecks	D4	9.99	8.50

COMPHITS VOL 4
Only £7.25
Dandy, Spindizzy, Starquake
Brides of Frankenstein
Sacred Armour of Antrilad
Uchi Mata, Deactivators
Classic Snooker, Magic
Madness, Alloykat, Iridis Alpha
Skate Rock

SOLID GOLD ONLY £8.50
DISC £12.50
Gauntlet
Ace of Aces
Leaderboard
Winter Games
Infiltrator

GAME SET AND MATCH ONLY £8.99 (DISC £13.99)
Featuring: Basketball, Soccer, Vault, Swimming, Shooting, Archery, Triple Jump, Weightlifting, Ping Pong, Pistol Shooting, Cycling, Springboard Diving, Giant Slalom, Rowing, Penalties, Ski Jump, Tug of War, Tennis, Baseball, Boxing, Squash Snooker/Pool.

LEADERBOARD PAR 3
ONLY £12.50
DISC £16.50
Leaderboard, Leaderboard
Tournament, World Class
Leaderboard

6 PACK VOL 3
ONLY £7.25 DISC £10.50
Ghost Goblins
Paperboy
Enduro Racer
Dragons Lair
Living Daylights

BEST OF ELITE VOL 1
ONLY £3.99
Bomb Jack
F Bruno's Boxing
Commando
Airwolf

BEST OF ELITE VOL 2
ONLY £8.99
Paperboy
Ghost 'n Goblins
Space Harrier
Bombjack II

5 COMPUTER HITS
ONLY £3.99
Wizards Lair
Zizad
Contraption
Kettle
Attack of the Killer Tomatoes

KONAMI ARCADE COLLECTION
Only £7.25 Disc £13.50
Mikie, Jackal, Nemesis,
Jailbreak, Ping Pong,
Yie Ar Kung Fu 2, Hypersports,
Shao Lins Road, Green Beret,
Yie Ar Kung Fu

MAGNIFICENT 7
ONLY £7.45 DISC £13.95
Head Over Heels
Cobra & Arkanoid
Short Circuit & Wizball
Frankie Goes to Hollywood
Great Escape & Yie Ar Kung Fu

TOP 10 COLLECTION
ONLY £6.99, DISC £9.99
Saboteur, Saboteur II, Sigma
7, Critical Mass, Airwolf, Deep
Strike, Combat Hints, Turbo
Esprit, Chanatos, Bombjack II.

10 GREAT GAMES 2
ONLY £8.50
Mask, Death Wish 3, Jack the
Nipper II, Thing Bounces Back
Basil Mouse Detective, Convoy
& Rector, Samurai Trilogy,
Duct Matrix

KARATE ACE
ONLY £10.50
DISC £12.50
Way of The Exploding Fist,
Kung Fu Master, Bruce Lee,
Avenger, Way of the Tiger,
Uchi Mata, Samurai Trilogy

WE ARE THE CHAMPIONS
ONLY £7.25, DISC £13.50
Renegade, Rampage,
Supersprint, IK+, Barbarian

HEWSON'S SMASH HITS
ONLY £8.50 DISC £12.50
Exolon
Zynaps
Ranarama
Uridium Plus

SPECIAL OFFERS		RRP	OUR
Strike Force Cobra		9.95	1.75
Nemesis The Final		8.95	1.99
Colour of Magic		8.95	1.75
Rogue Trooper		8.95	1.75
Dragons Lair		8.95	2.99
Enlightenment (Druid II)		9.99	2.99
Elevator Action		9.95	2.99
Grange Hill		8.95	1.99
Agent Orange		8.95	1.99
Red Scorpion		8.95	1.99
Nosferatu The Vamp		8.95	1.75
Theatre Europe		9.95	4.99
Battle of Britain		9.95	4.99
Battle for Midway		9.95	4.99
Geoff Capes		8.95	1.50
Football Manager		8.95	2.99
Krackout		9.99	2.99
Impossaball		8.95	2.99
Dragons Lair II		8.95	2.99
Jet Set Willy		7.95	1.99
Manic Miner		7.95	1.99
Footballer of the Year		9.95	2.99
Everyone's A Wally		9.95	0.99
Confuzion		8.95	0.99
Classic Collection		9.95	3.99
Runestone		9.95	1.99
Basketball		9.99	2.99
Two on Two Basketball		9.99	2.99
GFL Football		9.99	2.99
Future Knight		9.99	2.99
Into the Eagles Nest		9.95	3.99
Sailing		9.99	2.99
Deep Strike		8.95	2.99
Int Karate		9.95	2.99
Mask I		9.95	2.99
Super Sprint		9.95	3.99
Winter Games		9.95	3.99
Jet Set Willy II		8.95	1.99
Manic Miner/Jet Set Willy Poke		9.95	3.99
Cholo		14.95	2.99
Super Sam		8.99	1.99
Akahara		8.99	1.99
Meltdown		8.99	1.99
Quiz Quest		9.99	2.99
Gauntlet		9.99	2.99
Gauntlet II		9.99	4.99
World Games		9.95	2.99
Ace of Aces		9.95	2.99

SPECIAL OFFERS DISC		RRP	OUR
Gary Linekers Soccer		14.99	4.99
Biggles		14.95	2.99
Trivial Pursuit		17.95	5.99
Cholo		17.95	3.99
Heartland		14.95	3.99
Little Computer People		14.99	4.99
Sailing		14.99	2.99
Two on Two Basketball		14.99	3.99
720°		14.95	3.99
Who Dares Wins II		14.95	2.99
Meltdown		14.95	2.99
Equinox		14.95	2.99
Triple Pack (3 great games)		14.95	2.99
Enlightenment (Druid II)		14.99	3.99
Druid		14.99	3.99

FULL RANGE OF PCW & PC SOFTWARE AVAILABLE

S.D.C. ORDER FORM (AMSTRAD ACTION OCTOBER ISSUE)

Please send the following titles. BLOCK capitals please!
Type of computer _____

Title:-	Amount

Total Enclosed £ _____

Name _____

Address _____

Tel. No. _____

Please make cheques or postal orders payable to S.D.C. Prices include P&P within the U.K; Europe please add £1.00 per tape; Elsewhere please add £1.50 extra per tape



VISIT OUR NEW SHOP
18 MARKET SQUARE
LEIGHTON BUZZARD

FIRST BYTES

Microassembler assistance with Richard Monteiro

This month's *First Bytes* is devoted to explaining how *Micro Assembler (MA)* works. Many thanks to Des Daly for all his hard work in writing it.

It's written in Basic which means bits can be added - indeed, that's the idea. But not without your help. If you have any hints on improving Des's program, don't keep them secret: send them in!

Get going!

Insert the cassette, side two face up, into the cassette deck and type **RUN "ASMBPROG.BAS"** followed by **<return>**. Once the program is loaded you are presented with a menu:

- (1) Assemble source code
- (2) Disassemble code

Here is a quick guide round the system. Press 1 and hit Return. A prompt of the form 'Location where the source code is to be assembled to' appears. Enter

&8000 <return>. The demonstration assembler program held in memory now starts to assemble. Eventually **end** is displayed. At this instance press a key and you are taken back to the main menu.

To check that the program actually has assembled press **2 <return>** and answer **&8000 <return>** to the 'Address to start address for disassembly' question. Machine code numbers and their assembler equivalents appear. Press a key when you've had enough.

Now check to see if the program works. Press **<esc>** twice so you get Basic's **Ready** prompt. Type **CALL &8000 <return>**. Three zeros appear. Not exactly mind blowing material, admittedly, but it proves the system works.

Entering source code

If you load *MA* and type **LIST <return>**, you see that the first few line numbers

Summary

- Source code entered into Basic lines.
- Each line must start with an apostrophe.
- No spaces allowed between the apostrophe and the first assembler mnemonic.
- Opcode and address must be split by a dash - and not a comma.
- Symbolic constants start with a full stop. A dash and left square bracket used to refer to these constants.
- Reminders can be placed in the source by using a semi colon.
- Most assembler opcodes present. Logical instructions, index registers, bit operations, the stack pointer, block move commands, IN/OUT instructions aren't present and neither are interrupt commands.

look something like

```
10 'ld d-100, 20 'call-[prnt, 30
'ld d-10
```

and so on. Any line that has an abbreviated REM statement (!) as its first character is taken to be a line of assembly source. Des's program starts at line 2000 and continues through to 3780.

Source code is entered using normal Basic statements:

- line number
- space
- REM statement
- 10 'ld a-78
- address or data
- opcode
- delimiter

Note there is no space between the REM statement and the first character of the first command. Spaces cause errors - take care. Ensure that all assembly instructions are entered in lower case: failure to do so results in errors.

Most assemblers use commas to differentiate between opcode and numeric data or address - LD A,27, for instance. Not *MA*, unfortunately. Instead it uses the dash or minus sign (-). Hence a typical line of MD source would look much like 10 'a-27. This is obviously confusing to the novice so we shall supply an *MA* patch routine next month.

Numbers, which can signify either data or a memory address, can be entered as either decimal or hexadecimal. Hex numbers simply start with an & symbol - identical to Locomotive Basic's way of doing things. Last issue we discussed methods of placing values in, and retrieving values from, memory. For instance, LD A, (2341) and LD (2341), A. The same is achieved in *MA* as follows: 10 'ld a (-2341) and 10 'ld (-2341) a.

What comes next hasn't been covered in Bytes yet, and won't be for some time, so don't worry if it seems double dutch. This is here for more advanced users wishing to know all MA's features.

Symbolic constants and labels are possible with MA:

- space
- full stop
- 10 '.txt BB5A
- no & sign
- address

- dash symbol
- 20 'call -[txt
- square bracket

Another example might be:

```
10 '.adr BF00
20 'ld a (-[adr)
```

A similar technique is employed for using labels:

```
10 '[loop dec b
20 'ld a-8
30 'cp b
40 'jr nz -[loop
50 'ret
60 'end
```

Reminders too

Remarks can be placed in the source code -and work in much the same way as Basic's REM instructions - by using the semi-colon (;) after the apostrophe ('):

```
10 ';this loads HL with 10
20 'ld hl-10
```

Reminders cannot be placed on the same line as mnemonics.

Most Z80 instructions are supported, but there are particular batches of important instructions that have been mysteriously left out. For instance, all logical instructions - XOR, OR, AND - are missing. So too are all index register operations (IX and IY), bit manipulators (BIT and RES), block instructions (LDIR, LDDR, LDD etc), port addressing (IN and OUT) and interrupt handling. You will be OK without these for the time being. *First Bytes* will be adding the rest of the commands in the form of short Basic routines.

SOFT SHOP

SPECIAL PURCHASE FOR 464/6128 USERS

THE AMAZING AMDRUM DIGITAL DRUM SYNTHESISER

INCLUDING 2 EXTRA TEMPLATES ON TAPE

USUAL RETAIL PRICE OVER £52.00
ONLY £12.95

Including VAT & P&P (UK mainland only)
Overseas customers add £3.00 for Post & Packing

Orders to:
SOFTSHOP LTD
55 St Peters Court, Chalfont St Peter, Bucks.
SL9 9QQ
Tel: 0753 889010 & 0753 886947
Fax: 0753 885039

TELETEXT

A world of information
at your fingertips

A Microtext Adaptor turns your 464 or 6128 into a sophisticated Teletext Receiver. Giving you access to any of the hundreds of free pages from Cefax or Oracle. As well as up-to-the-minute news or football results, there's the local weather or even bargain holidays. And Teletext caters for special interests, like computing, motoring, or gardening, you'll find things to do and places to go in your area plus much much more.

But unlike a Teletext TV, a Microtext Adaptor allows you to do a lot more with the information, you can save a page to disc or cassette, perhaps to keep a watch on share prices, or print pages like what's on TV. There's free software too! Amstrad software is broadcast in a special format on Channel 4 for Microtext users to download. Plus you can access and use Teletext data from your own programs, providing endless possibilities.

The Microtext Adaptor fits neatly on the expansion port, it comes with software and is very easy to use. Just connect it with the lead supplied to the VIDEO OUT or AV socket of a video recorder and change channels with the controls on the video or, there's our own Tuner which has been specially designed to provide the signal that the Adaptor needs, plug in an aerial, it tunes itself in (!) and channels are selected from your keyboard. Tune into Teletext, a world of information at your fingertips.

'A well thought out product that performs admirably.'
Amstrad Action Sept. 88

A Microtext Adaptor for use with a video is only £74.95 Adaptor and Tuner just £124.90 Prices include p/p & VAT.

Instructions are provided to transfer software to disc. Disc's are available for £5.00 extra



Please send cheques/PO's to

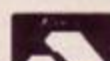

MICROTEXT

Dept AA 7 Birdlip Close, Horndean, Hants PO8 9PW
Telephone: (0705) 595694

ALL OUR PRICES INCLUDE CARRIAGE & VAT

HSV COMPUTER SERVICES LIMITED. (AA)

23, Hampstead House, Town Centre, Basingstoke, RG21 1LG

NEW!

Continuous Stationery
for your Personal Organiser
85GSM £7.95
for 250

Dust Covers

CPC 464 2pce set =£7.50
CPC 6128 2pce set =£7.50
DMP 2000 Printer Cover =£4.50

Strong water-resistant,
anti-static nylon
Grey with Royal Blue piping.

Stationery

	250	500	1000	2000
9.5" X 11" 60GSM Micro -Perf all edges	£4.50	£4.95	£8.95	£14.95
True A4 70GSM Micro-Perf all edges	£5.25	£7.50	£12.95	£22.95
True A4 90GSM Micro-Perf all edges	£8.50	£8.75	£14.95	£27.95
True A4 100GSM Micro-Perf all edges (coloured-Cream, Blue, Grey or White)		£15.95	£29.95	
Labels 3.5" x 1.5" (1 across)		£2.95	£4.95	£9.50
Labels 4.0" x 1.5" (1 across)		£3.25	£5.50	£10.50
Labels 4.0" x 1.5" (2 across)		£3.75	£6.50	£11.95
Labels 2.75" x 1.5" (3 across)		£2.75	£4.50	£8.50

AMSOFT 3" discs 1= £2.50, 5=£11.95, 10= £22.95

NO EXTRAS TO PAY

Disk Storage Boxes
3" Hinged Lid-10 cased
3" Lockable AMS-20 cased

£5.95
£9.95

Printer Ribbons

DMP 2000/3000 Black £2.95
DMP 2000/3000 Colours* £3.95

* Colours Available are:-
Red, Blue, Green, Brown,
Orange.

Credit Card

Hotline (0256) 463507 Faxline (0256) 841018



WORDS WORK

WP hints, tips and problem solving with Pat McD.

AMSTRAD 6128 AND BROTHER M1009

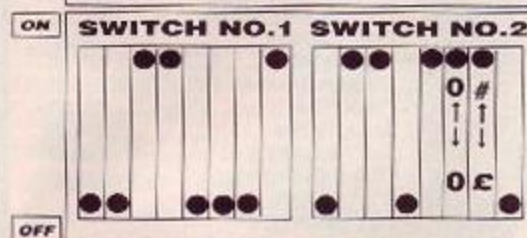

■ The skip perforation may be turned on by inserting a printer command call wherever a new page is required. The command is 27 78 n, where n equals the number of lines to be skipped. 27 67 m can be used to set the page length in lines (the value of m).

J G Robertson, Sheffield

■ I think the difficulty lies not so much in the individual make of printer, but with a general problem all printers suffer from. Printers sold in this country are set to a default paper length corresponding to American standard stationary shorter than our A4. The solution can be achieved by altering two settings from within, for example, *Tasword*.

From the main page menu, select

Look - no scissors!

■ Enclosed is an illustration for P. G. Edwards of Rosyth, who has a Brother M1009 printer. The dip switches work fine, though they disagree with the manual. I've never had any problems with page feeds or skipping the perforations, and I've used my M1009 for six years.

Paul Templar, Telford

More questions than answers

■ I, a computer illiterate, am trying to use *Protext* and *Mini Office II*. I was very interested to read the article in AA32 concerning the transfer of files created on *Protext* to *Office* or vice versa using Ascii format. I thought the instructions were straightforward enough. Alas no matter whether I created a file in program mode in *Protext* or a standard Ascii file in *Office* I could not get them to load into the other, always getting the error message **File not found**.

What am I doing wrong? Does the blank disk need to be formatted in another format other than data?

David J Board, Tavistock

■ At the moment I have a file of approximately 200 names and addresses held on the database in *Mini Office II*. I am considering buying *Protext Filer*, as I already use *Protext* in preference to the word-processor on *Office*. Unfortunately I have been unable to load my present file into *Protext*. Can it be done?

J D Ryan, Ilkley

We've had a fair few enquiries about this transfer business. So here's the unexpurgated memoirs of an ex-owner of Mini Office II.

The main problem is that Office insists on putting its own extensions on files. So wordprocessors have .TXT after the file name, database files have .DBS, and so on.

The correct procedure from Protext to Office is to load in the file, put it into program mode, and then save it with the relevant extension. You do not need a specially formatted or blank disk - merely one with enough free space.

Loading wordprocessor/database files into Protext is slightly more complicated. The problem is that, although these files do contain Ascii characters, they also contain control codes for setting up the file. These can be mistaken for an end-of-file message. This ends file loading prematurely. So it may be necessary to break down a file's length into small chunks.

Again, as AA32 stated, do remember to set the Office word processor to Ascii. This is achieved through the load/save menus.

Another point to bear in mind is that Protext does like taking its time when loading a file, often more than a minute for 12K efforts. And it seems to process them to halve their length, although all the data is (usually) there.

Customize Program and choose the page layout line. The first option refers to the number of lines per page. I find that 65 lines, single spaced and without page numbering will fill a page of A4. Enter 65 at this first line, then simply press RETURN to skip each line after that.

Secondly, go to the *Printer Control Characters* line. Here use one of the blank control letters, say P. Press P and enter the codes, each followed by RETURN: 27 67 70. This inserts them into the table. (The 70 means 70 character lines, the length of a sheet of A4.)

It's necessary to save *Tasword* to preserve the changes. Having done that, put a single sheet of paper in the printer and switch on.

With the editor screen blank, write your new printer character in the normal way (CTRL-spacebar) at the top left, go to the print routine and, having set for continuous paper, press COPY to print. The sheet goes through the printer unmarked. Remove it, line up your continuous paper and load your files for printing.

Don't switch off the printer or you'll have to re-submit the control code.

This may all seem a bit of a chore, but most of it only has to be done once. When the routine has been run the printer regards A4 as the standard length.

I want some advice now on my own problem. I am happy enough with *Tasword 6128*, but I am beginning to bump into its limitations, particularly with regard to speed. The longer the file, the slower it gets. I was working on a story of 8,500 words. It takes about a minute to go from one end of the text to the other. This is irritating when it comes to the revision and editing stage, when there is a lot of to-ing and fro-ing.

Clearly, the answer is to go for *Protext* on ROM. My problem is where to put it. I only have a small desk, and this is filled with the keyboard, monitor, printer and second drive.

I was wondering if I could raise the monitor on a suitable support and put the ROM box underneath. Does anyone make anything like this? And will I be exposing the ROM's to any electromagnetic nasties by putting them directly under the monitor? I would hate to wipe out expensive equipment just by switching on!

Stuart Falconer, Newcastle

To all those who wrote in to help: THANKS, YOU CAN STOP NOW. On the last points, a carpenter could knock up a suitable support in minutes. ROM's are erased by ultra-violet light, so putting a monitor on top should actually help to preserve them. If you're still worried, talk to your local electrical repair supplier about earthing the ROM box - this shouldn't be necessary, but would help if the device had an insufficient earth.

K & M COMPUTERS

THE LEADING AMSTRAD MAIL ORDER SPECIALISTS
• THE FASTEST • FRIENDLIEST • SERVICE AVAILABLE •

• ADVENTURES •

	CASS	DISC
Time and Magik	£10.90	£10.90
The Pawn (6128)	£14.45	
Guild of Thieves (6128)	£14.45	
Jinxter (6128)	£14.45	
Jack the Ripper	£6.99	£10.90
Mystery of Arkham Manor	£1.99	
Silicon Dreams	£10.90	£14.45
Jewels of Darkness		£14.45
Not a Penny More	£10.90	£14.45
Mindlighter	£10.90	£14.45
Gnome II: Ingrid's Back N		£10.90
Lancelot N		£10.90

• COMPILATIONS •

Coin op Connection	£2.25	
Summertime Special	£10.50	
Arcade Force 4	£7.50	£14.45
Comp. Hits 10 Volume Four	£7.50	
Konami Arcade Collection	£7.50	£13.10
4 Smash Hits (inc. Uridium +)	£7.99	£11.90
We are the Champions	£7.50	£13.10
Magnificent 7	£7.50	£13.10
Game Set and Match	£9.45	£13.10
The Elite Collection	£10.90	£14.45
Karate Ace	£10.50	£11.90
Six Pack Voll. III	£7.50	£10.90

• STRATEGY / SIMULATION •

Football Manager II	£7.50	£10.90
Pirates (6128)		£14.45
Arctic Fox	£7.99	£11.90
Gunship	£10.90	£14.45
F15 Strike Eagle	£7.50	£10.90
Match Day II	£6.99	£10.90
Red October	£10.90	£14.45
Firezone	£9.45	£13.10
BeeBee Air Rally	£5.99	£9.99
Bards Tale	£7.99	£11.90
L.Board Famous Courses N	£4.50	£7.99
Football Director (454)	£6.99	
Advanced Tactical Fighter	£6.99	£10.90
Monopoly	£7.50	£10.90
Bridge Player 3	£9.99	£11.95
High Frontier		£3.99
Steve Davis Snooker	£1.80	£7.99
Trivial Pursuit	£10.90	£14.45
P.M.S. Pegasus	£7.99	£11.90
Acro Jet	£7.50	£10.90
Vulcan	£6.99	
Silent Service	£7.50	£10.90
D. Thompsons Olympic Chall. N	£7.50	£10.70
G.Liners Superskills N	£7.99	£11.90
Night Raider N	£7.99	£11.90

• SPECIAL OFFERS •

Predator	£5.99	
High Frontier	£3.99	
Blood Valley	£2.99	£3.99
Greyfell	£1.99	
Bubbler	£1.99	£2.99
Powerplays (10 Games)	£2.25	
Leaderboard Tournament	£2.99	
Indiana Jones	£2.99	
Teach Yourself Basic (Part 2)	£5.99	
Galactic Games		£3.99
Red Scorpion	£1.99	
Agent Orange	£1.99	
Deflector	£2.99	
Firetrap	£2.99	
SabreWolf	£1.75	
Jackal		£3.99
Batman		£3.99
Clever & Smart	£2.25	£3.50
Ramparts		£2.99
720		£3.50

• ARCADES •

	CASS	DISC
Target Renegade	£6.99	£10.90
Overlander N	£7.50	£10.90
Mickey Mouse	£7.99	£11.90
Vindicator	£6.99	£10.90
N. Mansells G. Prix	£7.70	£11.80
Hotshot N	£6.99	£10.90
Sideways	£7.99	£11.90
Action Force N	£7.50	£10.90
Bad Cat	£7.99	£11.90
Elite	£7.50	£10.70
Beyond The Ice Palace	£7.50	£10.90
Road Blasters N	£7.99	£11.90
Barbarian II N	£7.50	£10.90
Alternative W. Games N	£7.99	£11.90
The Dark Side	£7.50	£10.90
Hercules N	£7.99	£11.90
Impossible Mission II	£7.99	£11.90
Shackled	£7.99	£11.90
Psycho Pigs N	£7.99	£11.90
Rimrunner N	£7.50	£10.90
Bushido N	£7.99	£11.90
Gauntlet II	£7.99	£11.90
Dream Warrior	£7.99	£11.90
Salamander N	£6.99	£10.90
Bionic Commando	£7.99	£11.90
Marauder	£7.99	£11.90
Lazer Tag	£7.99	£11.90
Pink Panther N	£7.99	£11.90
Empire Strikes Back N	£7.50	£11.90
E. Edwards Ski Jump	£7.50	£10.90
Skate Crazy	£7.99	£11.90
Captain Blood	£7.50	£10.90
Street Fighter	£7.99	£11.90
Karnov	£7.50	£10.90
Fury	£7.99	£11.90
Cyberoid	£7.99	£11.90
Arkanoïd II	£6.99	£10.90
Road Blasters N	£7.99	£11.90

• BUDGET •

European 5 A Side	£1.80
Battleships	£1.80
Yogi Bear	£1.80
Beach Buggy Simulator	£1.80
Frank Bruno Boxing	£1.80
Iball	£1.80
Thal Boxing	£1.80
Jump Jet	£1.80
Flight Path	£1.80
Juggernaut N	£1.80
Tankbusters	£1.80
Table Football	£1.80
Soccer Boss	£1.80
Ghostbusters	£1.80
Raid	£2.75
Ace	£2.75
Dark Star	£1.80
Ghostbusters	£1.80
Mr. Wino	£1.80
Popeye	£1.80
Dan Dare	£1.80
Beach Buggy Simulator	£1.80
Beach Head	£1.80
Rocky Horror Show	£1.80
Frank Bruno Boxing	£1.80
Formula I N	£1.80
Raging Beast	£1.80
Skateboard Kidz	£1.80
Superstuntman	£1.80
Sabotage	£1.80
Raging Beast	£1.80
Flight Simulator	£1.80
Superhero N	£1.80

464 UPGRADE ROM
NOW AVAILABLE
ONLY £16.95 FROM US

SPECIAL PRICES ON
A.M.S. SOFTWARE

StopPress	£39.95
StopPress & Mouse	£72.95
Mouse & Art	£61.95
Mouse Mats	£4.95
Max	£16.95

SIREN SOFTWARE
SPECIAL OFFERS

Discology	£11.95
Discovery +	£11.95
Ultrasound	£11.95
MicroDesign	£23.99
M.Mouse + C.Paint	£48.99
MasterMouse, CherryPaint & Micro Design	£63.99

MINI OFFICE II
STILL OUR No 1 SELLER
Cass £10.95 Disc £14.95

AMSOFT 3" DISCS

One	£2.50
Five	£11.50
Ten	£21.95
Twenty	£42.00

ROMANTIC ROBOT
QUALITY PRODUCTS
AT DISCOUNT PRICES

Multiface II	£44.95
Rodos (on rom)	£25.95
Rodos extras	£8.75

ALL OUR PRICES
INCLUDE VAT + P & P
NOTHING EXTRA TO PAY
IN STOCK ITEMS SENT
BY RETURN OF POST
NO MINIMUM ORDER

SPECIAL OFFER
ORDER ANY FIVE
£1.80 BUDGET GAMES
AND PAY ONLY £8

DMP 2000/ 2160 / 3000
RIBBONS

£3.99	Each
£6.99	For Two
£15.50	For Five

• ACCESSORIES •

Monitor Stand	£15.95
Rombo Rombox	£34.95
Keyboard Extension Leads	£7.99
Cover Set 464 / 6128	£7.50
Cover Set DMP 2000 / 2160	£4.50
Joystick Splitter	£7.99
Amsoft 464 Light Pens	£9.99
Spike Protection Plug	£12.50
Lockable 3" Disc Boxes (60)	£9.99
Colour T.V. Tuner	£71.95

• JOYSTICKS •

Amstrad JY2	£13.95
Cheetah Mach I +	£13.95
Pro 5000	£13.95
Cheetah 125 Special	£11.95
Delta / Joystick	£9.50
Cheetah 125 +	£7.95
Euromax Arcade	£15.95
Phasor One	£11.95
Konix Autofire	£11.95
Konix Speedking	£9.99
Cruiser (Microswitch)	£9.50

• BUS / UTIL •

Mastercalc 128	£28.95
Qualitas +	£12.99
Masterfile III	£32.95
Money Manager CPC / PCW	£24.95
Professional Adv. Writer	£24.95
Adv. Art Studio	£19.95
Adv. Music System	£24.95
Protext	£20.95
Prospell	£20.95
Promerge	£20.95
Protext Filer	£22.95
Protext CPM (Spell & Merge)	£54.95
Tasword 6128	£20.95
Matrix Spreadsheet	£28.95
Protext (on rom)	£32.50
Promerge + (on rom)	£29.95
Prospell (on rom)	£29.95

• HARDWARE •

2160 Printer	£159.95
DD1 Disc Drive	£159.95
MP2 Modulators	£29.95
FD1 Second Drive	£99.95
54k Memory Expansion	£47.95
ATARI ST SUMMER PACK	£369.00
AMIGA 500 (With Mod.)	£389.00
Amstrad / Pace Modem	£91.95
DKT Colour TV Tuner	£72.95
464 Speech Synthesiser	£29.95
6128 Speech Synthesiser	£35.95
Rombo Vidi Digitizer	£79.95

• VARIOUS •

Soldering Irons 25 watt	£7.99
SS Solder 18 swg 1/2 kilo	£10.50
Stand for Soldering Iron	£4.50
4 Way Distribution Board	£5.99
Fanfold Labels (1000)	£5.90
C15 Cassettes	45
Cases for 3" discs	25

• EDUCATIONAL SOFTWARE •

Answer Back Jnr	£7.95	£11.95
Facfile 500s	£3.75	£6.75
Fun School	£4.50	£6.75
Maxi Maths	£7.50	£11.95
The Three Bears	£15.95	
Spanish Tutor	£12.95	£15.95
French Mistress	£12.95	£15.95
Italian Tutor	£12.95	£15.95
Mapwork Quiz	£7.50	£11.95
Physics 1 12-16	£7.50	£11.95

PCW & PC OWNERS
WRITE OR PHONE FOR
PRICE LISTS
PRICES IN THIS ADVERT
ARE FOR AMSTRAD 464 / 6128

BUY WITH CONFIDENCE FROM THE LEADERS IN AMSTRAD MAIL ORDER
50p VOUCHERS SENT WITH EVERY ORDER
USE THE VOUCHERS TO DEDUCT 50p OFF FURTHER ORDERS OVER £10
WE USE AND SPECIALISE IN THE COMPLETE AMSTRAD RANGE

K & M COMPUTERS (AA),
40, FAIRSTEAD,
BIRCH GREEN,
SKELMERSDALE,
LANCS, WN8 6RD

• 24 HRS PHONE 0695 29046 •

When Ordering Please State Make Of Computer,
Please Make Cheques & P.O. Payable To K & M COMPUTERS
Overseas Inc, Eire Add £1 Per Item Of Software
We Supply Government & Educational Establishments

ACCESS ORDERS
NOW TAKEN
N = NEW RELEASE
PLEASE PHONE FOR
AVAILABILITY



AA

the first three years

A lightning tour of the many highs – and the occasional low – of three years of AA. Rather than say nice things about ourselves, however (such bad taste, don't you think?), we invited a reader, Andrew Perry – occasional contributor to *The Pilgrim* – to say nice things about us instead.

1 Oct 85: Excellent mega big first issue: The Mould-Breaking magazine from Future Publishing: 'Power-packed reviews each month on the amazing CPC 464 and 664'. Other magazines pale into insignificance set against 130 reviews, and all for a miserly pound. Wow!

2 Nov 85: The ed, Pete Connor, tries to make out that the now infamous 'WROD-PROCESSOR' mistake was deliberate.

Which wrod-processor?

3 Dec 85: Toot gets his own strip. Quality improves, but it couldn't really get any worse, could it? (*Any more of that and you're out, Perry - ed.*)

4 Christmas/Jan 86: First cover cassette. Too much seasonal festivities in the office, as *Reaction* runs to eight pages!

5 Feb 86: Best cover yet. *Sugarman's* debut.

6 Mar 86: More colour than ever before – a result of the office move to the 'glamorous' setting of *The Old Barn*? There's a new arrival: **Andy Wilton**, Technical Editor.

7 Apr 86: Educational software special, and thanks to the *Elite* mega tips I finally manage to dock at a space station.

8 May 86: Another cover cassette. The editor, **Pete Connor**, leaves. The end of life as we know it?

9 Jun 86: Though he left last issue, **Pete Connor** appears to do more in this issue than ever before. The style shifts a little towards a more 'mature' image.

10 Jul 86: **Matt Nicholson**, new ed, arrives. Best laid out issue so far, and first, and as yet only time, an adventure game – *Heavy on the Magick* – is *Mastergame*.

11 Aug 86: Final *Hi-Scores* – almost everyone was making up the scores, and trying to find out how naive the AA staff

really were. Layout continues to improve.

12 Sep 86: French special: first birthday.

13 Oct 86: Lovable white arty covers replaced by trendy photographs. **Bob Wade's** promoted from Software Editor to Deputy Editor – is it because he was shown you could use the keyboard as well as a joystick?

A Production Editor, **Jim Nagel**, arrives.

14 Nov 86: Editor **Matt Nicholson** leaves, and in comes **Jim Nagel** – talk about rapid promotion! Start of *A Day in the Life*, beginning with a look behind the scene at AA GHO, *The Old Barn* itself.

15 Dec 86: New regular feature called *Hot Tips*. Departure of **Andy Wilton** and arrival of Tech Ed **Richard Monteiro**.

16 Christmas/Jan 87: Cover cassette which for a change doesn't ruin the cover when you take it off.

17 Feb 87: **Jim Nagel** returns to Production Editor. In his place comes games player supreme, **Bob Wade**. All this work editing and play-testing games takes its toll and *Starglider* is made the month's *Mastergame* (yuk!).

18 Mar 87: Drastic cut in the number of cartoons, new rating system in *Action Test* and restyled *Pilgrim*, whose cowl was beginning to look a little ragged. Round up of all available word-processors (or wrod processors), the most informative piece so far.

20 May 87: Worst cover ever – sacrilegious mistreatment of a CPC.

21 Jun 87: Price rises to £1.25. AA moves offices to Bath. Best cover ever.

23 Aug 87: New regular column called *Words Work*. *Small Ads* begin. Results of latest AA questionnaire.

24 Sep 87: 2nd birthday. **Toot** returns with a vengeance to celebrate. Much staff upheaval. Out goes Art ed, **Trevor Gilham**, and in comes **Ollie Alderton**. **Jim Nagel** leaves as well.

(Do they know something we don't?)

25 Oct 87: New staff writer, **Gary Barrett**.

26 Nov 87: Midi music special. For the first time no AA *Raves*.

28 Christmas/Jan 88: Now traditional seasonal cover cassette, and equally traditional seasonal torn cover. First edition of the *Pilg's Rod and Staff Monthly*, free to all followers of the straight and narrow path (who buy AA).

29 Feb 88: Cover blurb becomes the familiar 'BRITAIN'S LEADING MAGAZINE FOR THE AMSTRAD CPC 464, 664 AND 6128'. Rundown of the available spreadsheets.

30 Mar 88: Rpm responsible for premature deaths of hundreds of 464's as owners, screwdrivers in hand, try to turn them into 6128's.

31 Apr 88: *Bar CPM* starts. Great article on *CPC: The Facts*. *The Pilgrim* joins in with a look at the future of CPC adventuring world.

32 May 88: First *Perry's Piece* in *The Pilgrim*. Circulation soars as someone in Worcester buys several thousand copies. (Also available for panto.)

33 Jun 88: New Tech Ed **Pat MacDonald** seems to write entire mag. *Soldering On* and *Comming Online*

begin. *Wargaming* special; *Buyers Guide* for graphic and musical utilities.

34 Jul 88: Shock horror probe scandal: **Bob Wade**, only original member of the team, edits his final issue with tears in his eyes and bulge in his wallet.

35 Aug 88: Arrival of **Steve Carey** (who features on the front cover, before he got a haircut).

35 Sep 88: Issue Number *Confusion Special*.

37 Oct 88: 3rd birthday, and a fascinating article about the first three years of AA.

Happy third birthday AA, from a loyal and satisfied reader! Where's the cheque? (*What cheque? -ed.*)



EXCLUSIVE - MONEY OFF!
Romantic Robot offer £3 off the Insider when
you enclose this coupon and send it BEFORE
OCTOBER 31st.
AA OCTOBER 1988

BREAK IN

Gary Barrett boldly goes where no program has gone before -
inside Romantic Robot's Multiface Two

THE INSIDER

Romantic Robot ● £14.95 (& £1 p&p)
Disk only

Long ago in the early days of the CPC there was born a small black box that lived in the expansion slot at the back of the computer and had two buttons on top of it. With this mysterious box, known as the **Multiface Two**, you could transfer games from cassette to disk, display and edit memory, and do the same with the Z80 registers. Now you can delve deeper into the CPC with the aid of the *Insider*.

Getting inside

The *Insider* comes on a single disk and must first be installed into the **Multiface**. It couldn't be easier: just type `RUN"DISC"` and away you go. A message tells you that the *Insider* is OK.

The first step is to press the infamous red button and watch the screen. Rather than the usual menu bar across the bottom you're instructed to insert the *Insider* disk. When you put the *Insider* disk in you're presented with a menu: lower Rom on/off, upper Rom on/off, printer on/off, linefeed on/off, Ram bank select, return, disassembler, Z80, find, text, number, poke, hex and dec. All options are accessed by a single keypress. Hex fairly obviously changes all input and output to hexadecimal and dec returns it to decimal. The return option exits from the *Insider* and you go back to whatever program you'd interrupted with the **Multiface**.

The lower Rom on/off options toggles between the CPC's operating system Rom and the Ram bank which goes from &0000 to &3FFF. Ploughing through the Rom can provide you with insight into the way the CPC works. More often than not though you'll want the lower Rom off so you look around the memory. Upper Rom on/off works like the lower Rom on/off option only this time the swap is between the Basic Rom and Ram from &C000 to &FFFF. If you have more than 64K of memory you can switch banks using the *Insider*'s Ram bank number option. The bank

The programmer's point of view

During program development you occasionally crash the system, and can do nothing but turn the machine off and re-load. With the *Insider*, though, you can just hit the red button and see where the program went wrong. A quick look at the registers and flags tells you where the program counter is pointing and that gives you some-

where to start looking for the bug. You're not guaranteed to find it, but the chances of tracking it down are increased with the ability to search a crashed system.

If nothing else you can still revert the **Multiface** to its normal mode of operation and save memory out to tape or disk for examination at a future date.

appears from locations &4000 to &7FFF. The contents of all of the CPC's registers can be displayed with the Z80 option. Both the normal and alternate register sets are shown.

A find option enables you to search for a string of either Ascii characters or numbers in Rom or Ram. An Ascii search is useful if you want to find passwords, vocabularies or just silly messages left by the programmers and a number search can be used to hunt

Multiface Two+ ● £47.95 (&£1 p&p)

Insider ● £14.95 (&£1 p&p)

Romantic Robot UK Ltd, 54 Deanscroft Ave, London NW9
8EN ☎ 01-200-8870

If you want to delve deeper into the CPC the firmware guide is a must. It lists the various routines in the CPC and explains entry condition, exit conditions and what each routine does.

Soft 968, Firmware guide for all CPC's ● Amsoft ● £19.95 ● Brentwood House, 169 Kings Road, Brentwood, Essex CM14 4EF ☎ 0277 230222

The hacker's point of view

People have been hacking into games since there have been games to hack and now the protection systems used are getting more and more sophisticated. Games are often encoded, so that they must be decoded before they can run.

With the **Multiface** you can stop a program when it has all been decoded and see the code as it really is.

Checking the contents of the program counter gives

you somewhere to start looking for pokes, and if that fails you can always search through memory for the number of lives, shields, energy etc. Once you've found something you want to try it's just a matter of poking that address with an appropriate value and returning to the game. If the poke works the problem's solved, and if it doesn't you just hit the red button again and try something else.

down those elusive infinite lives pokes. The address at which the string was found is printed - or you get a not found message. If the string was found you can search again to see if it occurs elsewhere in memory. Once you've found the address that you want to change you can use the poke option. With this you're asked for an address and a number to put there.

There are three ways to look at memory: text, number and disassembly. In text mode the contents of the memory locations are displayed in Ascii form. Messages and passwords appear before your eyes as you scurry through memory. Number mode is the same as Ascii except that hex or decimal numbers are displayed instead of letters.

Now for the interesting bit: the disassembler. Disassemblers are invaluable for debugging and hacking into programs, but because of their large size they often overwrite some of the code that you want to disassemble. With the *Insider* you don't get that problem because it sits inside the **Multiface's** Ram.

The disassembler itself can handle all of the Z80 instructions including the undocumented ones often found in commercial programs. The disassembly is tabulated into three columns: number, mnemonics and Ascii. The left hand column gives the contents of memory in either hex or decimal and the right hand column shows the contents of the same locations in Ascii. The central column has the assembly language mnemonics with numbers displayed in either hex or decimal, depending on which number base the *Insider* is in.

The *Insider* requires some knowledge of assembly language and the Z80 to yield its full potential. The program itself is not dif-

THE SECRET OF IMMORTALITY

How to use the Insider to poke a game: *Side Arms* (US Gold) gets infinite lives

● Install the *Insider* into the **Multiface** by typing `RUN"DISC"` with the *Insider* disk in the drive. (If you have a **Multiface Two** make sure that the switch on the front is in the down position.)

● Insert the *Side Arms* disk in the drive and type `RUN"DISK"`.

● When the game has loaded press the red button on the **Multiface**, put the *Insider* disk in the drive and press **Return**.

● The number of lives that you have in *Side Arms* is three, but only two blobs are shown on screen to indicate lives remaining. At some stage during the game a location in memory must be set to the number of lives you have and one of the most common methods of doing this is:

```
LD A, lives
LD (address), A
```

To find all occurrences in which the **A** register is loaded with two press **F** on the keyboard and you'll end up in the find routine. Press **1** on the keyboard to enter the list of bytes that you want to search for. In this case you're looking for `LD A, 2`, which in hex is `3E 02`. Type `3E (Return)`, `2E (Return)` and then press **Return** again. (The final return is used to tell the *Insider* that you don't want to enter any more numbers to be searched for.)

● Press **3** to select the start address from which you want to search and type in `0 (Return)` to start right at the bottom of memory.

● Press **4** to start the search and up should come the message `** Found at 01CC **`. Note this number. If you press **4** twice more it comes up with two more addresses: `0685` and `9F59`. Note these addresses too. A third press of the key gives you `01CC` again which means that you've found all occurrences of `LD A, 02` in the game.

● Press **5** to get back to the main menu and then press **D** to use the disassembler. Enter `01CC` as the address when asked and press **Return**. The screen shows the first six lines of disassembly for the address `01CC` onwards. You're looking for an `LD (address), A` instruction somewhere nearby to store the number of lives in a memory location.

● This line of attack looks unproductive, so try the next address that was supplied, `0685`. Return to the main menu and do the above using `0685` as the address instead of `01CC`.



● Side Arms as you see it; and (below) as the Insider sees it

● This time it looks more promising, with an `LD (06B2), A` at `0690`. Return to the main menu again and find `B2, 06` this time (the number `06B2` is stored in memory as `B206`). Only two occurrences of the number appear in the game at `068A` and `0691`.

● Since we're looking for references to that address in memory rather than the actual memory address we disassemble from slightly before the addresses that were found.

● Disassemble from `0689` and you see the following:

```
LD HL, 06B2
ADD A, (HL)
JP M, 06F4
LD (06B2), A
```

The **HL** register is pointing to the address `06B2` and then the **A** register is added to the contents of `06B2`. `JP M, 06F4` means to jump to `06F4` if the contents of the **A** register is negative.

● Do another find – this time for `0689` – and learn how many times a call is made to the subroutine at `0689`. Only once is there a reference to that routine, at `0672`.

● Disassemble from `0671` and you see `CALL 0689`.

● Now go for it. Assuming a call to that routine is used to decrease the number of lives that you have, all you have to do is to stop the game from calling that subroutine.

In the **Z80** there is an instruction `NOP` which does absolutely nothing. It may seem useless, but in hacking games it's very useful indeed. The hex equivalent of `NOP` is `00`.

● To stop the game from executing the `CALL 0689` instruction we just fill those three locations with `NOP`. Go back to the main menu and press **P** for poke. When asked for an address type in `0671` and then type `00`. Poke `00` into the two following address of

`0672` and `0673`.

● It's time to try it out and see if it has worked. Go back to the main menu and press **R** to return to the game. Start playing the game and lo and behold you now have infinite lives.

● As you can see from this example poking is not a simple business, and requires more discussion than we have space for here. How much of *AA* we dedicate to this subject depends on your reaction...

difficult to use, but if this is the first time that you've used a disassembler you may have problems. If you use the *Insider* simply to put pokes into games then you may as well stick with the basic **Multiface**. If on the other hand you want to wander around memory and explore the inner workings and secrets of the **CPC**, or even just find your own pokes, the *Insider* is an invaluable addition to the **Multiface**. Machine code programmers should seriously consider it as a debugging aid.

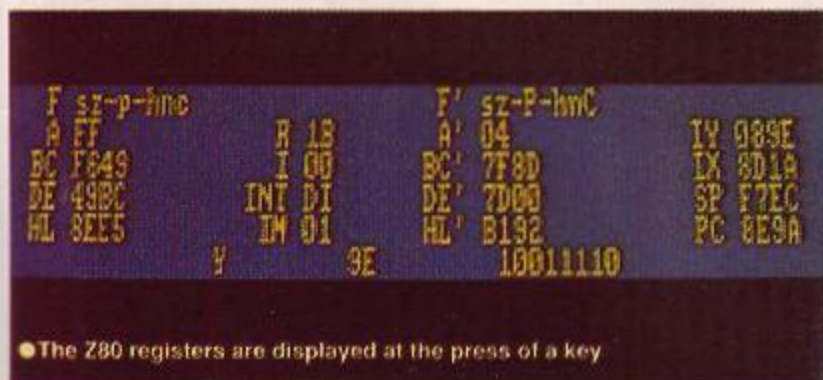

● The **Z80** registers are displayed at the press of a key



● A name from the past in the lower Rom

GOOD NEWS

- Disassembles all **Z80** Opcodes.
- Can send output to printer and screen.
- Invaluable both for hackers and programmers.

BAD NEWS

- Accesses disk too often.
- Only available on disk.
- Only works with the **Multiface**.



Heroes of the Lance

- US Gold's great smash and grab!



Fancy a weekend in the country's oldest inhabited castle, with a night in a medieval bedchamber, a medieval banquet and all the mead you can quaff? Fancy being let loose in the country's best software shop to grab all the software you can? Fancy free copies of US Gold's *Heroes of the Lance*? Fancy free copies of the brand new £20 'DRAGONLANCE' boardgame?

OF COURSE YOU DO! And all of these things are yours, if you can just answer our four questions in the great AA 'Dragon' competition. Simply put your answers on the back of a postcard or stuck down envelope (positively no envelopes opened or correspondence entered into!) and rush it immediately to: *Heroes Competition*, 4 Queen St, Bath BA1 1EJ.



THE COMPETITION

1. What world are the 'Dragonlance' adventures set in?
2. Who is the saint who killed a dragon?
3. What is the name of the dragon in 'The Hobbit'?
4. According to Chinese astrology, what began on 17 February 1988?



THE PRIZE

You and a friend will:

- SPEND an all expenses paid weekend at Penhow castle, the oldest inhabited castle in Wales;
- SLEEP for a night in the medieval bedchamber (a guesthouse room is reserved in case your nerve fails!) and
- DINE in a medieval banquet.

You will also:

- SMASH AND GRAB as much software as you possibly can in the space of one minute from Liverpool's BITS AND BYTES, software retailer of the year, in an all expenses paid trip.

And it goes without saying (but we'll say it anyway) you will also receive:

- A copy of *Heroes of the Lance*, AND
- A copy of the new TSR 'DRAGONLANCE' boardgame
- An exclusive AA teshirt.

RUNNERS UP

SECOND prize is a heap of TSR/US Gold goodies:

- 'The Art of Dragonlance' book - a history of Krynn, the world of Dragonlance;
- 'The Atlas of Krynn';
- A complete set of the Dragonlance novels;
- A 'Dragonlance' 1989 calendar;
- US Gold's *Heroes of the Lance*;
- And the new TSR 'Dragonlance' boardgame.

FIVE third place runners-up each receive *Heroes of the Lance*, PLUS the 'DRAGONLANCE' boardgame;

FIVE more runners-up receive *Heroes of the Lance*, and finally,

FIVE more runners up each receive the 'DRAGONLANCE' boardgame

The competition closes on 31 October 1988, and is not open to employees of US Gold, Future or Penhow castle or their relatives.

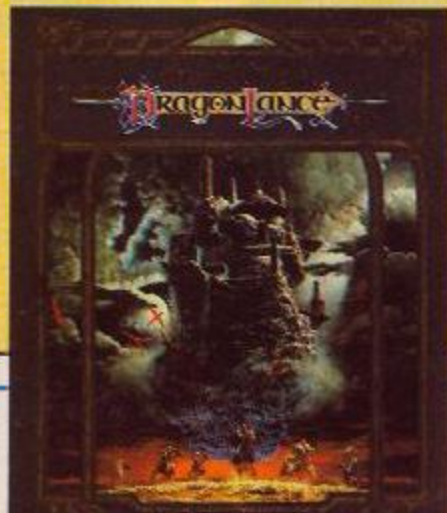

PRE-SCHOOL, PRIMARY, JUNIOR

Education



Designed by
Experienced Teachers
For use in School and Home

Wide range of programs
For AMSTRAD CPC - PCW - PC1512

CASSETTE £9.00 - DISC £12.00
Send SAE for List. Stating Amstrad
model and child's age.

As reviewed in Amstrad Action - May 1988

ARC (ACT 10), 51 Coniston Crescent, HUMBERSTON,
SOUTH HUMBERSIDE DN36 4BA. (0472) 812226

ZENITH SOFTWARE

Z-PACK

Complete Z80 Machine Code Tool-Pack
For All Hackers, Meddlers and Machine Code Enthusiasts.
Some of the features

• **FULL SCREEN MEMORY EDITOR**
View ROM. Alter and view RAM including the extra banks
(on 128k machines).

• **Z80 DISASSEMBLER**
Disassemble RAM or ROM easily and quickly, send
output to screen, printer or an ASC11 file on disc.

• **CALCULATOR**
Enter hex, decimal and binary numbers to add, subtract,
multiply, divide, AND, XOR and OR.

• **POWERFUL BLOCK COMMANDS**
Define a block of memory simply by placing a couple of
markers from within the memory editor, you can then Alter
Block, Move Block, Search Block, Print Block and Save
Block.

All commands easily accessed just by the press of a key.
Supplied on a 3" Amsoft disc, complete with a quality
manual. Two versions supplied one for 64k machines
and one for 128k machines.
ONLY £10.95 INC. P+P

• **EXTRA BANKS OF RAM (128k Machines)**
Select the extra banks of RAM to view, alter, save,
move, etc.

• **SELECT LOWER/UPPER ROM**
Select a ROM to view, save, disassemble, move, etc.

• **BAR COMMANDS**
Including ZPACK, CAT, ERA, REN, etc.

• **BREAKPOINTS**
Place a breakpoint in memory, when code is executed
and a breakpoint is found the register-pairs are
displayed, at this point you can either exit back to Z-
Pack or continue with the code.

ZENITH SOFTWARE
11 Bude Street, Appledore,
Bideford, North Devon. EX39 1PS

POOLSWINNER II

THE ULTIMATE POOLS PREDICTION PROGRAM

- **MASSIVE DATABASE** Poolswinner is a sophisticated Pools prediction aid. It comes complete with the largest database available - 22000 matches over 10 years.
- **PREDICTS** Not just SCOREDRAWS, but AWAYS, HOMES and NO SCORES.
- **SUCCESSFUL SELEC guarantee** that Poolswinner performs significantly better than chance.
- **ADAPTABLE** Probabilities are given on every fixture - choose as many selections as you need for your bet. The precise prediction formula can be set by the user - you can develop and test your own unique method.
- **SIMPLE DATA ENTRY** All team names are in the program. Simply type in the reference numbers from the screen. Or use FIXGEN to produce fixture list automatically (see below).
- **LEAGUE AND NON-LEAGUE** All English and Scottish League teams are supported, and also the non-league sides often used on pools coupons.
- **PRINTER SUPPORT** Full hard copy printout of data if you have a printer.



PRICE £18.00 (all inclusive)



FIXGEN 88/9

AT LAST! No more struggling for hours to get the fixture list into the computer. FIXGEN has been programmed with all English and Scottish League fixtures for 1988/89. Simply type in the date, and the full fixture list is generated in seconds. Fully compatible with Poolswinner. Yearly updates available.

POOLSWINNER with FIXGEN £19.50 (for both)



COURSEWINNER v3

THE PUNTERS COMPUTER PROGRAM
NOT JUST A TIPSTER PROGRAM, Coursewinner V3 can be used by experts and occasional punters alike. You can develop and test your own unique winning system by adjusting the analysis formula, or use the program in simple mode. Coursewinner V3 uses statistical analysis of major factors including past form, speed ratings, course statistics, prize money, weight, going, trainer and jockey form etc. etc. It outputs most likely winners, good long odds bets, forecasts, tricasts etc. The database includes vital course statistics for all British courses. You can update the database - never goes out of date. **FULL PRINTER SUPPORT.**

PRICE £18.00 (all inclusive) includes Flat AND National Hunt versions.

AVAILABLE FOR

All supplied on tape ...
(Automatic Conversion to disc)

AMSTRAD CPCs
BBCs
COMMODORE 64/128
SPECTRUM

DISCS ...

(Add £3.00)

AMSTRAD PCW
IBM Format
COMMODORE AMIGA
ATARI ST

Send Cheques/POs for
return of post service to ...



62 ALTRINCHAM RD, GATLEY, CHEADLE, CHESHIRE SK8 4DP. ☎ 061-428 7426

(Send for full list of our software)

NEMESIS - THE ORIGINAL MEDDLERS

BONZO SUPER MEDDLER (FOR ANY CPC)

"THE BEST TAPE to DISC TRANSFER UTILITY AVAILABLE" WACCI 6/88

THE dedicated TAPE TO DISC utility
includes the devastating
BONZO's HACK PACK

BONZO SUPER MEDDLER is GUARANTEED TO TRANSFER MORE GAMES THAN ANY OTHER PROGRAM: THE FIRST PERSON TO FIND A MORE SUCCESSFUL PROGRAM WILL RECEIVE TREBLE THEIR MONEY BACK!! BONZO uses LESS memory, transfers MORE, COSTS LESS and gives REAL support to the user.

THE 1988 VERSION

Clearly the best in 1987, BSM & HACKPACK began 1988 with up to the minute refinements, **NOW EVEN MORE VERSATILE.** Return your old BSM DISC with £3 for a full upgrade.

** Details of **OVER 700 TRANSFERS** supplied. **

Other advertisers will tell you little gems about their utility handling AMSDOS filenames correctly, BONZO does too - big deal! Here's something more interesting, 50 out of the 700+ that transfer with the latest BONZO SUPER MEDDLER.

AVENGER, ANARCHY, ANTIRIAD, ARKANOID, ARMY MOVES 1&2, BARBARIAN BACK TO THE FUTURE, CAULDRON 1 & 2, COMBAT ZONE, CHP, BASKETBALL, COPOUT, DRILLER, EQUINOX, ENDURO RACER, FOOTBALLER OF THE YEAR, FROSTBYTE, GRAND PRIX SIMULATOR, GOONIES, HARVEY HEADBANGER, HERBERT'S DUMMY RUN, INTERNATIONAL KARATE, JACK THE NIPPER, KNIGHTMARE, KILLAPEDE, LIVING DAYLIGHTS, LEADERBOARD, MICROBALL, MOLECULEMAN, METALYX, NEXOR, OBSIDIAN, PRO SNOOKER SIMULATOR, QUARTET, QUESTOR, REFLEX, SKATEROCK SIMULATOR, SUPERSPRINT, SIDEWALK, STARRAIDERS II, SOUTHERN BELLE, STARWARS, SPACEACE, SPINDIZZY, SCRABBLE, TETRIS, THRUST 1&2, ULTIMA RATIO, VAMPIRE, WONDERBOY, XOR, ZUB, ZOIDS, 3D GRAND PRIX, SWORD SLAYER, BEACH BUGGY SIMULATOR.

Check these against your existing utility. 'NUFF SAID'

BSM & HACKPACK DISC £12.50 - Only

NEMESIS (AA)
10 Carlow Road, Ringstead
Kettering, Northants NN14 4DW

Tel: (0933) 623967

BONZO'S DOO - DAH

"This is the best I've seen in a long while.... I recommend it"
- AMSTRAD ACTION, JUNE 1987.

FEATURES BIGBONZO FORMAT

A REALLY USABLE 203K PER SIDE FORMAT, with all the support files to maximise it's use. **PLUS** - All the disc housekeeping features that you could possibly want, including "Cloning", Directory & Sector edit, Disc search, Formatting, Read sectors, Filecopy, etc. ALL FUNCTIONS are effective on normal, enhanced, and the vast majority of "funny formats".

MANY UNIQUE FEATURES. Supplied on DISC - £12.50

BONZO BLITZ - NEW SPEEDLOCK'S to DISC!!

A TOTAL utility for SPEEDLOCKS, straight to DISC from TAPE!

ABSOLUTELY NO "JUGGLING" -

"HIGHLY RECOMMENDED", WACCI, 12/87.

WHAT CAN IT DO?

There's not many that it can't do! BLITZ works on a standard 464 as well as the 6128 & expanded machines. All our claims are based on user reports. A small selection for flavour!

GAMEOVER, SLAPFIGHT, MAG MAX, MARIO BROS., ARMAGEDDON MAN, ARMY MOVES, F15 STRIKE, GREAT ESCAPE, BLACK MAGIC, WARLOCK, SPACE SHUTTLE, METRO-CROSS, DIZZY, TRANSMUTERS, SHAO LINS RD, ARKANOID, COBRA STALLONE, DALEY'S SUPERTEST, TOP GUN, MIKIE, SCALEXTRIC, SARACEN, SHORT CIRCUIT, EXPRESS RAIDER, XEVIOUS, TOURNAMENT LEADERBOARD, SCRABBLE, FREDDY HARDEST 1&2, MADBALL, MATCHDAY II, PHANTOM CLUB, SUPER HANG ON, DAN DARE II, SUPER STUNTMAN, RACE AGAINST TIME ETC.
Return your old BLITZ disc with £3.00 for full upgrade.

DISC ONLY - Just £12.50 inc

MORE BONZO GOODIES

BONZO'S FLASHPACK

"BEST ALL ROUND BASIC EXTENSION PROGRAM SEEN". WACCI 3/1988
A STUNNING ENHANCEMENT TO "LOCO" BASIC **DISC. £12.50**

BONZO'S BIG BATCH

A VERSATILE DATABASE, A POOLS PREDICTOR, AND A MODE 0 SPRITE/SCREEN DESIGNER. **DISC. £12.50**

ALL WITH FULL INSTRUCTIONS & AFTER SALES SUPPORT
ORDERS by CHEQUE, P.O.'s ACCESS, sent by return.
(OVERSEAS please add £1.50 to total)

AA HELPLINE

Helps and pokes on loadsagames

John Hudson, 14 Yetlands, Dalston, Carlisle, Cumbria CA5 7PB ☎ 0228 0625

Hardware problems incl. DMP 2000 and 'normal' 5.25 inch (not Vortex). Loads of type-ins from German CPC mags. Experience in CP/M+; help with Basic bugs, machine code and millions of games

Jotti A, Rallenstr. 10, D-2500 Oldenburg, W. Germany ☎ 01049 441 52726 (hope you enjoyed your trip to London -ed.)

Paperboy, Terminus, Jail Break, Curse of Sherwood, Nemesis, Transmuter, Hunchback, Johnny Reb, Ghost'n'Goblins, Destructo, 3D boxing & lots more

Inigo Dunkley, 62 Rainbow Drive, Melling, Liverpool, L31 1BZ ☎ 051 547 2714

Multiface users - end SAE for cheat sheet. Pokes for many top games (Multiface only)

Stephen Trimmer, 24 Vale Rd, Broadstairs, Kent CT10 2JQ ☎ 0843 603258

Machine code, hacking, writing RSXs and ROMs. Maxam 1.5, Protex, RODOS, DMP2000, DDI-1.

Matt Cawley, 42 Hamilton Ave, Sandycroft, Dee-side, Clywyd CH5 2PB

Brunword, printers.

M Catton, 11 Battery Close, Gosport PO12 4PA ☎ 0705 585764

Free amateur radio & PD software, ROMs, electronics disk power supplies.

J.M.Dunnott G4RGA, 5 Queens Rd, Wellington, Somerset TA21 9AW ☎ 082347 4911

Loadsagames.

Iain McKinnon, 37 Loch Laidon St, Sandyhills Estate, Glasgow, G32 9HR

Grand Prix Simulator, Who Dares Wins 2, Speed King, Paperboy etc. plus pokes, maps, trillions of programs and help with Basic and machine code.

Steven Flynn, 76 Dunlop Rd, Tilbury, Essex RM18 7AU

Sorcery, Alien (free map), Star Wars, Rebelstar, Armageddon Man, Rogue Trooper. SF penpals.

Paul Scott, 13 Kiln Crescent, Bishop Middleham, Co Durham DL17 9AP

Oblivion, Locomotion, One Man + his Droid, Army Moves, Space Harrier, Project Volcano, Thunderzone, Gunstar.

James (11) ☎ (0458) 73926

Loadsagames and company addresses.

Scott Patterson, 8 Moor Lane, Thornton, Liverpool L23 4TW

AA type-ins, Basic, DMP 2000, Adventure programming, Laser Basic, screen dumps, most football games.

Adrian Sill, 19 Sherwood Drive, 5 Lane Ends, Skelton, Doncaster, South Yorkshire DN6 8NY

Will supply disk of windows for use with Advanced OCP art Studio containing software logos, game logos, title screens. Free if disk sent or disk for £2.75.

Stephen Trimmer, 24 Vale Rd, Broadstairs, Kent CT10 2JQ ☎ (0843) 603258

Roadrunner, Sorcery +, Football Manager, 180, Head

over Heels, and about six million more (KEEP 'EM SHORT!)

Steph Godrich, 215 Trewyddfa Rd, Morriston, Swansea SA6 8NX ☎ (0792) 793208

Matchday II, Buggy Boy, Tetris, Nigel Mansell's Grand Prix, Soccer Boss, Jet Bike Simulator, Super Stunt Man.

Craig Thomson, ☎ (0698) 51177

Raid, 180, Star Raiders II, Beach Head II, Death Wake, Sir Lancelot, Footballer of the Year, Nonteraqueous, SD Snooker, GP Simulator, Leaderboard, Desert Fox, Aliens, Champ Basketball, Champ Baseball

Michael Dickinson, 281 Tyldesley Road, Atherton, M29 9AL

Loadsagames.

Craig Thomson, ☎ (0698) 51177

Solving Basic bug, most machine code programs. Enclose listing - description of program +) If poss enclose cassette with program on 454 only. If machine code enclose assembler listing.

Paul Jones, 78 Fitzwilliam Street, Swinton, Rotherham, S.Yorkshire, S64 8RW

Converting programs for the Vortex disk drive. Simple machine code. Hacking. CP/M programs & utilities. A whole bunch of public domain programs.

Mark de Bont, de Foes 15, 5581 AP, Waalre, Holland, ☎ (04904) 13963

Radzone, Ghosts and Goblins, Knight Tyme, Dragons Lair, Green Beret, Gauntlet, Feud, Starquake (codes), Bounder, Boggit.

David Brooke, 8 Birkby Grove, Bilton Grange, Hull, HU9 4PZ

Knight Tyme, Spellbound, machine code, Basic, Word Perfect, Melbourne Draw, GAC, pokes, maps, hacking, DMP 2000 problems, games development using GAC, word-processing, graphics (screen dumps), all CPC games. Can also print program listings for a 40p postal order. How to do pokes and problems using modems. (I have a Voyager?)

Guy Sicka, 78 Chesterfield Road, High Barnet, Herts, EN5 2RF ☎ (01) 441 5612

Basic programming, some machine code.

Paul Bower, Elm Gable, Hermitage, Newbury, Berks. RG16 9SA ☎ (0635) 200891

Tasword 6128/Tas-spell 464 & 6128, Tasprint, Tascopy, Basic programming, Masterfile III, Locksmith+, Masterdisc, Epson LX printers, CPM and help on then game Elite.

Oystein Kjaereng, Torvymrv.42, 3170 Sem, Norway

Basic, machine code, Laser Genius, tape loading,

disk loading, firmware, graphics, sound, hints, pokes, mapping, Word Perfect, Sorcery+, Transmat, Oddjob, Warlord, Kung Fu Master, Bruce Lee, Bounder, Gunfright, Pip, will print listings for 20p

Steven Lawson, Plot 77, Meir Park, Staffordshire, ST1 6HQ.

De-bugging Basic programs, basic listing at 50p E/A

Tom Daffin, Crawley Farm House, South Brewham, Near Bruton, Somerset, BA10 0LB

GAC adventure writing and problems. Also conversions to other formats undertaken for published GAC authors by fellow established author.

C.Sharp, 4 Osprey Gdns, Sheffield, S2 5GE, S.Yorks

Bombjack, Green Beret, Doomdarks Revenge, Lords

of Midnight, Thrust, Barbarian, Kung Fu Master, Elite, Hunchback, Feud, Everyone's a Wally, Who Dares Wins 2, Grand Prix Simulator, Kane, Hyperbowl, Ikari Warriors, Fist, Yie Ar Kung Fu, Bruce Lee, Jack the Nipper, Fourth Protocol (part one only), Knight Tyme, Ghost'n' Goblins.

Paul Crich, 33 Hills Road, Strathaven, Lanarkshire, ML10 6LQ ☎ (0357) 29606

Gauntlet 1+2, Green Beret, Bombjack 1+2, Zub, Starquake, Equinox, Bounder, Space Harrier, Exolon, Elite, Tau Ceti, Trapdoor, Star Wars Freddy Hardest, Batman, Head Over Heels, I Ball II, Popeye, Firelord, MK Trilogy, L.O.M., Antirad, Split personalities, Renegade Motos, Tempest, Mikie, Ninja.

David Howlett, 53 St Marys Avenue, Alverstoke, Gosport, Hants, PO12 2HU

Raid, 180, Star Raiders II, Beach Head II, Death Wake, Sir Lancelot, Footballer of the Year, Nonteraqueous, 3D Boxing, SD Snooker, GP Simulator, Leaderboard, Desert Fox, Super Cycle, Aliens, Champ Basketball, Champ Baseball

Michael Dickinson, 281 Tyldesley Road, Atherton, M29 9AL

Ranarama, Exolon, Zynaps, Alien 8, Head over Heels, Jack the Nipper, Batman, Thundercats, Super Robin Hood, Feud, Stormbringer, Ghost Hunters, Galvan, The Great Escape. Plus maps for loads of games, send a list of 5 games max to be mapped free.

Martin Grover, 11 The Croft, Lower Dicker, Hailsham, East Sussex, BN27 4BS

Stop Press, Extra-Extra, Sorcery+, Ikari Warriors, Knight Lore, Barbarian, 1942, Who Dares Wins II, Bomb Jack, Bomb Jack II, Exolon, Seastalker, Asphalt, Gauntlet, Gauntlet II, Protex, Prospell and the DMP 2000. I also have a huge number of pokes and maps.

Pal Kroger, Bergjevegen 62, N-4056 Tanager, Norway

Mini Office I (program that removes all bugs, send SAE), business program (word processor, spreadsheet, graph display etc.) written by myself, send cass or disk and SAE, Defektor, Gauntlet II, Matchday II.

Paul Graves, 46 Queens Road, Ash, Canterbury, Kent

Feeling helpful? Just send your name, address, phone number (say if you don't want it printed) and subjects on which you're offering help to: **Helpline**, Amstrad Action, 4 Queen Street, Bath, BA1 1EJ. Write on a postcard/back of a stuck down envelope and keep it short or you won't get in (or you'll get cut to 'loadsagames').

If you want help contact the appro-

priate Helpliner - not us. By post include a self-addressed, stamped envelope for the reply - or you won't get one. And phone only in decent hours!

Piracy is not welcome: don't try it, you'll get booted off. Keep it legal. And if you receive SAE's, for heaven's sake return them with some acknowledgement. If you want to come off **Helpline** write and say so.

HOT TIPS

Can you take a hint?

The missing link

I forgot to let you know how to load Smart II screens back into the CPC from within Basic. Here goes:

```
10 MODE 0:MEMORY &3F00:LOAD "file-
name.BIN", &3F00
20 CALL &BC06, &40:LOCATE
1,26:PRINT:PRINT
30 FOR f=0 to 15: INK
f, PEEK(&3F00+f):NEXT
```

Use this line to save Smart II screens in more conventional format:

```
40 SAVE "newname.bin", b, &4000, &4000
```

Multiface unlimited

Perhaps *Multiface* owners would like to know what code lurks within. Using the toolkit, poke this code into address &BF00:

```
F3, 01, E8, FE, ED, 49, 21, 00, 00, 11, 00, 40, 01, 00, 40, ED, B0, 01,
EA, FE, ED, 49, FB, C9
```

Which in assembler is:

DI	Disable Interrupt
LD BC, &FEE8	Select Multiface I/O Port OUT (C), C
LD HL, &0000	Source of data in Multiface
LD DE, &4000	Destination in CPC RAM
LD BC, &4000	Data length
LDIR	Transfer all data

```
LD BC, &FEEA Select CPC I/O OUT (C), C
```

```
EI Enable interrupt
```

```
RET Return to Basic
```

After poking in this code press ESC, R to return to normal. Enter CALL &BF00. When the Ready prompt re-appears type: SAVE "MFROM.BIN", b, &4000, &4000. You should now have on disk or tape a copy of the entire 8K ROM plus the 8K RAM. Of course, if you just want the ROM or RAM you could alter the saving parameters.

Now you can load the code into a dis-assembler and discover the Multiface code for yourself.

Ian Bentley, Doncaster

Print out enhancement



● Before (above) and after (below). Neat, n'est pas?

The ESP light pen is good on the whole except in its choice of tones used to represent the different colours on the printout. These have no relation to the grey scale value of the colour, and the defaults give some strange looking results.

Use the following program instead of the DUMP program supplied in conjunction with the chart to choose suitable tones for the printout. This program works on all modes. It calls up ESPDUMP so if you want DUMP on your data disks remember to transfer this also.

Don't worry that the picture on screen looks terrible because all that matters is what the printout looks like.

```
10 'ESP lightpen program
20 'Amstrad Action October 1988
30 'Modified by Marco Bergman
34 '
35 'For x in line 40 use whatever
36 'type of printer you have (1, 2 or 3)
40 i$="x"
50 OPENOUT "d":MEMORY &FFF:LOAD "espdump.bin"
60 DEF FN A=&1000-&200*(i$="2")-&400*(i$="3")
70 INK 1,26:INK 0,0:PEN 1:MODE 1
80 PRINT TAB(13)"ESP SCREEN DUMP"
90 PRINT:PRINT TAB(9)"( P to start printing )"
100 PRINT
110 PRINT "ink 0 :";:INPUT " ",q0
120 PRINT "ink 1 :";:INPUT " ",q1
130 FOR q=2 TO 15:PRINT "ink";q:": ";:INPUT " ",i$
140 IF i$="" THEN i$="26"
150 IF i$="p" THEN 170 ELSE i=VAL(i$)
160 INK q,i:NEXT
170 CLS:INPUT "Enter name of screen: ",n$
180 PRINT:INPUT "mode ",m:MODE m
190 INK 0,q0:INK 1,q1
200 LOAD n$:CALL FN A
210 WHILE INKEY$="" :WEND
220 RUN 60
```

Marco Bergman, New Zealand

Yet more calls

Here are a couple of tips for 6128 owners:

CALL &BD38	permanently activates caps lock.
CALL &BD20	Flashes the screen.
POKE &BDDE, &79	Disables soft reset (CTRL/SHIFT/ESC)

Phillip Brooks, Long Eaton

We welcome your contributions to *Hot Tips*, and the best published each month earn their author £20. So what are you waiting for?

Address your work to: *Hot Tips*, *Amstrad Action*, 4 Queen St, Bath, Avon, BA1 1EJ.



Castle Computers

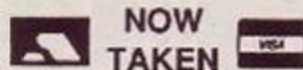

Castle House,
11 Newcastle Street,
Burslem,
Stoke-on-Trent,
ST6 3QB
Tel: 0782 575043

SALE SALE SALE SALE SALE SALE SALE SALE SALE SALE SALE

AMSTRAD CLEARANCE

Armageddon Man	3.95
Auf Wiedersehen Monty	2.75
Agent Orange	1.99
Avenger	1.50
Aliens US	2.99
Aliens UK	1.99
Bride of Frankenstein	1.99
Bubbler	0.99
Battle of Britain	3.95
Battle for Midway	3.95
Beyond the Ice Palace	6.95
Bionic Commandos	6.95
Ballblazer	1.99
Basil Gt Mouse Detective	2.99
Captain America	2.99
Captain Blood	7.25
Championship Sprint	3.95
Combat School	3.95
Challenge of Gobots	1.99
Cholo	2.99
Centurions	1.99
Contamination	1.50
Cosmic Shock Absorber	0.99
Cyberoid	6.99
Dan Dare	1.70
Dandy	0.99
Dark Sceptre	3.95
Domarks Revenge	2.99
Doomsday Blues	1.50
Dambusters	1.70
Deathville	1.50
Elite	7.50
Eye	2.99
Equinox	1.75
Escape Singes Castle	1.99
Elevator Action	1.50
Four Smash Hits	6.99
Fairlight	1.99
Future Knight	1.70
Fighting Warrior	0.99
Frankie Goes to Hollywood	1.75
Galactic Games	2.99
Gauntlet	2.99
Gauntlet II	4.95
Gladiator	1.99
Gothic	3.95
Greyfall	1.50
Grangehill	1.99
Guadal Canal	2.99
Gunsmoke	3.95
Hot Runestone	1.50
Hjack	1.50
Hive	0.99
Hopping Mad	6.95
Inheritance	1.99
Impossible Mission	1.70
Impossible Mission II	6.95
International Karate	2.50
International Karate +	3.95
Jackal	2.99
Johnny Reb II	2.99
Kinetic	1.50
Knightmare	3.95
Lazer Tag	4.95
Legions of Death	3.95
Lord of the Rings	3.95
Leviathan	1.99
Magnetron	3.95
Marauder	6.95
Mario Brothers	3.95
Mutants	1.99
Mag Max	2.99
Mystery of the Nile	1.99
Nigel Mansels G. Prix	7.25
Nomad	1.25
Nexor	1.50

GUNSHIP RRP £14.95 OUR PRICE £10.95

Out of This World	1.25
Preditor	6.50
Pulsator	1.25
Quartet	2.99
The Quill	3.95
Rampage	3.95
Ramparts	2.99
Red Scorpion	1.99
Road Runner	3.95
Renegade	3.95
Rygar	3.95
Staine	2.99
Saboteur 2	2.25
Shogun	2.99
Skate Crazy	6.95
Space Harrier	3.95
Spy v Spy: Arctic Antics	1.99
Survivor	2.99
Shockway Rider	1.50
Street Fighter	6.99
Strike	0.99
Supersprint	2.99
Shard of Inovar	0.99
Samurai Trilogy	2.99
Target Renegade	6.50
Trantor	3.95
Trap Door	1.70
10th Frame	1.50
Theatre Europe	3.95
Thing Bounces Back	2.99
Thundercats	3.95
Tai Pan	2.99
Throne of Fire	2.99
Thundercats	6.25
Vixen	6.75
World Games	3.95
Warlock	1.75
Xevious	0.99
The Young ones	1.99
Xor Games Designer	3.95
Yes Prime Minister	2.99
Yogi Bear	1.99
Yie Ar kung Fu	1.99
Popeye	1.70
Strike Force Cobra	1.70

AMSTRAD CASSETTE COMPILATIONS

SUMMER GOLD
10th Frame, Dambusters, Bruce Lee,
Beachhead II, Rebel Planet, Impossible
Mission.
ON OFFER AT £4.95

PLAY IT AGAIN
10th Frame, Express Raider, Supercycle,
Metrocross, Leaderboard, Impossible
Mission, Leaderboard Tournament.
ON OFFER AT £4.95

TEN GREAT GAMES VOL 2
Auf Wiedersehen Monty, Samurai
Trilogy, Convoy Raider, Jack the Nipper
II, Basil Mouse Detective, Death Wish 3,
Mask, The Duct, Thing Bounces Back,
The Final Matrix
ALL FOR £6.95

WE ARE THE CHAMPIONS
Super Sprint, Renegade, Rampage,
Inter Karate +, Barbarian
5 TOP GAMES £6.95

ARCADE FORCE 4
Indiana Jones & Temple of Doom,
Metrocross, Road Runner,
Deeper Dungeons
NOW ONLY £6.99

COIN OP CONNECTION
Breakthru, Crystal Castles,
Express Raider, Metrocross
BE QUICK AT ONLY £2.99

4 SMASH HITS
Zynaps, Exelon, Rana Rama, Uridium +
NOW ONLY £6.95

PACK OF ACES
Inter Karate, Boulderdash, Nexus,
Who Dares Wins II
AT ONLY £3.95

PRESTIGE COLLECTION
Rescue on Fractalus, The Eidolon,
Koronis Rift, Ballblazer
**MEGA COMPILATION AT
£3.95**

MAG 7
Wizball, Short Circuit, Arkanoid, Head
Over Heels, Cobra, The Great Escape,
Frankie Goes to Hollywood,
Yie Ar Kung Fu
8 OCEAN GAMES FOR £6.99

TARGET RENEGADE
IN STOCK AT £6.50

AMSTRAD DISC

Frankenstein	3.95
Slap Fight	3.95
Through the Trapdoor	3.95
Design Design	2.995
Shockway Rider	2.99
Electraglide	2.99

GUNSHIP ON DISC
RRP £19.95
OUR PRICE £13.95

**JUST ARRIVED
720°
SPECIAL PRICE
£3.95 ONLY**

Mutants	2.99
Hydrofool	2.99
Big Trouble in Little China	3.95
Leviathan	2.99
Yogi Bear	3.95

INFOCOM TITLES

Ballyhoo	9.95
Planetfall	9.95
Soastalker	9.50
Suspended	9.95
Spellbreaker (6128 only)	9.50
Suspect	9.50
Cutthroats	9.50
Hollywood Hijinx	9.95

Book of the Dead	3.95
Glen Hoddies Soccer	3.95
Cobra	3.95

**HELP! we must clear all of
our stocks of Amstrad discs
this month! PHONE NOW,
They won't last long!**

Warlock	2.99
Ninja Hamster	3.95
Mario Brothers	3.95
Cholo (back in stock)	4.95

DRUID II ENLIGHTENMENT NEW IN AT £4.95

Nemesis Final Challenge	3.95
Bridge	3.95
Short Circuit	2.99
Clever & Smart	2.99
Spy v Spy	3.95
Galactic Games	3.95
Firetrap	3.95
Nightmare	3.95
Frankenstein	4.95
Renegade	3.95
Colossus Bridge	4.95
Shogun	3.95
Wonderboy	4.95
Jackal	3.95

ALL CASSETTE

720°	3.95
Guadal Canal	2.99
Super Sprint	2.99
Quartet	2.99
Combat School	3.95
Yogi Bear	1.99
Impossible Mission II	6.50
World Games	3.95

REMEMBER!

We'll beat anybody's price so
make that phone call now
0782 575043

Postage & Packing 50p on all orders
under £5, Over £5 P&P free

ACTION TEST

The very best CPC entertainment

Heroes of the Lance – the game AD&D'ers have been eagerly awaiting – is almost here: and we have a full review beginning on page 38!

If it's flying action you're after, there's a stunning simulation from Microprose in

which you fly an Apache AH-64 and kill people in the name of democracy (ho hum).

Then there's the Patrol Hydrofoil Missilecraft simulation *PHM Pegasus*, Electronic Art's third big hit in a row.

Also we – oops out of room!

Action Test index		
Mastergame	<i>Heroes of the Lance</i>	38
<i>Raves</i>	<i>Bubble Ghost</i>	43
<i>Gunship</i> 40	<i>Dream Warrior</i>	43
<i>PHM Pegasus</i> 36	<i>Marauder</i>	45
	<i>Overlander</i>	45
Games reviewed	<i>Skate Crazy</i>	35
<i>Action Force</i> 44	<i>Uridium</i>	46
<i>ATV</i> 44		
<i>Bionic Commando</i> 46		

SKATE CRAZY

Gremlin ● £9.99 cass, £14.99 disk joystick/keys

You have skateboarded. You have biked. You have even scootered. But this is the first time that there has been a roller-skating game. Not only that: you get two games for your money – car park challenge and the championship course.

Car park challenge is set (go on, guess) in a multi-storey car park. Each level is set out with cones, cans, ramps, tyres and boxes. Arrows are painted on the floor to guide you around the course.

The car park is viewed from slightly above ground level, with you in the centre of the screen. Four judges sit at the bottom of the screen watching to see how well you do. Each is looking for a



● Leap through the air in the car park challenge

different thing: overall skating, course, jumping from ramps and jumping from the floor. Overall skating includes jump landings and backwards skating.

The course judge (isn't a course judge one who swears a lot?) keeps track of the time between gates and of how many cans you knock over: the more the better. Judge number three studies your jumping from ramps and scores you on the complexity and variety of stunts you execute and the floor jumping judge does the same for jumps from the ground.

The Verdict

GRAPHICS69%

- Smooth scrolling in both games.
- Bright and colourful graphics.

SONICS53%

- Good continuous tune in car park challenge.

GRAB FACTOR74%

- One of those games that demands you play it just one more time.
- Frustrating until you work out how to get a decent score for jumping.

STAYING POWER66%

- Plenty of levels to work through...
- but not a game that you'll come back to after completing it.

AA RATING70%

- If what we've told you suggests it's for you – it *is* for you!

After you complete the course the judges score you. If you score high enough then you go onto the next course and if you don't you'll have to try again.

Your view point in the championship course has changed completely to a side view of the skater. Your task this time is to reach the end of the level avoiding the many hazards.

SECOND OPINION

"Makes a pleasant change from endlessly shooting and chopping things. It's a racing game that's actually been quite well done and I had a few moments of fun playing it."

I'm a bit doubtful about its long term appeal, but the game is of a standard that merits interest."

PbM

GREEN SCREEN: No problems

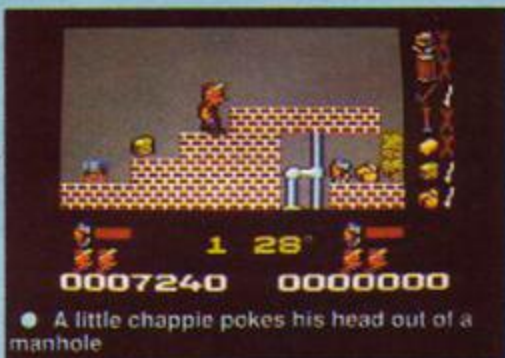

● A little chappie pokes his head out of a manhole

Bonus points can be gained by collecting some of the objects that litter the humpy landscape. Colliding with the scenery knocks you over and after you've been hit several times you lose a life. Lives are also lost if you fall into the water.

Both the eight way scrolling in car park challenge and the horizontal scrolling in the championship course are smoothish and fast. The graphics are a bit on the chunky side, but colour is used well. A frenetic tune plays throughout the car park challenge and sound effects in both are good, if a little on the rare side.

Neither game in itself is particularly spectacular, but combine rather nicely. Both lose out on difficulty: they're too hard until you've played them a lot and learnt how to perform stunts and negotiate the hazards successfully. All in all a genuine first-class Gremlin goodie. **GBH**

FIRST DAY TARGET

Complete level one of car park challenge



PHM PEGASUS

Electronic Arts • £8.95 cass, £14.95 disk joystick/keys

Two thirds of the earth's surface is covered with water, so it's hardly surprising that the seas and oceans have often been the scenes of battle. Sea warfare in the eighties still involves missile and projectile combat, but the weapons are a little more sophisticated than arrows and rocks. The fastest ships in modern navies are the hydrofoils which skim across the surface of the water at very high speeds. The star of this strategy/simulation is a patrol hydrofoil missilecraft (PHM).

Included with PHM is a manual containing information on the eight assignments you can undertake, an explanation of the cockpit instrumentation and a similar description of the operations map. There's also a breakdown of hydrofoil's weaponry and capabilities, and a spotter card to help identify enemy shipping.

SECOND OPINION

'PHM has a lot going for it - an effective view, well drawn ships, easy controls and achievable goals.

A pity the maps are a bit plain, but at least it all fits into memory. Worth a look.'

PbM

GREEN SCREEN: No problem

There are two screens: a cockpit view from the hydrofoil, and the operations map. The cockpit view is split into smaller windows: a view from the bridge, a binocular view, information of weaponry, speed, fuel, direction, the time factor and a damage indicator. The operations map shows both the area in which the assignment is set and your hydrofoil.

The eight missions get progressively more difficult: from **Battle Training**, a simple introduction to hydrofoil combat, right up to **Jihad** (as in the Islamic Holy War), for the most experienced naval officer. Once you've chosen a mission the operations map appears with your hydrofoil indicated by a dot within a small white circle. If the convoy is visible, or

you have any helicopters, then they can also be directed from the operations map. A clock at the bottom of the screen shows the current time and time by which the assignment must be completed. You can watch your hydrofoils progress from the operations map until something exciting happens or you can go to the cockpit view and look out over the ocean.

One feature that makes things happen more quickly is the **time compression function**, which speeds things up by as much as 128 times real time - there's no waiting around for something to happen in this game! Other companies should take note of this feature that prevents players getting bored waiting for things to happen.

Eventually you find some enemies to despatch and the game becomes more simulation than strategy. Simply choose your weapon and target and get blasting.

There are three ways the game can end: **completing the assignment**, **running out of time** and **being sunk**. Your score is considerably better if you complete the mission because you receive a **survival** and **time bonus**. After the assignment you're given a rank that indicates how well or badly you did. It shouldn't take long before you've gone above the rank of **Deck Mopper**.

The operations map lacks a little in colour and things do get a little confused when there are multiple radar targets displayed. In the cockpit the only real moving graphics appear in the window that overlooks the ocean and here the ships aren't animated - they just move left and right as the hydrofoil turns. The ship outlines are well drawn and you can easily identify the ships from a side view. Unfortunately you see the enemy head-on more often and since there are no head-on pictures on the spotter card you'll have difficulty identifying the different enemy types. Sound is limited to crude explosions and the occasional



warning sound when missiles are locked on, or you're in shallow water.

PHM may not be the most

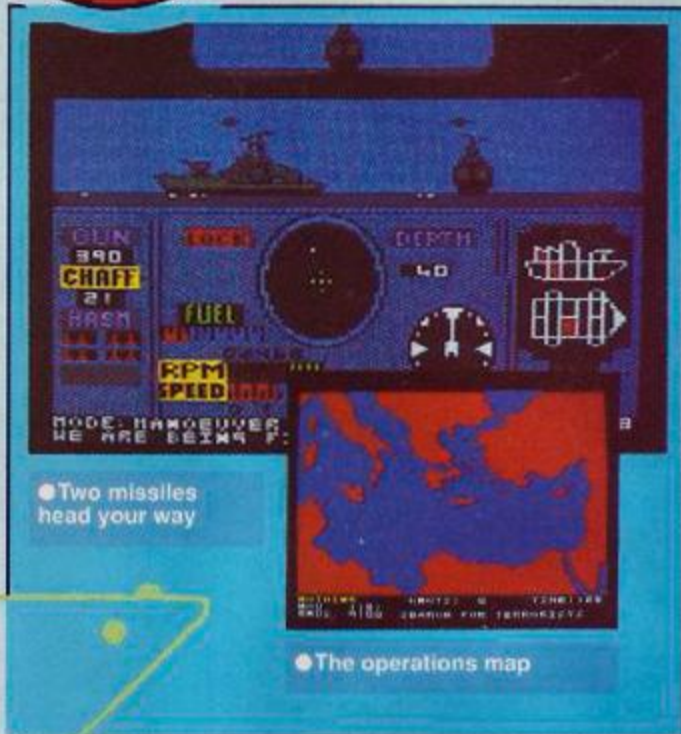

● Two missiles head your way

● The operations map

technically accurate simulation (that honour is split between *Gunship* - reviewed this month - and *F15 Strike Eagle*), but it does have plenty of action and strategy thrown in. Being able to speed up the clock to 128 times real time is a major

The Verdict

GRAPHICS68%

- Detailed ships and map.
- Some animation would have made things more interesting.

SONICS29%

- Kaboom and ping.

GRAB FACTOR79%

- Simple scenarios get you going.
- Rush-through -boring-bits option.

STAYING POWER ...86%

- Eight increasingly tough scenarios.
- Once completed, never repeated.

AA RATING84%

- Another superb Electronic Arts game.

Gun shells: short range, inaccurate. Sinks small vessels after only a couple of hits.

Chaff: defensive weapons system that confuses enemy radar guided weaponry.

Harpoon Missiles: blows enemy out of the water up to 40 miles away.

Gabriel Missiles: similar to harpoon, but slightly more accurate and of shorter range.

Exocet Missiles: the most famous anti-shipping missile since the Falklands war.

Binocular View: shows picture of ship or helicopter you're locked onto.

Radar: tracks enemy missiles and vessels within detection range.

Helicopters: longer radar range aids in the location of your enemy.

Damage: different areas of the ship house different systems. The more often they're hit the less reliable they become until finally they're disabled completely.

asset in getting through the boring bits of an ocean voyage. The different assignments make for a long lasting game, but you're unlikely to play again when they've all been completed. This is the third game in as many months from Electronic Arts and it's of the same high standard. Let's hope they keep up the good work.

GBH

FIRST DAY TARGET:
Complete 'A Better Part of Valour'

FERNANDEZ COMBAT

In the distant jungles of Central America, revolution is in the air. The government of the Democratic Republic of El Diablo has been brutally overthrown and the evil despot known only as Fernandez rules the land.

Summoned by the exiled leaders of your homeland, you must free your people from the oppressive yoke of the Dictator by destroying the military bases that have protected

Fernandez from the wrath of his people.

- Jeeps, tanks, motorcycles, trains and more
- Huge play area
- One or two player options (some formats only)
- Map of El Diablo
- Free 'Fernandez' badge
- 'Fernandez' poster and T-shirt offer



Atari ST screen shots shown

Spectrum disk: £12.99
Spectrum cassette: £8.99
Commodore disk: £12.99
Commodore cassette: £9.99
Amstrad disk: £12.99
Amstrad cassette: £9.99
ST: £24.99
Amiga: £24.99



Heroes of the Lance

US Gold ● £9.95 cass, £14.95 disk joystick



● Hatchling black dragons are tough little critters

The long awaited **Advanced Dungeons and Dragons (AD&D)** has finally arrived on the CPC. Unfortunately it's not a role playing game, but you can't have everything. *Heroes* is set in the fantasy world of Krynn, a world in which the Dragon Highlords and their Draconian minions seek to dominate. It's based on the AD&D role playing supplement *Dragons of Despair*, set in the ruins of the temple of Kak Tsaroth. A party of adventures undertake a quest to recover the Disks of Mishakal from the depths of the temple. The Disks are guarded by Khisanth, an huge and ancient black dragon. Many dangers await before you finally confront Khisanth.

There are two areas to the screen: the action window and the character window. In the character window are pictures of the eight heroes: **Tanis**,

SECOND OPINION

"As a rabid follower of the *Dragonlance* books – although not a player – I am impressed with US Gold's efforts.

It reminds me of the *Gargoyle* games (Tir Na Nog and Dun Darach). Except it's much better. Furthermore I suspect that this is one game I could actually solve.

It has to be said that the graphics aren't much and sound isn't much: but the game remains faithful to the rich tradition of *Dragonlance* and the world of Krynn."

PbM

GREEN SCREEN: Fine



● A portal in the back wall leads Caramon to another section of the temple



● Raistlin casts a magic missile at a Baaz Draconian



● Goldmoon leaps across a pit

Goldmoon, Caramon, Raistlin, Sturm, Riverwind, Tasslehoff and Flint. Next to each picture is a bar indicating the character's health (hit points). The rest of the screen shows your surroundings and a picture of the currently selected character (top left in the character window).

Control of the characters is all done via the joystick. You can make them run, jump or duck to the left and right. When there's a suitable exit you can move into or out of the screen too. If a monster is also on screen then you can either use ranged combat or charge in and hack at them in melee. Ranged combat includes spell casting, bows, spears and other throwable objects.

A press of the space bar opens up a large menu window with the following options: **character select, magic spells, clerical spells, use, take, give, drop,**

Party time



Tanis is the half-elven leader of the group. He's armed with sword and bow and wears magical leather armour.



Goldmoon, a human cleric from Que-shu tribe, carries the blue crystal staff, a potent magical artifact. She is the only person capable of using the staff to its full potential.



Caramon Majere is a human fighter armed with sword and spear. He's the twin brother of Raistlin.



Raistlin Majere is a magic user who carries a Staff of the Magi, with which he can cast a multitude of spells. He's crippled – but still manages to jump further than any other character!



Sturm is yet another human fighter. He prefers to use his magical two-handed sword than any other weapon.



Riverwind is also from the Que-shu tribe. He was slain by the people of his village, but **Goldmoon** resurrected him.



Tasslehoff Burrfoot is a Kender thief. The kender are a small race of people with an insatiable curiosity, which has led to their reputation as excellent thieves.



Flint Fireforge finishes off the eight. He's a dwarven fighter armed with a battleaxe and throwing axes.

save and restore. The latter two options are essential in a game of this size. **Character select** allows you to switch the character that appears on screen, which is useful if one is getting badly injured or you want Goldmoon to resurrect someone. **Take** lets you pick things up and **drop** does the reverse. With **give** you can move objects from one character to another and **use** allows you to drink potions, read scrolls, wear rings etc.

Raistlin can cast the following spells from his Staff of the Magi: burning

MASTER GAME



● Tanis's character sheet



● Spells available from the Blue Crystal Staff

hands, charm, sleep, magic missile, detect magic, detect invisible and final strike. Goldmoon can similarly cast clerical spells from her Blue Crystal Staff. They are: cure light wounds, protection from evil, find traps, hold person, spiritual hammer, prayer, cure critical wounds, raise dead, restoration, deflect dragon breath. If Goldmoon dies then Riverwind, Caramon or Sturm can use the Staff, but only cure light wounds, find traps, cure critical wounds and deflect dragon breath can be used. But that's not all: if she does die things begin to go badly wrong for the party, because you have no way of getting dead characters back. The commonest cause of demise in the early stages of the game is falling down pits and consequently losing the body and all its possessions. Without a body it's tough: you can't resurrect a character. Characters can also die when they take damage from spell and melee combat. The wounds can be healed by use of the cure spells unless the character dies, in which case it's raise dead time again.

Sound - merely a matter of combat and spell casting effects - is limited, and graphics distinctly lacking in colour, though they make up for it a little in detail. Characters run and jump around very well and the ones in cloaks look very dynamic as they leap over pits. Both monsters and heroes are well animated and easily identifiable. Background



● Flint Fireforge throws an axe at a Bozak Draconian

graphics are also detailed and objects lying around the temple can be identified with no problems.

First impressions of *Heroes* are that you've got a game with average graphics and simple sound effects. It takes a few plays before you realise just how much game you've got for your money. A lot of it does look similar, but as you explore the temple you discover more foes and hazards. AD&D artwork has always been of a very high standard and it's good to see that the computer games are getting the same sort of quality artwork on the packaging. Definitely the best game from US Gold this year. Let's hope they do even better with future AD&D projects, and that this sells enough to persuade them to convert them for the CPC. **GBH**

The Verdict

GRAPHICS63%

- Well animated and detailed monsters and heroes.
- Colour could have been used better.

SONICS43%

- Sound effects are simple, but do their job.

GRAB FACTOR86%

- Many things to do and objectives to achieve.
- Pit jumping is very difficult and frustrating.

STAYING POWER93%

- Very large playing area to explore.
- Most of the fun is in exploration and so if you do complete it then you probably won't play again.

AA RATING92%

- An excellent game from US Gold. It's been well worth the wait.

● Late production difficulties, it seems, may delay the appearance of *Heroes* in the shops. Thus there may be features that do not appear in the pre-production version on which this review is based. These, however, should be minor, and in any case will be improvements. If anything, the game you'll see could be even better!

A bestiary of Xak Tsaroth



Baaz Draconians are the smaller of the two draconian races met in Xak Tsaroth. They have a taste for human flesh, but can be killed quite easily. When they do die they crumble into dust.

Bozak Draconians are slightly larger and nastier than their kin, they also have rudimentary magical abilities. When they die they explode injuring anyone too close to them.

Giant Spiders lurk in some areas of the temple. They're unintelligent and treat anything that moves as food. Their small size makes them difficult to hit.



Gully Dwarves are the result of interbreeding between dwarves and gnomes. The result is a cowardly race that will plead for mercy if they have an opportunity.

In the early stages of the game the most dangerous thing that you'll meet are the *Hatchling Black Dragons*. They don't like getting close enough for you to hit them, preferring to breath on you which can cause a lot of damage.



Khusanth the huge ancient black dragon is your final enemy. He can breath acid over you, claw and bite or hurl magic spells at you. Defeat him and the

Disks of Mishakal are yours.

Within the temple you'll also meet *Men* in the employ of the Dragon Highlords. They're all experienced warriors armed with swords and they wear leather armour.

Spectral Minions are the spirits of dead humans or demihumans who failed to complete some quest in life. They look as they did when they were alive except that now you can see through them.



Trolls may not be the most intelligent lifeform in the temple, but they are one of the more dangerous. They carry no weapons, instead attacking with claws

and teeth. Killing them is no simple matter, for unless you completely burn their corpses they have a tendency to get up again after you've killed them.

Wraiths are the undead spirits of evil beings cursed to stay in the world of the living. Their touch is deadly, not so much for the damage that it inflicts, but for the life force that they drain from you.



GUNSHIP

Microprose ● £14.95 cass, £19.95 disk
joystick only

Now, at long last, you too can sweep into the skies in an Apache AH-64 helicopter – blasting liberals, pinkoes and out-and-out commies as you go. Yes, you've guessed, it's an American chopper: the latest, in fact. Packed with electronics, armed to the teeth, armoured beyond belief – and costing millions. Costly business, war.

get demoted, for some odd reason (which probably says more about the game than it does about me).

To help you fulfill your missions there is the usual Microprose doorstep of a manual. Flying helicopters is a notoriously tricky job, but start by the book and you should be at least able to get into the air without much trouble. As much practice on the American range as you can stand is highly recommended because all the flak is simulated. Even in the relative calm of

home territory, however, you can still go west/go for a burton by taking on a hill.

All potential targets are listed in the manual, together with many I could never find. Hard targets you have no trouble at all finding are **T74 tanks**, **BMP** and **BTR infantry carriers**, **SAM (surface to air missiles)** and **ZSU (Zenitnaia Samokhodnaia Ustanovka** – that's Russian anti-aircraft gun to you, pal) **armoured vehicles** and **military bunkers**.

Soft targets are helibases, depots and headquarters, and of course the infantry. Coming into a special category of its own is the Hind, the Russian attack helicopter that can outrun you and is as well armoured as the Apache. It has a nasty habit of popping out from behind a hill to shoot you up an experience you may well not live to regret.

To destroy all these there are four weapon systems available:

- The **all-purpose chain gun** fires High Explosive Dual Purpose rounds, effective against hard as well as soft targets. It tracks with the TADS (see below).

- **FFARs (Folding Pin Aerial Rockets)** are simple unguided weapons that produce a big bang when they hit something. They are very inaccurate, but deal with soft, dispersed targets well enough.

- **AGM-114As**, more commonly termed **Hellfires**, are **laser guided anti-armour weapons** that pierce hard targets very effectively, but they can't harm soft targets. They're extremely accurate – unfortunately you can only carry a maximum of 16.

- **AIM-9Ls** are widely known as **Sidewinders**. These **AAMs (Air to Air Missiles)** are included in most simulations. They home in on heat sources and are so sensitive they can find the wings and fuselage of aero-

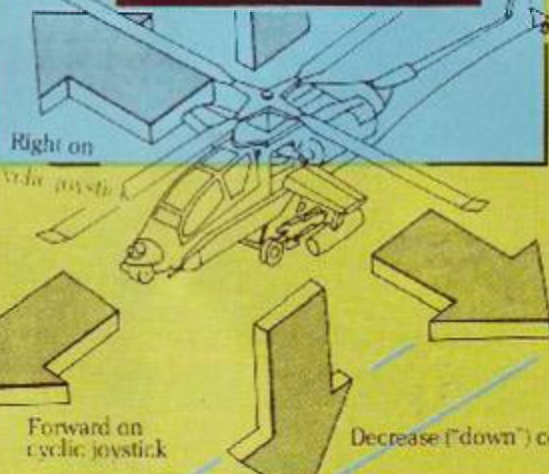
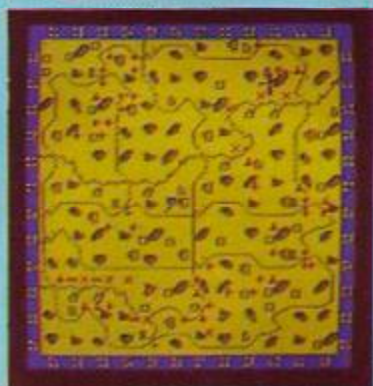

This flight simulation has been grounded on the Amstrad until now, and pretty displeased we CPC users have been about it too. Indeed, your campaigning AA was making its feelings known about it in *Amscene* as long ago as *AA25!* But to their credit the Microprose coders kept on bashing away, and their patience has at last been rewarded.

But *Gunship* is not just a simulator. You chart the career of a pilot in the US Army. Start off on training flights in the USA. Progress by taking some tours in 'South-East Asia'. Take on the Nicaraguan forces fighting in Central America. The Arabs in the Middle East are causing trouble – blow them away. Ultimately, the Warsaw Pact has invaded Western Europe. Naturally enough, you've got to kill them all. *Gunship*: diplomacy with a vengeance.

If this sort of American behaviour (known throughout the free world) doesn't appeal to you, then you probably won't like the game. Complete the missions as stated and you get promotions and medals. Your reviewer could never

SECOND OPINION

"Microprose are well known for simulations and this is certainly their best to date. Not only is it very realistic and surprisingly fast, but it's also fairly easy to play without wading through the huge manual. More advanced players will still find the game challenging and you can build up quite a collection of medals over your piloting career.

The manual contains much information that's irrelevant, but nevertheless interesting. There's also a quick start option and a handy keyboard overlay to make things a little easier during play.

There are two companies that show everyone else how to do it when it comes to simulations: Microprose and Digital Integration. Microprose have moved into pole position. Now it's up to Digital Integration to try and reclaim the title.

One last thing that might help you make up your mind: tape owners should beware that this is a continual multi-load game."

GBH

GREEN SCREEN: Tricky but playable

planes, rather than depending on flying up the exhaust pipe of an engine. Use them on the Hind.

In present-day warfare, the real usefulness of aircraft lies not so much in their flying ability as their use at finding and destroying the enemy. The main aids for this are electronics – or to use the correct term, **avionics**.

The Apache has an extremely impressive array of gadgets. TADS (**T**arget **A**cquisition/**D**esignation **S**ystem) is the heart of the Apache, and consists of a laser, TV camera and infra-red sensor. The system is located under the chin of the helicopter and does all the hard work for you, pinpointing and identifying targets. Two other useful gadgets are the **radar** and **infra-red jammers** which serve to confuse enemy search and guidance systems for cannon and missiles. The drawback is that switching them on makes you more obvious – and enemy gunners have eyeballs to track you with as a backup system.

Cruder methods are also available to confuse the enemy electronics. **Chaff** is the nickname for the anti-radar system which launches thousands of strips of aluminium, causing lots of blips on radar screens. **Flares** are simply lumps of magnesium that burn at a high temperature, producing multiple targets for infra-red weapons to lock-on to.

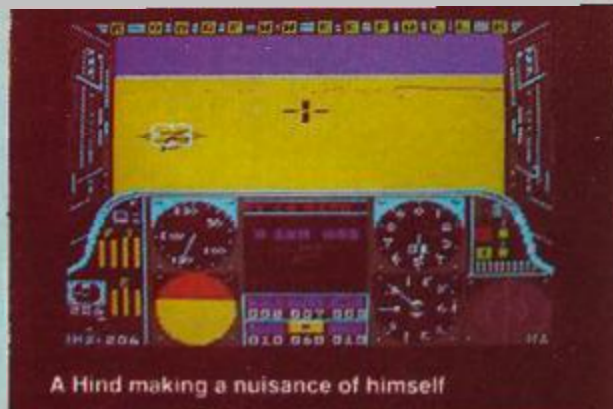

A Hind making a nuisance of himself



I'm hit! How bad?

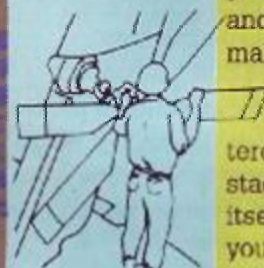
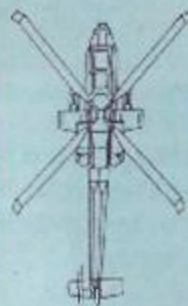

And there are even more options: easy or realistic settings on flying, landing and weather; choice of opposition – **third line yokels, second line reserve and front line shock troops**; and equipment quality – such as missiles and guns – depending on troop quality.

Once you have chosen your mission you are given a briefing listing your primary and secondary objectives. These are targets that must be destroyed no matter how many others you hit. Intelligence information on troop and equipment quality is available, as well as a sick call option to chicken out.

After that you choose your weapons. The weight limit of the Apache is limited according to the weather. Make sure you leave enough for fuel!

Not so long ago the graphics on *Gunship* would be described as brilliant, and even after the Freespace system used in *Driller* and *Darkside* they still rate very good. Not only is there a true filled in view through the cockpit window, but you can move this view around to see what's to the side and behind you. Occasionally, however, transparent hills mar this effect.

The sound is average, with a rotor racket that gets right under your skin. But enemy missile and radar lock on is announced by sound – a nice touch. Above all, you know when you're hit, 'cos the explosions are great.

The most important skill in flying is balance. If you can balance the cyclic and collective controls, making sure the Apache's nose is pointing just so, then you've mastered flying. Getting to that stage is a challenge in itself. When you're there you can start to fathom combat flying and gunnery.

Gunship is the simulator: nothing else comes close. I do feel, though, that the CPC implementation is not fully complete. Do the Warsaw Pact really paint their vehicles bright blue? And how come some can't be attacked, for no good reason? Then there's the hills, which appear so solid and then fade away for a few seconds. Worst of all, in the box, along with the excellent manual, there's a little card telling you what's missing on the CPC version. For £15 or £20 you expect features to be added: what you don't expect is a cut-down conversion.

Vietnam is not referred to anywhere in the manual's text. Could this be anything to do with recent history, I wonder? Just a thought... PbM

First Day Target: Survive in 'South East Asia'

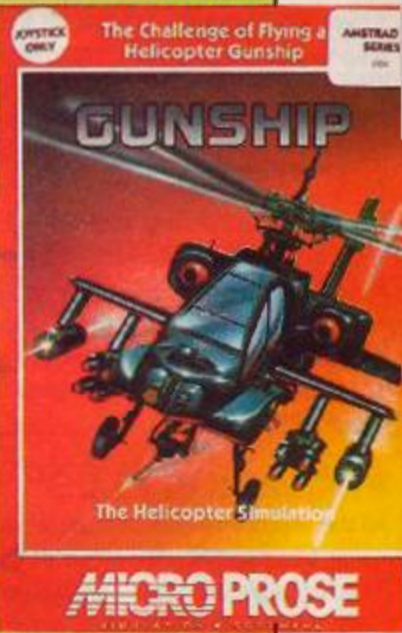

The Verdict

GRAPHICS86%

- True perspective in three dimensions.
- Occasional glitches and wipeouts irritate.

SONICS61%

- Rotors sound like sewing machines.
- Great explosions and warning noises.

GRAB FACTOR64%

- Tricky to fly around.
- Strong urge to explore.

STAYING POWER94%

- Lots of challenges.
- You can only ever improve.

AA RATING82%

- Too expensive to be Mastergame.

Missions are easily changed. The first variable is the pilot, who can be replaced by a lowly sergeant. Pilots can also be loaded and saved. The second variable is the campaign. Next comes mission difficulty – **regular, volunteer and volunteer hazardous duty**.

What you don't get for your £20

The Microprose manual for *Gunship* is quite brilliant. It's 80-odd pages of lavish, well written and beautifully illustrated material that assists greatly in the simulation illusion.

Only thing is, it ain't for the Amstrad. After the superb manual you discover a single plain piece of card which outlines some of what you don't get for your £20 (it's not even complete). Such as:

1. No roster of pilots – only one at a time
2. Amstrad version does not give primary and secondary target locations in mission briefing
3. Accelerated time is not included
4. Abort mission is not included
5. The enemy appears as only one colour on the radar screen
6. Vehicle identification is not included

PROTEXT Grows!

New MAXAM rom

PROTEXT FILER - New Release!

This invaluable program will keep your address lists or other datafiles in good order. Includes: datafile management from within Protex; extremely flexible file sorting program; label printing and mailmerging using the datafiles. Send SAE for full details.

disc: £24.95

PROTEXT OFFICE - New Release!

Invoice printing program as used by Arnor. Easily configurable for your own requirements. Works from within Protex. Produces invoices/credit notes/delivery notes/statements. Includes Protex Filer. Send SAE for full details.

disc: £34.95

PROTEXT

Protex is without doubt the most sophisticated word processor you'll find on any home micro. Its ease of use and advanced range of features are normally only found in business systems costing many times more. Widely praised throughout the Amstrad press, Protex is rightly acclaimed as the No.1 word processor for Amstrad CPC owners.

- * Super fast * Works with any printer * Flexible find and replace *
- * Layout stored with text; normal & decimal tabs, left & right margins *
- * Word count * Versatile print options; incl. headers/footers, page nos. *
- "Extremely powerful editing features ... superb search and replace" AA
- "I can't emphasise how good it is" PCW

rom: £39.95, disc: £26.95, cassette: £19.95

PROSPELL

Typing and spelling errors are simple to make and frustrating to miss. But by using Prospell, you can produce documents that are error-free. Prospell is an spelling checker that points out any odd words or dubious spellings.

- * checks Protex text in memory *
- * checks file on disc from Protex/Tasword/Amword/NewWord/WordStar *
- * over 33000 words * room for thousands more of your own *
- * up to 2000 words/min * find words and anagrams - great for crosswords *
- "Fast, efficient, easy to use" YC

rom: £34.95, disc: £24.95

PROMERGE

More than just simple mail merging for multiple standard letters!

- * integrates perfectly with Protex * read data from keyboard or file *
- * conditional printing so you can create your own personalised letters *
- * use the built in maths functions to produce invoices etc *
- * microspacing - to even out the spaces between words * typewriter mode *
- * link files together at print time * Reformat while printing *

disc: £24.95

PROMERGE PLUS

All the features of Promerge, plus:

- * Edit two separate files in memory at once; copy blocks between them *
- * Background printing - allows you to print and edit at the same time *
- * Box mode - cut and paste any rectangle to create newspaper columns *
- "You'll have a set-up that can thrash any 8-bit word processor for speed...and even some 16-bit programs for power" PCW

rom: £34.95

ROMBO

All rom software requires a rom expansion system. Its benefits include zero loading time and maximum memory available for text, data, programs etc. Remember; Utopia and the extra commands of Promerge Plus are not available on disc. Fits CPC464/664,6128.

8 socket rom box: £34.95

Amster's Cage Rom: £31.95

Quite simply the best Viewdata rom available ... ideal for Prestel. Menus. Easy to use. Can be used to upgrade your existing comms software rom. Please state which serial interface you have.

MAXAM 1½ - New Release!

At last, due to massive public demand, we have produced an enhanced Maxam ROM especially for Protex users. The editor has been taken out, and you can now assemble your source code simply by typing ASM while it is in Protex's memory. Debugging is now easier with comprehensive diagnostics and the ability to change register contents and resume from breakpoints. Other new features include load/save machine code from Protex/Maxam and extra assembler directives. All the other Maxam features are included.

rom: £29.95

MAXAM

The classic Assembler/Monitor/Editor for developing Z80 machine code.

- * Plain English error messages * Disassembler * Memory editor *
- * Menu driven full screen editor * load/merge/save/print/find/replace *
- * Mix BASIC and machine code * or assemble directly from editor *
- * Use the editor to edit BASIC programs saved in ASCII *

"This piece of software should be held up as an example of what can be done by programmers who care ... buy one now!" E & C
rom: £39.95, disc: £26.95, cassette: £19.95

BCPL - new low price!

Flexible, fast, easy to learn programming language. Comprehensive I/O libraries including graphics and sound. Example source files supplied, including a space invaders game, full screen editor and all the libraries. 60 page manual covers the language and gives details of the libraries.

"Designed for humans, not computers" CWTA

rom: £29.95, disc: £24.95

UTOPIA

50 new commands available without having to load a program, including:

- * Text screen dump * Graphics screen dump to Epson compatible printer *
- * disc utilities - disc format, disc copy, copy files, sector editor *
- * useful function keys automatically set up; easily define your own *
- * BASIC programming utilities * ROM management commands *
- "UTOPIA is by far the best utilities rom...it's worth buying a rom board just to plug it in" AMSCLUB
- "Utopia seems to be in a class of its own" AMTIX

rom: £29.95

C (6128,CP/M+)

Integrated C programming system. Full implementation of K&R standard.

- * Floating point * 32 and 16 bit arithmetic * Optimising compiler *
- * Linker * I/O and maths libraries * Conditional compilation * Macros *
- * Editor is program mode of Protex *

"In typical Arnor fashion, they've taken their time and got it right" AU
disc: £49.95, Maxam II + C: £69.95

MAXAM II (6128,CP/M+)

Enhanced version of Maxam for CP/M+. Extras include:

- * Single stepping * conditional breakpoints * symbolic debugger *
- * Editor is program mode of Protex * Macro assembler *
- "Now the best gets even better" CWTA CPC

disc: £49.95, Maxam II + C: £69.95

PROTEXT (6128,CP/M+)

Combines all the features of Protex, Promerge Plus and Prospell into one integrated program. German program & dictionary also available (Prowort).
"Protex is just so fast and versatile once you have used it - it is like putting Nigel Mansell against a C5" PYATW
disc: £59.95

Also:	Model Universe (CPC)	£19.95 (disc), 15.95 (tape)
	Pocket Protex (CP/M+)	£29.95 (limited period only)
	PC Protex	£59.95 (5¼" or 3½" disc)
	Atari ST Protex	£79.95

Releasing your Amstrad's potential ...

Arnor, Protex House, Wainman Road, Peterborough PE2 0BU. Tel: (0733) 239011 (24 hr)

All prices include VAT, postage and packing. Access/Visa/Cheque/Postal order. Please mention this magazine when ordering.



DREAM WARRIOR

US Gold ● £9.99 cass, £14.99 disk
joystick/keys

The world of the future is controlled by huge corporations under the dominion of the Focus Fellowship. Little is known of Focus's activities except that they can send dream demons into the mind of anyone who opposes them and make them go insane. Four people, the Asmen, discovered a way to combat the dream demons, but unfortunately three of them were dragged in dreams by the demons where they are now slowly going mad. You are the last Asman and must rescue your comrades.

SECOND OPINION

"Graphics are quite nice, the gameplay is fun. Playing it for a while show up the deficiencies such as naff animation and occasional droughts of safe cards which mean a slow, lingering death."

"The idea is quite good and it's just a shame it wasn't taken a bit further. Not enough game here."

PbM

GREEN SCREEN: No complaints

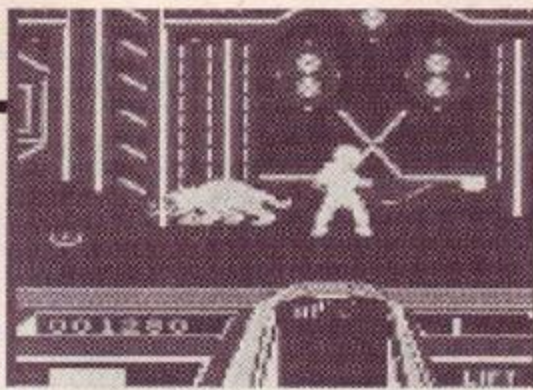

● Beware of the demon

A horizontally scrolling playing area covers most of the screen and a panel at the bottom indicates your **depth of sleep, score, card carried** and a picture of the

The Verdict

GRAPHICS58%

- Smooth horizontal scrolling.
- Just a touch too much blue.

SONICS24%

- Needs more effort.

GRAB FACTOR57%

- Nearly always something to do.

STAYING POWER48%

- It'll take a long time to complete...
- Waiting for the right globe to come along is frustrating.

AA RATING51%

- Arguably not game of the year.

dreamer. If your depth of sleep meter reaches zero then you wake and the game is over.

Everything you need to rescue the dreamers is in the dream, but so are the hazards to prevent you. Four types of globe drift about and when shot they deposit their contents. The four colours each contain a different thing: blue have bits of the dreamer's psychic image, green have energy for the dream hopper, red contain safe access cards and grey have lift access cards.

A safe contains deep sleep draughts so that you stay asleep longer and lifts allow travel between levels. The dream hopper allows movement from dream to dream. To complete a dream you must collect all the pieces of psychic image for the dreamer and when all three dreamers are free you can look for the doorway to the most dangerous dream demon, **Ocular.**

Scrolling is smooth and fast. The graphics are perhaps a little too blue, but the sprites move well and the Asman is animated very well. Sounds effects are almost non-existent and tunes are played silently.

Collecting bits of dreamer is time consuming and leads to boredom. It's just a matter of shoot the globe, collect the blob and repeat until your mind shuts down. Sleep well.

GBH

FIRST DAY TARGET

Free a dreamer

BUBBLE GHOST

Infogrames ● £9.95 cass, £14.95 disk
joystick/keys

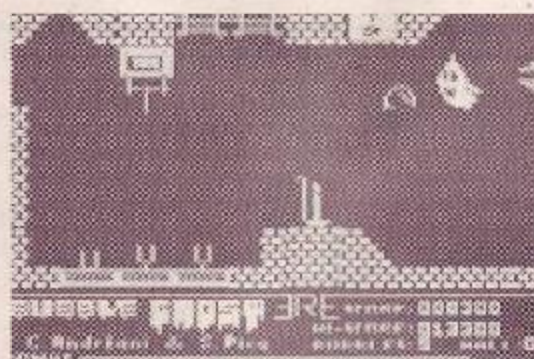

● I'm forever blowing bubbles

You may think being a ghost is just a matter of drifting around wearing a sheet and saying boo, but you'd be wrong. The star of this spooky story, a poor unfortunate ectoplasmic being, has lost his soul. He knows where it is - in a bubble - and he wants it back. To become whole again he must guide his bubble through the castle.

The castle is made up of a multitude of interconnecting rooms, each filled with hazards. Nothing worries the ghost - he can pass straight through anything without a worry - but the bubble is much more sensitive about things and bursts

when it touches anything that isn't the ghost. Moving a bubble when you have no body is not easy. You have to blow it everywhere.

Each room is made up of lots of sharp objects just waiting to pop your bubble: knives, spikes, candles, disembodied heads and even the walls. Electric fans blow the bubble off onto a spiky bit.

Surprisingly for an Infogrames game there's no music, but the sound effects are good. The background graphics are simple and the sprites are flickery, but there are some humorous effects: when the bubble bursts the ghost looks most annoyed.

This is a simple game in concept that's mindbogglingly frustrating and also

immensely addictive. It'll wear off, but you'll get a few hours of enjoyment.

GBH

FIRST DAY TARGET

Complete 10 screens

The Verdict

GRAPHICS54%

- Some humorous touches to the graphics.
- Flickery sprites.

SONICS35%

- Effects are fine, but there aren't many.

GRAB FACTOR68%

- A nice idea that works well.
- Some early rooms are too difficult and stop the enjoyment.

STAYING POWER56%

- Large castle to explore.
- May tire of it if you keep getting stuck in the same room.

AA RATING61%

- A fun game unfortunately spoiled a little by flickery graphics.

SECOND OPINION

"I've always liked CPC games that originate in France. They seem to have a style you just don't find anywhere else - which is not necessarily to say they're any better."

Bubble Ghost has an original theme, goodish graphics and fiendishly tricky gameplay. For a while you think you've cracked it only to fail on a new screen. Good Stuff.

PbM

GREEN SCREEN: No problem

ATV SIMULATOR

Code Masters ● £1.99 cass
joystick/keys

All Terrain Vehicles (ATV's) are tractors, more or less, that can travel over just about any kind of terrain. *ATV Simulator* is either a simultaneous two player or single player game set over a series of courses of increasing difficulty.

The screen is split across the middle: one half for each player with a score panel to the right and a clock below the playing area. Your ATV sits in the centre of horizontally scrolling playing area.

Your objective is to reach the end of the stage before the timer reaches the preset time limit. Succeed and you go onto the next course; fail and it's game over.



● Two player action

ACTION FORCE

Virgin ● £8.95 cass, £14.95 disk
joystick/keys

You're Wild Bill, pilot of the *Dragonfly* helicopter and you have a mission: to ensure the safe arrival of the *A.W.E. Striker* at its destination. The *Striker*, though, has two problems: it bumps into things and it falls down holes, and neither is very good for it. There are also lots of nasty *Cobra* forces out there just waiting to blast anything into little pieces.

Across the bottom of the screen, where your score is shown, is a status panel informing you of the condition of the *Dragonfly* and the *Striker*. In the upper part is the horizontally scrolling playing which is centered around your helicopter.

There are several levels to the game, each more difficult than the last, but still very similar in style of play. Strewn about the landscape are holes that must be bridged and barriers to be destroyed so that the *Striker* can exit at the end of the level. Fortunately there are sections of

● The *Dragonfly* hovers menacingly



SECOND OPINION

"Hm, I wonder... Gary suspects this is too easy, but I'm not so sure. Obviously with a budget game many people who buy ATV are likely to be at school rather than college or at work - many, I said, not all! - and it may well be the case that they find the much-vaunted Code Masters 'playability' about right for them.

Besides, what's easy for one person (in this case someone who plays games constantly) may not be easy for another. What do you think?" SC

GREEN SCREEN: OK

The first two courses are 'Sand Duning' and 'Grass Trakin', neither of which are particularly difficult to complete. 'Icebergs' is the third one and things begin to get tougher from here onwards with 'Pyramids' very hard to complete.

Sound effects are basically engine noises and collisions, but you do get a pretty good tune on the title screen. The horizontal scrolling is smooth and fast. The sprites are only in two colours and not particularly colourful and scenery is likewise lacking in colour.

SECOND OPINION

"The combination of inter-game messages and one-life games is not a good one. Inevitably with a new game you take time to get to know your way about, and to be held back like this - especially in a game that moves so fast - is very frustrating.

Still, you soon improve, after which things pick up. A bit." SC

GREEN SCREEN: No complaints

bridges covering some of the holes, but even so there are more holes than bridges. You therefore have to carry bridge sections from place to place and make sure the *Striker* gets through. Any barriers that you come across must be shot to pieces or bang goes the *Striker*. That's about it: you hurtle around blasting enemies and protecting the *Striker*.

Considering the speed at which the landscape scrolls it's still remarkably fast. It's a pity as much effort wasn't put into the graphics as was put into the scrolling - they're lacking in both detail and colour. Sound is just a handful of effects and there are no tunes.

Action Force is one of those games that's frustrating, but for the wrong reasons. Level two is incredibly tight on timing to destroy the first obstacle before the *Striker* gets to it and that tends to annoy

The Verdict

GRAPHICS	56%
<input type="checkbox"/> Smooth horizontal scrolling, even in two player mode.	
<input checked="" type="checkbox"/> Colour could have been used better.	
SONICS	63%
<input type="checkbox"/> Good music on the title screen.	
GRAB FACTOR	66%
<input type="checkbox"/> Two player action adds to the fun.	
<input checked="" type="checkbox"/> Possibly too easy to begin with.	
STAYING POWER	52%
<input type="checkbox"/> Courses increase in difficulty...	
<input checked="" type="checkbox"/> but they do so in jumps rather than steps.	
AA RATING	63%
<input type="checkbox"/> Worth a look.	

As with most of the Code Masters stuff it's not brilliant, but not appalling either. Good fun to start with, but perhaps a little lacking in depth and sophistication over the long term. GBH

FIRST DAY TARGET
Complete 'Icebergs'

rather than make you play again. At the start of the game and between levels a message squelches onto the screen at an yawfully slow rate. They're interesting the first time, but in the middle of a game the last thing that you want is a tedious delay before you go to next bit. £9 is lot to ask for this sort of thing. GBH

FIRST DAY TARGET
Complete level two

The Verdict

GRAPHICS	49%
<input type="checkbox"/> Excellent scrolling that's both fast and smooth.	
<input checked="" type="checkbox"/> Ineffective use of colour.	
SONICS	23%
<input checked="" type="checkbox"/> Feeble sound effects.	
GRAB FACTOR	45%
<input checked="" type="checkbox"/> Infuriatingly difficult on level two.	
<input checked="" type="checkbox"/> Inter-level messages are tedious and superfluous.	
STAYING POWER	51%
<input type="checkbox"/> It should take a long time to complete all of the levels.	
<input checked="" type="checkbox"/> Only one life? Unplayable.	
AA RATING	46%
<input checked="" type="checkbox"/> Not a bad idea - just badly executed.	

OVERLANDER

Elite ● £9.99 cass, £14.99 disk
joystick/keys

Take one nice green planet, remove the ozone layer and what do you get? A desert world where the population is forced to live in huge underground cities so that they're not exposed to the lethal solar radiation. The only people who travel from city to city are the Overlanders, who drive around in custom built cars and travel between cities for fun.

A dashboard occupies the lower third of the screen and the rest is taken up with the road. Information on your weapons systems, speed and fuel is shown on the dashboard and the road has a view of your car from the rear as well as any badguys or obstacles in your way.

Your car can be equipped with a wide range of equipment to help in arriving at your destination. They include missiles, bulletproofing, turbo chargers and so on. All cost, and some are very expensive.

With your car equipped you set off for your destination and then you encounter the Surface Dwellers. They live to kill, and Overlanders are the only thing that they can get. Surface Dwellers are split

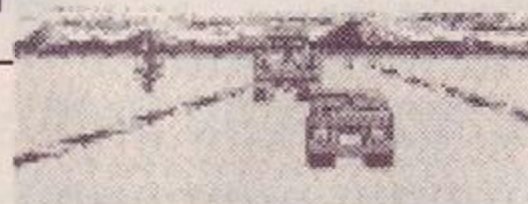

into gangs that employ various tactics to destroy you. Kamikazee's (their spelling) are suicidal motorcyclists; roadhogs try to push you off the road; crawlers use shot gun emplacements and wrecked cars and offroaders are heavily armed and drive armoured trucks.

The graphics are lacking in colour, but the 3D perspective road moves quite smoothly and quickly towards you. There are no tunes in the game, though there's an excellent one on the title screen. Sound effects are abundant and serve their purpose.

At first it just looks like *Outrun* without the colour, but with speed. After extended play, however, you discover an

SECOND OPINION

"From an objective standpoint this game has little content, but you try avoiding a cherry blossom biker at 160 kph. I'll be coming back to this game after I've got over the nervous breakdown caused by frustration."

PbM

GREEN SCREEN: A little trickier than colour, but still OK.

MARAUDER

Hewson ● £9.99 cass, £14.99 disk
joystick/keys

Long, long ago the Jewels of Ozymandius were stolen by a cruel and despotic civilisation and buried deep beneath the surface of the planet Mergatron. You need to recover the jewels and in your Marauder Battlecar arrive on the planet, which is protected by an ancient defence.

An aerial view of the scrolling playing area shows your car and its surroundings. A panel below shows your lives, smart bombs and any messages that appear.

Then there's the weapon beacons which flash through red, yellow, cyan, blue, purple and green. Red, yellow and cyan are beneficial: they give you an extra

SECOND OPINION

"A curiosity, this: it's a poorish game by Hewson's high standards, yet it would be a blockbuster for many others."

Yet another vertical scrolling shoot-em-up, but one requiring thought as well as fast coordination."

PbM

GREEN SCREEN: All clear

smart bomb, shields and a bonus life respectively. Shields makes you invulnerable for 10 seconds and the smart bombs blow away everything on screen. Blue, purple and green are harmful: control reversal, lose a life and laser jammed are the consequences.

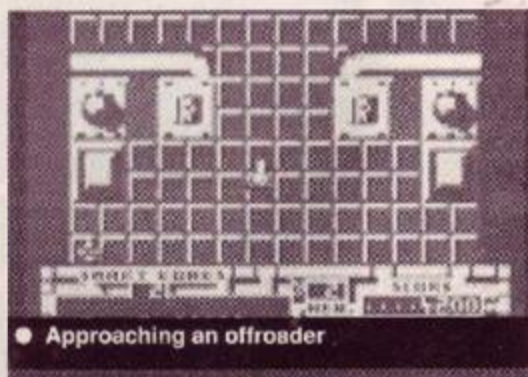

● Approaching an offroader

The graphics are well drawn, colour is well used and the scrolling is very smooth. An excellent tune plays on the title screen and another even better one plays throughout the game. If you prefer sound effects then you can turn the tune off and have them instead.

First impressions of just another shoot-em-up with pretty graphics disappear after a few games. The weapon beacons, essential to solving the game, make a difference. Just going for extra lives is not a good idea, and there are times when the only way out is to use a smart bomb. In some ways it's like *Highway Encounter*, with problems to be solved, hazards to be

The Verdict

GRAPHICS 56%

- Road moves smoothly towards you.
- Lacking in colour.

SONICS 59%

- Great title tune.

GRAB FACTOR 64%

- Gratuitously blasting away at things is fun.
- Kamikaze bikers are very annoying.

STAYING POWER 58%

- First route is just a little too tricky to complete.
- Plenty of routes to complete in a quest for the high score.

AA RATING 81%

- Not mind blowing stuff, but fun.

element of strategy involved in deciding which weapons to arm yourself with and which cargo to choose. Not brilliant, but definitely not awful either. **GBH**

FIRST DAY TARGET

Complete the first mission

avoided and bad guys to blast. It has a similar addictive quality that keeps you wanting to play just once more. And the music is brilliant. **GBH**

FIRST DAY TARGET

Complete zone 1

The Verdict

GRAPHICS 78%

- Excellent use of colour.
- Smooth vertical scrolling.

SONICS 84%

- Fantastic title tune...
- And an even better one in play.

GRAB FACTOR 76%

- Immensely addictive.
- Very frustrating, until you learn your way around.

STAYING POWER 72%

- Completing one level is tough enough.
- Annoying when you're sent a long way back because you lost a life.

AA RATING 73%

- A very good game...
- but Hewson are capable of more.

BIONIC COMMANDO

Go ● £9.99 cass, £14.99 disk
joystick/keys

Once upon a time there was a nice little planet inhabited by happy people. One day some aliens come along and lay waste to the planet. Ten years pass and the aliens manage to create a doomsday weapon to erase humankind from the planet forever. The doomsday missile must be deactivated and only the elite unit of bionic commandos can do the job.

You are the green and black figure trying to avoid or kill the green and black figures hiding in the green and black scenery. The green and black screen scrolls in four directions as you try and reach the end of the stage. There are five stages: the dying forest, the castle, infil-

SECOND OPINION

"Bionic Commando - the first game for the colour-blind! Sarcasm apart, the game does have a certain quality and I found myself playing it quite a lot. I daresay that over the medium term (next Wednesday) I'll lose interest."

PbM

COLOUR SCREEN: All green

tration, the control room and the silo.

Each stage is made up of many inter-connecting platforms and is swarming with enemy troops. Some areas are also mined and occupied by bees with a stinging tendency. Later levels have cannon, suicide troops and giant robots that all have the same idea: to kill you. Movement

The Verdict

GRAPHICS24%

- Animation is done fairly well.
- Where has all the colour gone?

SONICS26%

- Bang.

GRAB FACTOR45%

- Doing tarzan impression while hanging by an extended arm is the most enjoyable part of the game.
- Frustrating when you die in an unavoidable situation.

STAYING POWER36%

- Stages are difficult, but not impossible to complete.

AA RATING39%

- On the one hand you get *Heroes of the Lance* and on the other you get THIS!



Where am I?

between platforms is achieved by extending your bionic arm towards the platform in question and then pulling yourself up.

Anyone with a colour monitor will instantly think that there's something wrong with it, but they'll be wrong because the game really is in green and black. In subsequent stages the two colours change, but it's still bad having only two colours. The graphics in general are poor and the scrolling leaves much to be desired. Sound is just a mixture of crude explosions and shooting effects.

There have been games in the past looking distinctly like a straight port from another Z80 based computer that shall remain nameless. This one in particular looks terrible. Graphics like this should have died out years ago and the gameplay leaves a lot to be desired too.

GBH

FIRST DAY TARGET

Complete stage two

URIDIUM

Hewson ● £1.99 cass
joystick/keys

The solar system, you'll no doubt be surprised to find, is under attack yet again. Some little aliens have placed huge dreadnoughts around the fifteen planets in your corner of the galaxy. Mineral resources are being drained from the core of the planets, and this is considered naughty by the populations of the worlds. Some heroic person must get up there and stop them and you're the one to do it.

You climb into the seat of your Manta class space fighter and head for the first of the dreadnoughts. Each dreadnought is one screen high and several wide. As you fly across the surface of the huge ship it scrolls horizontally beneath you. Aliens

SECOND OPINION

"I found the homers made this a very difficult game, but fortunately Uridium has that elusive quality that makes you come back to it again and again."

PbM

GREEN SCREEN: No problem

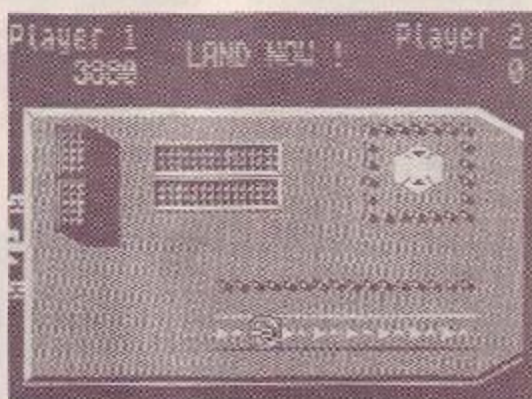

Your Manta flies across the surface of a dreadnought

sweep in from both sides of the screen to destroy anyone coming too near.

To knock out a dreadnought you have first to destroy the aliens flying across its surface and blast any ground targets that you come across. Take care with the meteor shields and communications aerials, though, because your ship explodes on impact. When everything has been blasted a 'land now' message appears and you just touch down to gain loads of points and go to the next dreadnought.

There's not much colour: everything's in two colours, but they do change from level to level. The graphics are detailed and the horizontal scrolling fast. A wonderful tune plays on the title screen and the sound effects are pretty good too.

The plot may not be very sophisticated - you fly around and blast away at things - but there is a certain element of satisfaction when you destroy a dreadnought. Great value for money.

GBH

FIRST DAY TARGET

Destroy three dreadnoughts

The Verdict

GRAPHICS57%

- Fast horizontal scrolling.
- Colour could have been used more.

SONICS56%

- Brilliant title tune.
- Adequate effects.

GRAB FACTOR58%

- Plenty to blast and a little to think about.
- Frustrating having to completely restart a level when your ship is destroyed.

STAYING POWER54%

- Fifteen dreadnoughts to destroy.

AA RATING68%

- Good old fashioned shoot-em-up.

ROMANTIC ROBOT

present

1988 - THE YEAR OF THE ROBOT

RESET

Multiface two

STOP

If you wish to be able to STOP any program at any time and COPY it to disk or tape, fully automatically, at a touch of a button, then MULTIFACE 2+ is the ONLY answer. There are no other comparable hardware devices, and the software copiers simply cannot compete.

Firstly you cannot compare the SUCCESS ratio of any tape copier with the MULTIFACE - you get what you pay for (and we throw in a lot more with the MULTIFACE . . .).

TAPE COPIERS always need to be loaded first, whilst MULTIFACE has all software in ROM for instant use. TAPE COPIERS can only attempt to copy a program as it stands, before it loads - there are various protections in the way and not enough memory for both the program to be copied and the copier. MULTIFACE is different: you can load any program from TAPE or DISK, run it as you wish and activate the MULTIFACE whenever you need it. Once you SAVE a program, be it to DISK or TAPE, you can CONTINUE it, SAVE it again if you wish, etc. In fact, you can play games as never before: there is no need to start from the beginning each time you play a game (as you would with a tape copier - if it could copy in the first place . . .). Since you can SAVE a program at ANY TIME and continue it, you can actually SAVE as you progress through a game. If, eventually, you lose all your lives, you can just load the latest saved version and continue from there! That is, if you do not manage to get INFINITE LIVES to start with: MULTIFACE has a built-in TOOLKIT which allows you to STUDY and ALTER anything in any program; you can thus POKE in infinite lives, ammo, etc.

MULTIFACE is extremely simple to use, friendly, idiot-proof, menu-driven with on-screen instructions, fully automatic - PURE MAGIC. It can be used on any CPC, comes with a cable and an extension bus for £47.95 ONLY! By the time you buy 10 programs on tape instead of disk - MULTIFACE will put them on disk for you - you will have saved some £50 which is more than the cost of a MULTIFACE. The money you save on further tapes is all yours!

MULTIFACE - WORTH EVERY PENNY, SAVES YOU POUNDS!

NOW AVAILABLE: MULTIFACE 2 PLUS - THE INVISIBLE ONE.

Tape-to-disk at the touch of a button. Ridiculous, you may say, but it works every time. Multiface can stop any program in its tracks and save the program from memory to either tape or disk. It's completely fool-proof. Similar products have had problems with screen size, colour and even sound; Multiface can handle all these without a second thought!

That alone would have satisfied many people, but Romantic Robot has gone one step further, incorporating a memory editor. No program is safe with this: everything is out in the open, including the Z80 registers, CRTC data and any part of memory.

Don't be fooled into thinking this will result in mass piracy, however. The Multiface unit itself must be plugged into your Amstrad to allow reloading of a program it saved.

Multiface II must be the cleverest hardware device at present - a necessity for disk owners who thought they were stuck with loading from tape every time.

AMSTRAD ACTION JANUARY 1987

WOULD YOU LIKE TO TURN YOUR CPC INTO A PROFESSIONAL SET-UP?

Would you like to be able to attach additional disk drives - 40/80 track, single/double sided, 5.25 or 3.5 or 3 inch - and store up to 800K per disk? All controlled by a powerful DOS? Have RANDOM ACCESS to your files? Get a PRINTER BUFFER and SILICON DISK and a ROM manager and over 50 new bar commands! All this on a single ROM:

RODOS

FOR ANY CPC ONLY
£29.95



Now also available: RODOS EXTRA on disk for only £9.95. Any RODOS owner will find RODOS EXTRA indispensable: it offers nearly 200K of valuable information how to get the most out of RODOS, with examples of RODOS applications ranging from simple to complex such as a DISK DOCTOR or IBM MSDOS DISK READER. The indispensable EXTRA!

RODOS requires a ROMBOARD. RODOS EXTRA needs RODOS. INSIDER needs MULTIFACE 2.

TOP SECRET

BUT NOT FOR THE INSIDER

NO PROGRAM IS SAFE ONCE THE INSIDER GETS IN!

JUST INSTALL INSIDER INTO MULTIFACE, RUN ANY PROGRAM, STOP IT AT ANY MOMENT AND INSIDER REVEALS EVERYTHING: IT WILL FULLY DISASSEMBLE, FIND TEXT OR CODE, VIEW/ALTER MEMORY AND Z80 REGISTERS, DUMP TO PRINTER - ALL THIS ON DISK FOR **ONLY £14.95**

INVALUABLE FOR M/CODE USERS
SOLID GOLD FOR HACKERS.



THE YEAR OF THE ROBOT - BE PART OF IT

I Order: MULTIFACE 2 £47.95 RODOS £29.95 Plus p&p UK £1, EUROPE £2
INSIDER £14.95 RODOS EXTRA £9.95 Overseas £3

I enclose a cheque PO for £..... or debit my No Card exp.....

Name & address

ROMANTIC ROBOT UK LTD

54 Deanscroft Ave, London NW9 8EN



24 hrs



01-200 8870



!! NOW SPEEDTRANS PLUS HAS EVEN MORE TO OFFER !!

SPEEDTRANS PLUS2

For CPC6128 (or 464/664 with DK Tronics 64K (or larger) Memory)
Once the programs has been transferred to disc IT WILL RUN ON ANY CPC.

SPEEDTRANS PLUS2 now handles the VERY LATEST Speedlock types automatically. No need to hold a key down at anytime during loading. **SPEEDTRANS PLUS2** also saves 99% of opening screens and saves them in their full colours

FULLY AUTOMATIC - JUST ONE KEYPRESS * ONLY ONE PROGRAM TO RUN WHICH FINDS THE SPEEDLOCK TYPE AUTOMATICALLY * WILL TRANSFER ORIGINAL AND MANY OF TODAY'S SPEEDLOCK PROGRAMS * NO FIDDLING OR MEDDLING - WRITTEN WITH THE AMATEUR IN MIND * AUTOMATIC DISC FILENAMES * NO WASTED DISC SPACE - SAVES THE CORRECT AMOUNT OF GAME CODE * SAVES 99% OF OPENING SCREENS * SCREENS SAVED IN THEIR CORRECT COLOURS * COMPRESSES SCREEN CODE TO SAVE EVEN MORE DISC SPACE * FASTER LOADING TIMES FROM DISC BECAUSE OF SHORTER FILE LENGTHS

SPEEDTRANS PLUS2 transfers over 200 programs to Disc, some of the latest it will do are MADBALLS, FREDDY HARDEST (both games), BASKET MASTER, MATCHDAY II, PHANTOM CLUB, GRYZOR (main program), SUPER HANG ON.

These latest Speedlock types can be identified by the whole screen flashing with horizontal bands of colour immediately after the first file has loaded. Do remember that **SPEEDTRANS PLUS2** does not save all the memory in the hope of having saved all the game. It saves exactly the right length of code. All screens are saved in compressed form - some as little as 4K (Basket Master) - thus saving even more disc space.

SPEEDTRANS PLUS2 is the most sophisticated Tape-to-Disc transfer utility for SPEEDLOCK protected programs ever published. It will certainly transfer more games than any other Speedlock transfer program on the market and with much greater ease. Other transfer programs require you to know how long the game code is so that you may run an alternative program for the long games which does not save the loading screen. This is done because they do not make use of the extra memory available on the CPC 6128 or from the use of an extra RAMPACK (DK Tronics 64K or greater.) This program is highly intelligent in that it first reads the loader from the tape and establishes which type of protection is in use from 6 alternatives. At the end of the load it then finds out how long the code is and if it is too long to be saved to one file it will move the excess code into the banked memory and save the game in two parts and write the appropriate loader program. The screen will also be moved into a bank and compressed before saving. This can mean screen files as small as 4k (Basket Master) depending on mode and content. All this adds up to a lot less disc space being used than with other transfer programs and you will nearly always get the loading screen saved. The exception to this is when there is no loading screen (as in SCRABBLE) or when the screen is blanked out and more code is loaded into the screen memory, as in BMX SIMULATOR and MADBALLS for example. Try getting a screen with Multiface or any other imager. These imagers are only capable of saving what you have in memory at the time the button is pressed. What happens in multi part games? you have to press the button for each part thus wasting precious disc space. They also save far too much code and therefore waste even more space and saving too much code means longer loading times from disc. Programmers are now checking to see if you have an imager plugged in and if you have the program will not load. Imagery also have to be in place before you can reload your program and saved programs can only be reloaded in to the machine in which they are saved. **SPEEDTRANS PLUS2** creates totally stand-alone files and if you have no other CPC even without extra memory they will run perfectly. It also displays the saving name on screen at the start of the load with all except the very latest games. In all cases the disc saving name is displayed while the save is carried out. To run the transferred game just RUN this name. Another intelligent feature of **SPEEDTRANS2** is that the very first thing it does is to find out which drive it is in. This means that if you have a two drive system you may run the program from drive B by typing RUN "B.DISC" or "B:RUN"DISC. However the saving will ALWAYS be to DRIVE A so with a single drive you must change the disc when prompted on screen.

DISC:- UK £14.99 - EUROPE £16.25 - REST OF WORLD £17.00

Upgrade your **SPEEDTRANS PLUS** - send your disc together with: UK £2.00 - EUROPE £3.25 - REST OF WORLD £4.00
Upgrade your **SPEEDTRANS TAPE** send your tape together with: UK £12.00 - EUROPE £13.25 - REST OF WORLD £14.00

*** LOW LOW PRICES * ARNOR SOFTWARE * LOW LOW PRICES ***

Program	UK - Disc		Europe - Disc		Rest of World - Disc	
	Disc	Eprom	Disc	Eprom	Disc	Eprom
PROTEXT OFFICE * NEW *	29.50	N/A	30.75	N/A	31.50	N/A
PROTEXT FILER * NEW *	19.50	N/A	20.75	N/A	21.50	N/A
PROTEXT	21.50	34.50	22.75	35.75	23.50	36.50
PROSPELL	19.50	29.50	20.75	30.75	21.50	31.50
PROMERGE (ROM=PROMERGE PLUS)	19.50	29.50	20.75	30.75	21.50	31.50
MAXAM * THE BEST! *	21.50	34.50	22.75	35.75	23.50	36.50
MAXAM 1 1/2 * NEW *	N/A	24.50	N/A	25.75	N/A	26.50
UTOPIA	N/A	24.50	N/A	25.75	N/A	26.50

Purchase the Rombo romboard and we will give you a further £3.50 discount on each rom program

ROMBO ROMBOARD UK - £31.00 EUROPE - £33.00 REST OF THE WORLD - £35.00

DMP 2000/2160/3000/3160

The printer buffer presently in the DMP 200/3000 series is a 2K RAM. Most of this RAM is used by the printer's operating system leaving an average 1/2K as buffer space. Our upgrade kit contains a new static RAM chip which will increase the printer buffer by 6K (about 4 pages of text). This upgrade allows all Download Characters to be re-defined allowing the user to design special characters for use with scientific and other programs. The kit is supplied with full pictorial instructions to allow the amateur to carry out his own modification (the DMP2160 takes about 7 minutes). If you don't think you are up to it your local TV shop can do the job in approximately 15 minutes.

UK £12.50 - EUROPE £13.75 - R. of W. £14.50

FIRETRANS

This utility will transfer a number of FIREBIRD programs from tape to disc automatically including most opening screens in full colour. FIRETRANS will work equally well from tape but will be more convenient to use if converted to disc with SAMSON/Transmat. It will transfer WILLOW PATTERN, RUNESTONE, CHIMERA, GUNSTAR, PARABOLA, REALM, SPIKY HAROLD, BOOTY, DON'T PANIC, GUNFRIGHT, STARGLIDER, NINJA MASTER, HELICOPTER, and some version of THRUST, HARVEY HEADBANGER and BOMBSCARE.

TAPE:- UK £5.00 - EUROPE £6.25 R. of W. £7.00
DISC:- UK £8.50 - EUROPE £9.75 - R. of W. £10.50

NEW

COMPACTOR

NEW

COMPACTOR will allow you to load a standard 17K screen, set the mode, border and ink colours and then save it as a compressed screen containing its own mode and ink colour information. Most screens compact down to an average of 9K which is an enormous saving on disc space. Loading time of compressed screens is also proportionately reduced.

TAPE:- UK £5.00 - EUROPE £6.25 R. of W. £7.00
DISC:- UK £8.50 - EUROPE £9.75 - R. of W. £10.50

TRANSIT

TRANSIT is a disc-to-disc file copier which handles file upto 40K in length in one pass. It will copy from drives A-A, A-B, B-B and B-A making an ideal utility for use with 5 1/4" second drive.

TAPE:- UK £4.50 - EUROPE £5.25 - R. of W. £6.50
DISC:- UK £8.00 - EUROPE £9.25 - R. of W. £10.00

UTILITY DISC No. 1

This utility disc contains 5 programs, all menu driven. They are SAMSON, TRANSIT, QCLONE, VIEWTEXT and the fast disc FORMATTER.

DISC:- UK £15.50 - EUROPE £16.75 - R. of W. £17.50
ROM:- UK £17.25 - EUROPE £18.50 - R. of W. £19.25

ADVANCED MUSIC SYSTEM

When you buy Rainbird's Advanced Music System from us we will give you

ABSOLUTELY FREE OF CHARGE

A disk containing THE GOLDMARK COLLECTION of virtuoso demonstration music files by Rob Baxter some of which have been written especially for us

UK £26.00 - EUROPE £27.25 R. of W. £28.00

Please send your cheque (£ Sterling) Eurocheque OR UK P.O. to
**GOLDMARK SYSTEMS, 51 COMET ROAD, HATFIELD, HERTFORDSHIRE,
AL10 0SY, ENGLAND**

Please write or telephone 07072 71529 for full brochure.

See us at the Show:
October 21-23 1988

AMSTRAD
COMPUTER
SHOW

G-Mex
Manchester

NEW

NIRVANA

NEW

Have you tried backing up your original expensive disc software and failed? Use NIRVANA before its too late! NIRVANA (meaning enlightenment) is an extremely powerful disc handling utility which has the following features: Disc to disc back-up copier which will handle most of the commercially protected discs available today. File copier for individual files. Disc formatter, much easier to use than CPM. Change file attributes. Erase files. Change filenames. Will handle all disc drive combinations

DISC:- UK £14.99 - EUROPE £16.25 - R. of W. £17.00

NEW

SHAREPLAY

NEW

THE STOCK MARKET SIMULATION
(All CPC's)

This is a serious educational program for 1 to 6 players and provides all the enjoyment of playing the stockmarket without any risk of personal bankruptcy! Each player can buy and sell shares and the target is the first to reach £1,000,000. The program includes a stockholding portfolio listing the shares purchased, their number, cost and market value. Bank balances are also shown. Graphical representation of market fluctuations are given in the form of a bar graph. Also included is a high score table. Scores are automatically saved at the end of each session.

DISC:- UK £14.99 - EUROPE £16.25 - R. of W. £17.00

NEW

WORDSEEK

NEW

THE WORDSEARCH PROGRAM
(All CPC's)

This educational program will tax even the most agile mind. The aim is to find the hidden words in a 15 by 15 puzzle within a set time limit of 30 seconds. The time limit is extended for every correct letter of the current word found. You may create your own puzzle consisting of up to 10 words which can be saved to disc and used at any time. You may only retain one puzzle at a time but if you choose not to use your own puzzle then the program will randomly select one from the library of 50 on the disc. All of the puzzles in the library are made up of 10 words each consisting of 1x8 letter, 1x7 letter, 2x6 letter, 3x5 letter, 2x4 letter and 1x3 letter words. This ensures equal difficulty regardless which one is randomly loaded. The program contains a print option (for Epson compatible printers) allowing a hard copy to be made of any puzzle created. Keyboard/Joystick options are also available.

DISC ONLY - U.K. £14.99 - EUROPE £16.25
REST OF THE WORLD £17.00

NEW

TUNESMITH

NEW

TUNESMITH is a simple to use sound utility which allows you to use the keyboard to play and record your tunes. No knowledge of music or Amstrad sound commands is required all you need to be able to do is whistle the tune you play or record. The octave and period of notes is variable and the program includes synthesizer and vibrato effects. TUNESMITH will save any tune as a basic file which can be RUN, CHAINED or MERGED into your own program.

DISC:- UK £14.99 - EUROPE £16.25 R. of W. £17.00

SAMSON

SAMSON has been developed by us to transfer not only the normal programs but also many of today's where the code is much longer. SAMSON differs in many ways from other Tape-to-Disc utilities, the main differences being: * SAMSON retains original file suffixes (SAMSON.SCN will be saved as SAMSON.SCN) * Improved file relocation method * Elaborate Tape-read/Disc-write system which reduces Tape Motor, Slave Replay and Disc Drive Motor wear substantially. * A large reduction in tape transfer time is also achieved in all but a few cases * NEW "SPLIT" option for today's longer games (we will be using this option in future routines) * All file information is displayed on screen and can be echoed to your printer if needed. SAMSON also transfer itself to disc.

TAPE:- UK £7.50 - EUROPE £8.75 - R. of W. £9.50
DISC:- UK £11.50 - EUROPE £12.75 - R. of W. £13.50

CHARACTER DESIGNER

(All CPC's)

* REDEFINE YOUR PRINTER DOWNLOAD CHARACTERS
* REDEFINE THE COMPUTER SCREEN FONT
* REDEFINE ANY/ALL KEYBOARD KEYS (ASWERTY)
* DESIGN SPECIAL SCIENTIFIC CHARACTERS/FONTS

Takes all the hard work out of character designing making it a pleasure. The printer part of the program will only work if your printer is capable of DOWNLOADING and is E.PSON compatible - see your printer manual. Works with 7-bit or 8-bit output (8-bit port). All the designing is done "On-Screen" so you can see exactly what you are doing. You can save your newly designed characters to disc and reload them at any time into a basic program and into most Word-Processors. The program also allows the user to redefine any or all of the keys on the keyboard. This feature will be useful for those who require an ASWERTY keyboard. The disc also contains twelve sample fonts for experimentation

TAPE:- UK £7.99 EUROPE £9.25 - R. of W. £10.00
DISC:- UK £11.99 - EUROPE £13.25 - R. of W. £14.00

THE LOOK

A new series on graphics by Pat McDonald

'When I run the screen dump program by William Weir in AA35', read the letter, 'why do I get Syntax Error in line 90?'

This gentleman was not the only one to have trouble with this listing. And the problems arose not because the program didn't work, but because he didn't understand what it did. He was trying to load in another program to load a screen, rather than relying on the printer dump itself doing the job.

This suggests that there are others who don't fully understand graphics on the Amstrad. And that's hardly surprising. So welcome to a new series that aims to take you right from square one. You don't need any previous computing experience to follow it - but if you aren't a beginner there should be plenty here for you too.

Square one

Your screen consists of an area you can write on and alter, via your keyboard, surrounded by a border that you cannot write on. You can, however, change the border's colour. The area within the border is generally referred to as the **paper area**. On this area the smallest dot (or **pixel**, meaning **picture element**) varies according to how many colours you have. In loud, raucous **mode 0**, for instance, up to 16 colours are available. However, the pixels are very big - the paper area can be thought of as a grid of 160 pixels across by 200 deep.

Compare this with the compromise **mode 1**, the graphics mode the computer is in when you turn it on. It can have four different colours visible at the same time but the grid - or resolution - is finer, comprising 320 across by 200 deep.

When you need high resolution (wordprocessors and spreadsheets spring to mind) **mode 2** is the best. With only two colours to play with you're limited in what you can do, but the horizontal resolution has doubled again to 640 pixels by 200.

It's interesting to compare these different screen modes by typing **MODE 0**, viewing the **Ready** message, then typing **MODE 1** and viewing etc. Notice how the CPC characters consist of the same pixel shapes, but because of the different resolution the characters are distorted in different modes.

In mode 0 the pixels are rectangles lying on their sides, in mode 1 they are roughly square and in mode 2 they're rectangles again, this time standing up.

Note how characters, even if supposedly of different sizes, also follow a grid. This consists of 20 characters across for mode 0, 40 for mode 1 and 80 for mode 2. Not too hard to grasp, is it?

Zoom in

Let's take a closer look at colours. A pixel on an Amstrad screen can be any one of 27 different colours, but the screen mode determines just how many can be used on the screen at once. This range of colours is called the **palette**, and its relationship to the screen is a trickier concept to grasp.

The screen mode has a set number of **ink pens**, into which can go various colours selected from the palette. And then pixels can be set using the inks.

Simple eh? Well, it's round about here things get a little more complicated, because one of the inks is generally referred to as the **paper colour**. This is **ink number 0**, and is used as a background for graphics. Most of the time, that is.

To demonstrate, reset your Amstrad and type the following: **INK 0,9**. This sets the paper colour - ink number 0 - to green. (For a full list of colour numbers refer, e.g., to **Chapter 1, page 48, 6128 manual**.) But it does this for everything already drawn in the background ink - which is most of the screen - instantly. All ink changes are done at a similar speed.

Coming soon: a gallery of your artwork. If you've drawn any graphics on a CPC, send us a tape or disk. Don't forget to enclose an SAE if you want it back, and post it to: *The Look*, Amstrad Action, 4 Queen St, Bath, Avon BA1 1EJ.

A different viewpoint

From the Amstrad's viewpoint, however, everything is different. All it sees is a block of its memory - from 49152 to 65535. If a zero is placed in all of these memory locations, then the whole screen is put to pen/ink 0, i.e. the paper colour.

(Incidentally, the way to use the *Printer Dump* program mentioned above is to save the screen as a binary file when it's actually being displayed. The syntax is:

SAVE "filename",b,49152,16384.

The dump routine now loads back this binary file into the screen, and prints a copy.)

What happens when different numbers are placed in the graphics memory? This is essentially what the **PRINT**, **DRAW** and **PLOT** commands do. More of them next month: for now let's stick with the computer's perspective.



● Mode 0 - pretty but coarse resolution; and mode 1: fewer colours, higher class



Type in **CLS** to clear the screen, and try typing the following: **POKE 49192,n** where **n** is a number from 0 to 255. This changes a particular memory location that corresponds with the top-middle of the screen.

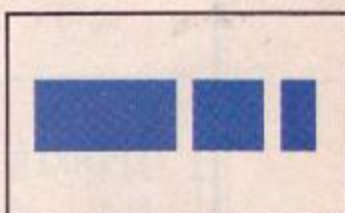

● Mode 0, Mode 1 and Mode 2 pixels

The computer notices the changes to the screen memory, and changes some of the pixels to different ink combinations.

Now type **MODE 2** and repeat the above pokes. Lovers of binary (but what you do in your private life is your own affair) will spot the system automatically.

To compare the number with the pixel formation, do the poke and then type: **PRINT BIN\$(n)**. This gives you a binary (noughts and ones) representation of the number.

Try using **MODE1** and **MODE 0**. It's not so straightforward this time, is it?

Catch next month's *Look* for an explanation.

SOLDERING ON

Stereo for your CPC!

We know how valiantly our Amstrads attempt to entertain us with their efforts at sound. We all wish, secretly, it was a little better. The puny loudspeaker on the machines doesn't help - it's a commonly known fact that small speakers don't reproduce bass sounds at all well.

Just putting the standard mono sound through a bigger speaker isn't the best solution, however. The way to go is to take the stereo output from an Amstrad, amplify it and send it to two different speakers. This results in a much richer sound.

There are commercial equivalents of such a device (the £30 Siren Software *Soundblaster* springs to mind - see AA23) but they cost an awful lot. So here's a project that lets you appreciate CPC sound as opposed to cursing it.

Preparation

The component layout shown is for **Verostrip**, which has pre-cut tracks. You may, of course, use any Veroboard you have on hand. In which case you should be knowledgeable enough to do your own layout from the circuit diagram provided.

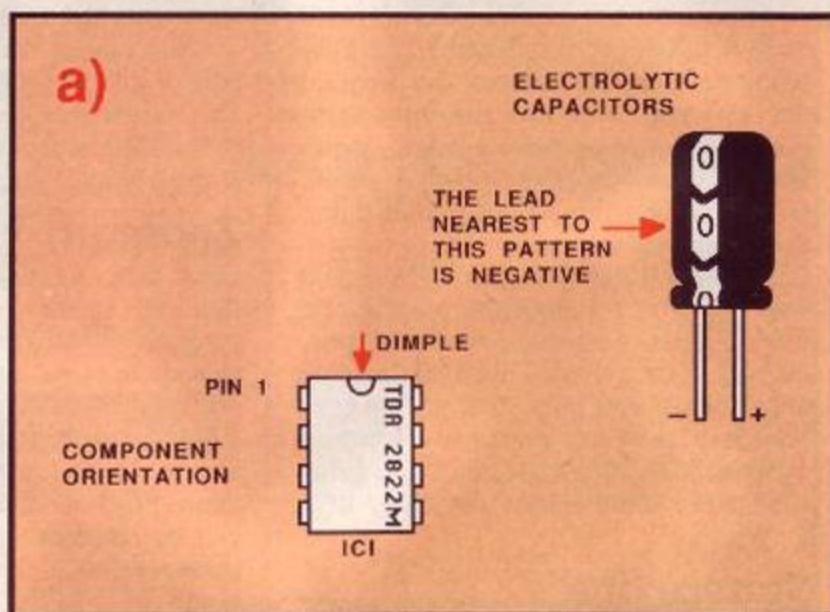
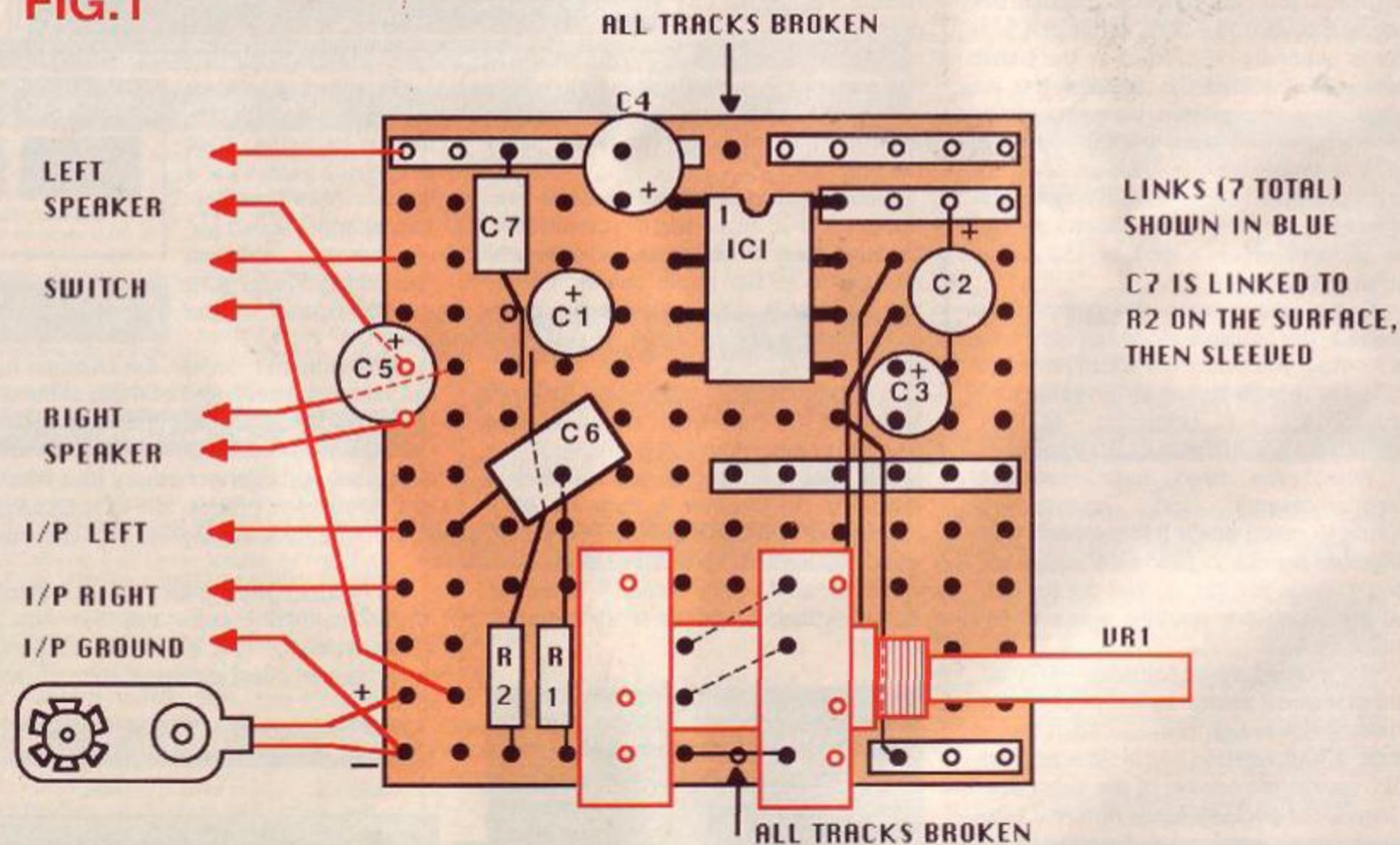

FIG.1



Any more for any more?

Have you a project? We prefer small, easy to build - and cheap! - designs but we consider everything. And we pay too; between £40-£60, according to quality and presentation.

It's a good idea to include full diagrams. Our skilled and dedicated art staff (*snigger snigger*) redraw these, so don't worry if it isn't a work of art - just make it clear and easy to understand. Send your Fairlight emulator to: *Hardware Projects, Amstrad Action, 4 Queen St, Bath BA1 1EJ*

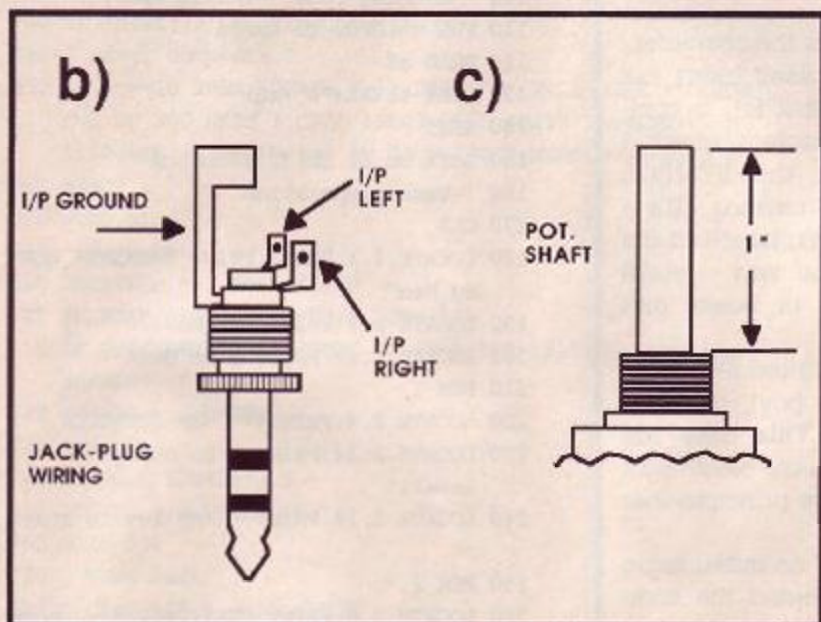

The Verostrip must have all of its tracks cut. The direction of the cut must be across the tracks in the middle of the board. To break tracks, either use a drill bit with some tape on it, or cut using a sharp blade. The first method is preferable as short circuits are less likely.

Construction

First, solder the plain wire links in place (seven in total) as in figure 1. Cut the potentiometer shaft to a little over the right length - too short and the knob won't fit on it. Insert it into the position shown. You may need to enlarge the pot mounting holes slightly. Once you have a fit, solder it. Take your time over the potentiometer: the fit is quite important, because it's a moving part.

Now solder the resistors and capacitors into the board, ensuring that those capacitors marked with a plus (+) are installed the right way round. (Resistors are not so fussy.) Finally, solder the integrated circuit chip into place, again ensuring that it is the correct way round: look for the slot or dimple on the chip.

Next, solder the battery lead, the speaker leads and the input lead into place. Put the stereo jack plug onto the end of the input lead. Before final assembly of the case, you had better test the circuit.

Test it, use it

Solder a link where the on/off switch is to be wired. Plug in the battery, and glorious stereo should come forth. It's amazing the difference this can make on games such as *Glider Rider*, *Uridium* and *ATF*, not to mention the *Advanced Music System* - oh, OK then, and the *Advanced Music System*.

Tidying up

Drill the case as in figure 4. Take some time over this, as it affects the final look of the project. Fit the switch into the case and solder the switch leads (not forgetting to remove the temporary link). You can mount the circuit board and battery using sticky pads. The shaft needs to protrude from the case by about

FIG.2

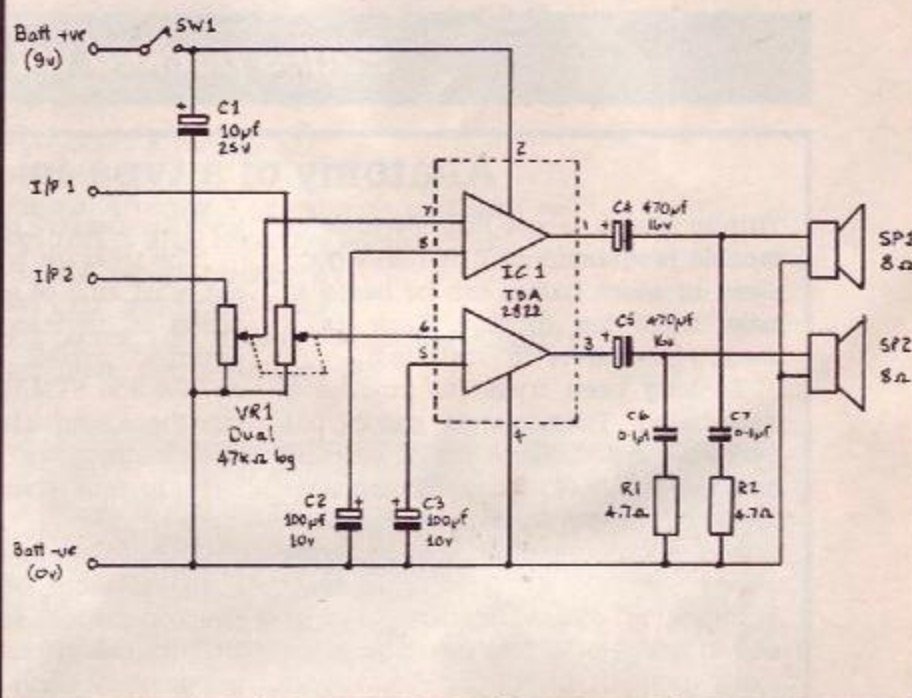

5/16", so trim it until it's right. At this point you need to unsolder the speaker temporarily and input leads, in order to push them through the holes. Assemble the case, fit the knob, and get out those games with the best sound FX.

Component List

Ref	Description	Maplin Code	Unit Cost
R1,2	2 X 4.7 Ohm Resistors	M 4R7	£0.12
VR1	Dual pot., log. 47K Ohms	FX 11 M	£1.60
C1	elect. cap. 10uF 25V	FF 04 E	£0.08
C2,3	2 X elect. cap 100uF 10V	FF 10 L	£0.08
C4,5	2 X elect. cap. 470uF 16V	FF 15 R	£0.25
C6,7	2 X poly cap 0.1uF	WW 41 U	£0.15
IC1	TDA 2822 stereo amplifier	UJ 38 R	£1.50

Hardware

SW1	Switch SPST	YX 64 U	£0.98
	Stereo Jack Plug 3.5mm	HF 98 G	£0.28
	PP3 Battery connector	HF 28 F	£0.12
	Knob	FE 14 Q	£0.28
	Case	LH 14 Q	£0.98
	Verostrip	FL 17 T	£1.80
SP1,2	2 X Loudspeakers	YJ 16 S	£2.50

Abbreviations:

pot. = potentiometer, log. = logarithmic, elect. = electrolytic, cap. = capacitor, poly. = polyester, uF = micro farads, SPST = single pole single travel.

If you already possess some speakers (any 8 Ohm impedance speakers will work) and some Verostrip, then the total cost is just over seven pounds. cost prices are not totally inclusive, so expect to pay more than we list here. Contact: ☎ 0702 554 155, Maplin Electronics Ltd, PO Box 3, Rayleigh, Essex, SS6 8LR.

Take note that the unit

TYPE-INS

Pages packed with powerful programs

Anatomy of a type-in

Writing games is not just a matter of capable programming: it requires good ideas on which games can be based to make them fun to play. Each game needs a good 'story' to illustrate it.

I'd long been trying to produce a maze-based, Pacman-style game, but couldn't solve the problem of collision detection (i.e. how to stop my controlled character walking through maze walls). Then I spotted a short machine-code routine by RpM (*that's Richard Monteiro, of sainted memory, and it was in AA22 -ed.*). This identified characters printed on the screen. I was away!

I incorporated RpM's code, using it to stop the characters falling through barriers and to detect collisions between the character and spikes or gems. Using the INKEY command to detect key presses and joystick movement I gave the player control, positioning the character with the LOCATE command.

As the computer scans the keyboard fifty times every second to see whether a key is being pressed, each key has two states: pressed and not pressed, represented by 0 and -1 respectively. Each key also has a number identifying it.

So INKEY (47)=0 THEN... to the computer means, "If key number 47 (space bar) is being pressed then..."

The character's position is determined by two variables, x and y. In response to the player's control the character can be deleted, its co-ordinates (x and y) changed, and the character reprinted in a new location. For instance, LOCATE x,y:?" * deletes the character; x=x+1 changes its position (in this case, moves it right); LOCATE

x,y:?" <character> reprints the character.

The treasure hunter itself (don't ask me what kind of a beast it is!) is composed of graphics characters which I designed myself using the SYMBOL AFTER and SYMBOL commands. (It's a pity these aren't clearly explained in the User Instructions, by the way - you'll have to look them up in books and mags.)

The characters are printed alternately in the same location (x,y), giving a near animation effect. This uses the NOT command (based on the electronics not-gate), working on the principle that NOT 1=0 and NOT 0=-1.

I gave the variable 'a' an initial value of 0 (line 310), and included the command a=NOT a (line 660) in the program. The value of 'a' alternates between 0 and -1, and the character printed depends on these values (lines 510 and 520).

I added some sound commands to produce short notes as the character falls or rises, the tone depending on the position of the character (variable y).

Then I added colour using then INK, PEN and BORDER commands, all of which are well explained in the User Instructions. I had to exercise great care over my choice of colours since I was working with a green screen monitor.

Hope you enjoy playing *Treasure Hunt* as much as I did writing it!

Benedict Garrett, 16, is a sixth former at Launceston College, Cornwall, studying A level maths, physics and chemistry. He hopes to study computer science at university.

Oops!

It was the heat... there was a power-cut... the office was off sick... the editor had a brain-storm... Pleeease! You've got to believe us.

That's right, we're talking about last month's spectacular boo-boo. Brilliant as it was, we had no intention of printing W.R.Street's 'Personal Spending' program twice (and no, W.R.Street, you don't get paid twice!). That also meant that Ben Garrett's 'Treasure Hunt' got cut off in its prime. So to make amends we're printing it again - but this time in full (we hope!).

Treasure Hunt

```
1 'Treasure Hunt
2 'By Benedict Garrett
3 'Amstrad Action September 1988
10 ' Variables, inks, graphics.
20 MODE 0:sc=0:lev=1:scr=0
30 INK 0,11:BORDER 11
40 INK 1,24:INK 2,6:INK 3,0:INK 4,15,3
50 RANDOMIZE TIME:SYMBOL AFTER 250
60 SYMBOL 250,255,171,213,171,213,171,
213,255
70 SYMBOL 251,8,8,8,28,28,62,62,127
80 SYMBOL 252,60,126,219,255,129,195,
126,195
```

```
90 SYMBOL 253,0,0,60,126,219,255,126,195
100 ' Machine code ( Thanks RpM ).
110 FOR t=&BF00 TO &BF06
120 READ a$
130 POKE t,VAL("&"a$)
140 NEXT
150 DATA cd,60,bb,32,07,bf,c9
160 ' Game preparation
170 CLS
180 LOCATE 1,1:PEN 3:PRINT"TREASURE HUNT
By Ben"
190 LOCATE 1,2:PRINT STRING$(20,"=")
200 LOCATE 5,12:PRINT"Q to Quit"
210 PEN 1
220 LOCATE 2,4:PRINT"** USE JOYSTICK **"
230 LOCATE 2,14:PRINT"L to change
level."
240 LOCATE 1,24:PRINT"< Any key to start
>"
250 PEN 2
260 LOCATE 3,6:PRINT CHR$(240);"...move
up."
270 LOCATE 3,8:PRINT CHR$(242);"...move
left."
280 LOCATE 3,10:PRINT CHR$(243);
"...move right."
290 PEN 1:LOCATE 6,20:PRINT"Level : "lev
300 PEN 3:LOCATE 7,22:PRINT"Score"scr
310 x=2:y=2:a=0
320 CALL &BB03:CALL &BB18
330 IF INKEY(67)=0 THEN PEN 1:MODE
2:LIST
340 IF INKEY(36)=0 AND lev=1 THEN PEN
3:LOCATE 5,17:INPUT "Level:",lev:
GOTO 350 ELSE 360
350 IF lev<1 OR lev>30 THEN lev=1:GOTO
170
360 CLS:PEN 1:FOR f=1 TO 20
370 LOCATE f,1:PRINT CHR$(250)
380 LOCATE f,24:PRINT CHR$(250)
390 NEXT
400 FOR f=1 TO 24
410 LOCATE 1,f:PRINT CHR$(250)
420 LOCATE 20,f:PRINT CHR$(250)
430 NEXT
440 FOR f=1 TO 90+(5*lev)
450 LOCATEINT(RND(1)*18+2),
INT(RND(1)*22+3):PEN 1:PRINT
CHR$(250):NEXT
460 FOR f=1 TO 5+5*lev:LOCATE
INT(RND(1)*17+3),INT(RND(1)
*21+2):PEN 3:PRINT CHR$(251):NEXT
470 PEN 4:FOR f=1 TO 10
480 LOCATE INT(RND(1)*17+3)
,INT(RND(1)*21+2):CALL &BF00:
IF PEEK(&BF07)=227 THEN 480 ELSE
PRINT CHR$(227)
490 NEXT
500 ' Game start
510 IF a=0 THEN a$=CHR$(252)
520 IF a=-1 THEN a$=CHR$(253)
```

```

530 PEN 2:LOCATE x,y:PRINT a$
540 LOCATE x,y+1:CALL &BF00
550 IF PEEK(&BF07)=227 THEN SOUND 1,300,10,7:sc=sc+1:scr
    =scr+lev
560 IF PEEK(&BF07)<>250 AND INKEY(72)<>0 THEN LOCATE x,y:
    PRINT " :y=y+1:LOCATE x,y:SOUND 2,500+25*y,5,7:PRINT a$
570 LOCATE x,y+1:CALL &BF00
580 ' Player dead ?
590 IF PEEK(&BF07)=251 THEN 930
600 IF INKEY(72)=0 OR INKEY(76)=0 THEN GOTO 690
610 IF INKEY(67)=0 THEN 930
620 IF INKEY(74)=0 THEN GOTO 780
630 IF INKEY(75)=0 THEN GOTO 860
640 ' Level complete ?
650 IF sc>=10 THEN LOCATE 3,12:PRINT"** WELL DONE **":FOR
    f=1 TO 300:NEXT f:CALL &BB03:CALL &BB18:lev=lev
    1:LOCATE 1,24:FOR f=1 TO 30:PRINT"":NEXT:sc=0:GOTO 290
660 a=NOT a
670 GOTO 510
680 ' Move up
690 LOCATE x,y-1:CALL &BF00
700 IF PEEK(&BF07)=250 THEN GOTO 530
710 IF PEEK(&BF07)=227 THEN SOUND 1,300,10,7:sc=sc+1:scr=
    scr+lev
720 LOCATE x,y:PRINT " "
730 y=y-1
740 SOUND 2,500+25*y,5,7
750 LOCATE x,y:PRINT a$
760 GOTO 530
770 ' Move left
780 LOCATE x-1,y:CALL &BF00
790 IF PEEK(&BF07)=250 THEN GOTO 530
800 IF PEEK(&BF07)=227 THEN SOUND 1,300,10,7:sc=sc+1:scr
    =scr+lev
810 LOCATE x,y:PRINT " "

```

```

820 x=x-1
830 LOCATE x,y:PRINT a$
840 GOTO 530
850 ' Move right
860 LOCATE x+1,y:CALL &BF00
870 IF PEEK(&BF07)=250 THEN GOTO 530
880 IF PEEK(&BF07)=227 THEN SOUND 1,300,10,7:sc=sc+1:scr
    =scr+lev
890 LOCATE x,y:PRINT " "
900 x=x+1
910 LOCATE x,y:PRINT a$
920 GOTO 530
930 PEN 3:LOCATE 3,12:PRINT"** GAME OVER **"
940 LOCATE 3,14:PRINT"You scored.."scr
950 FOR f=1 TO 300:NEXT f
960 CALL &BB03:CALL &BB18
970 LOCATE 1,24:FOR f=1 TO 30:PRINT"":NEXT
980 lev=1:sc=0:scr=0:GOTO 170

```

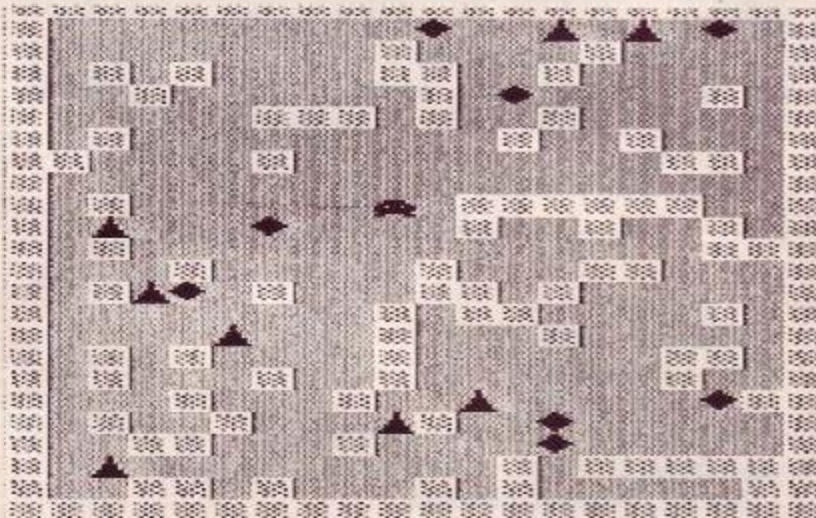

Magic

'Magic' sets up an RSX command that can be used to replace any particular data byte in screen memory with a different byte. This can be used to create some novel effects on graphic screens.

It has been written (like the real time clock) by Simon Payne who lives in Blackpool.

```

1 'Magic
2 'By Simon Payne
3 'Amstrad Action October 1988
10 LN=100
20 FOR ADR=&A000 TO &A030 STEP 13
30 READ BYTE$:CHK=0
40 FOR I=0 TO 12
50 V=VAL("&"+MID$(BYTE$,I*2+1,2))
60 POKE ADR+I,V:CHK=CHK+V
70 NEXT
80 IF CHK<>VAL("&"+RIGHT$(BYTE$,3)) THEN PRINT "ERROR
    IN LINE :";LN:STOP
90 LN=LN+10:NEXT
100 DATA 2109A0010DA0CDD1BC000000003D2

```

```

110 DATA 12A0C318A04D414749C300210042F
120 DATA C0DD5600DD5E027BBECC2CA023624
130 DATA 7DB4C818F57A77C9000000000004C0
140 CALL &A000,0,0
150 MODE 1
160 PRINT "Magic Paint now active"
170 PRINT:PRINT
180 PRINT " eg. |MAGIC,0,103":PRINT
190 PRINT "This will search the screen for the byte0
    and change it to 103"
200 PRINT "GO ON TRY IT"
210 PRINT
220 PRINT "|MAGIC,OLD BYTE,NEW BYTE"

```

Program Notes

This program is a little out of the ordinary, because it was written after the author had seen an Archimedes Art program which had a similar feature.

Lines 10-90 read in the data stored in lines 100-130, and poke this data into memory. Line 140 then runs through this code, which makes ready the new command.

Here, have some money!

Send us your listings and not only do you stand a very good chance of getting in print in your favourite magazine, you could also earn yourself £100. Every *Type-In* we publish is paid for, and £10 is the absolute minimum. So what are you waiting for? Send your tape or disk - and a printout if you can - to *Type-Ins*, *Amstrad Action*, Future Publishing Ltd, 4 Queen St, Bath, BA1 1EJ. And here's a few tips you may find useful:

- Send only your own original unpublished work;

- Use lower-case, not capitals, for variable names;
 - REM statements make the program easier to understand;
 - Don't use letters that look like numbers as variable names (O and 0, for instance, or l and 1);
 - Avoid lengthy multi-statements. Short lines aid debugging;
 - And ensure your name and address are on every piece of paper, cassette and disk you send.
 - If you'd like to reach an even larger audience, declare that you are putting your contribution into the Public Domain.
- Oh, and one final thing. Good luck!

Multi Prog

For all those 464 owners who are annoyed at continually being ignored by *Type-Ins* contributors – this is for you. It's a fairly complex program that allows the storing of up to nine short Basic programs at once. The program sets up 5 RSX's:

|INIT, n, add – Each program is referred to by number. When first run *Multi Prog* is looking at &170, the regular start of Basic slot, and all of the other slots are uninitialized. This routine initializes program space at address **add** for program number **n**. Make sure programs don't overlap, and also ensure that at least 2K is left below **Himem** to use the disk.

|SELECT, n – This makes Basic look at program **n**. There'll be nothing there at first, so **LOAD** something in the usual manner.

|PROGS – Displays information about each of the 9 programs, including start and end addresses and if each of them have been initialized.

|CLEAR – The same as **NEW** for the currently selected program. Do not use **NEW** itself! This is very important.

|DELETE, n – Clears program **n** and returns it to an uninitialized state. So then you can redefine it. NB you can't **|DELETE** the currently selected program, only a different one.

It might be stating the obvious, but don't use any of these commands from within a Basic program.

```

1 'Multi Prog
2 'By J Longley
3 'Amstrad Action October 1988
10 MEMORY &8FFF:ADD=&9000
20 FOR f=100 TO 750 STEP 10
30 CHK=0:FOR g=1 TO 16
40 READ a$:a=VAL("&"a$)
50 POKE add,a:ADD=ADD+1:CHK=CHK+a
60 NEXT
70 READ b$:IF CHK<>VAL("&"b$) THEN PRINT "Error in line "
;f:END
80 NEXT
90 CALL &9000:PRINT "Multi-Prog now active"
100 DATA 21,81,AE,11,3F,91,01,0A,00,ED,B0,01,18,90,21,14,4B7
110 DATA 90,C3,D1,BC,ED,A3,18,90,29,90,C3,44,90,C3,2D,93,8BB
120 DATA C3,9D,91,C3,7D,93,C3,3F,92,49,4E,49,D4,43,4C,45,7E0
130 DATA 41,D2,53,45,4C,45,43,D4,44,45,4C,45,54,C5,50,52,628
140 DATA 4F,47,D3,00,FE,02,21,D3,90,C2,2C,91,DD,7E,02,21,6EA
150 DATA 1F,91,FE,00,CA,2C,91,FE,0A,D2,2C,91,4F,06,00,21,642
160 DATA 35,91,09,7E,FE,01,36,01,21,E3,90,CA,2C,91,3A,9A,672
170 DATA 91,47,AF,C6,0A,10,FC,4F,06,00,21,35,91,09,EB,21,5B4
180 DATA 81,AE,01,0A,00,ED,B0,DD,7E,02,32,9A,91,DD,6E,00,6DC
190 DATA DD,66,01,2B,22,81,AE,23,23,23,22,83,AE,22,85,AE,5D1
200 DATA 22,87,AE,22,89,AE,DD,7E,02,47,AF,C6,0A,10,FC,4F,72E
210 DATA 06,00,21,35,91,09,EB,21,81,AE,01,0A,00,ED,B0,21,4FA
220 DATA FF,90,CD,2C,91,DD,7E,02,C6,30,CD,5A,BB,21,0F,91,80F
230 DATA C3,2C,91,50,61,72,61,6D,65,74,65,72,20,45,72,72,66A
240 DATA 6F,72,00,50,72,6F,67,72,61,6D,20,61,6C,72,65,61,5DE
250 DATA 64,79,20,69,6E,69,74,69,61,6C,69,7A,65,64,00,50,5E3
260 DATA 72,6F,67,72,61,6D,20,6E,75,6D,62,65,72,20,00,20,571
270 DATA 69,6E,69,74,69,61,6C,69,7A,65,64,20,4F,4B,00,4F,59F
280 DATA 75,74,20,6F,66,20,72,61,6E,67,65,00,7E,CD,5A,BB,66B
290 DATA B7,C8,23,C3,2C,91,01,00,00,00,00,00,00,00,00,323
300 DATA 00,00,00,00,00,00,00,00,00,00,00,00,00,00,00,0
310 DATA 00,00,00,00,00,00,00,00,00,00,00,00,00,00,00,0
320 DATA 00,00,00,00,00,00,00,00,00,00,00,00,00,00,00,0
330 DATA 00,00,00,00,00,00,00,00,00,00,00,00,00,00,00,0
340 DATA 00,00,00,00,00,00,00,00,00,00,00,00,00,00,00,0
350 DATA 00,00,00,00,00,00,00,00,00,00,01,01,01,00,FE,01,21,123
360 DATA D3,90,C2,2C,91,DD,7E,00,21,1F,91,FE,00,CA,2C,91,793
370 DATA FE,0A,D2,2C,91,4F,06,00,21,35,91,09,7E,21,27,92,534
380 DATA FE,01,C2,2C,91,3A,9A,91,47,AF,C6,0A,10,FC,21,35,70B
390 DATA 91,4F,06,00,09,11,81,AE,EB,01,0A,00,ED,B0,DD,7E,61D
400 DATA 00,47,AF,C6,0A,10,FC,21,35,91,4F,06,00,09,11,81,4A9
410 DATA AE,01,0A,00,ED,B0,DD,7E,00,32,9A,91,21,10,92,CD,69E

```

```

420 DATA 2C,91,DD,7E,00,C6,30,CD,5A,BB,21,19,92,C3,2C,91,73C
430 DATA 50,72,6F,67,72,61,6D,20,00,20,6E,6F,77,20,73,65,564
440 DATA 6C,65,63,74,65,64,00,50,72,6F,67,72,61,6D,20,6E,5D7
450 DATA 6F,74,20,69,6E,69,74,69,61,6C,69,7A,65,64,00,3A,5D3
460 DATA 9A,91,DD,21,9B,91,DD,77,00,3E,15,CD,5A,BB,3E,01,71D
470 DATA CD,90,91,3E,06,CD,5A,BB,3E,01,F5,21,EF,92,CD,2C,7F0
480 DATA 91,F1,F5,C6,30,CD,5A,BB,21,FA,92,CD,2C,91,F1,F5,A6C
490 DATA 4F,06,00,21,35,91,09,7E,FE,01,20,3B,21,FE,92,CD,59B
500 DATA 2C,91,F1,F5,47,AF,C6,0A,10,FC,21,35,91,4F,06,00,6B1
510 DATA 09,EB,1A,6F,13,1A,67,23,CD,CC,92,21,08,93,CD,2C,614
520 DATA 91,13,13,13,13,13,13,13,1A,6F,13,1A,67,CD,CC,92,45E
530 DATA F1,3C,FE,0A,20,A4,C9,21,13,93,CD,2C,91,F1,F5,C6,8BF
540 DATA 30,CD,5A,BB,21,1C,93,CD,2C,91,18,E4,7C,CD,D5,92,818
550 DATA 7D,CD,D5,92,C9,F5,0F,0F,0F,0F,CD,DE,92,F1,CD,E5,98B
560 DATA 92,CD,5A,BB,C9,E6,0F,C6,30,FE,3A,D8,C6,07,C9,0D,8DB
570 DATA 0A,50,72,6F,67,72,61,6D,20,00,20,3A,20,00,53,74,443
580 DATA 61,72,74,20,3A,20,26,00,20,20,20,45,6E,64,20,3A,3B8
590 DATA 20,26,00,50,72,6F,67,72,61,6D,20,00,20,6E,6F,74,4AF
600 DATA 20,69,6E,69,74,69,61,6C,69,7A,65,64,00,2A,89,AE,617
610 DATA EB,2A,81,AE,E5,23,36,00,23,7C,BA,20,F9,7D,BB,20,74C
620 DATA F5,E1,22,81,AE,23,23,23,22,83,AE,22,85,AE,22,87,6E1
630 DATA AE,22,89,AE,21,68,93,CD,2C,91,3A,9A,91,C6,30,CD,7D5
640 DATA 5A,BB,21,71,93,C3,2C,91,50,72,6F,67,72,61,6D,20,6B2
650 DATA 00,20,63,6C,65,61,72,65,64,20,4F,4B,00,FE,01,21,4CA
660 DATA D3,90,C2,2C,91,DD,7E,00,21,9A,91,BE,21,FD,93,CA,8C2
670 DATA 2C,91,F5,21,1F,91,FE,00,CA,2C,91,FE,0A,D2,2C,91,79F
680 DATA 4F,06,00,21,35,91,09,7E,21,27,92,FE,01,C2,2C,91,51B
690 DATA 3E,15,CD,5A,BB,3A,9A,91,F5,DD,77,00,CD,C5,91,CD,8D3
700 DATA 2D,93,F1,CD,C5,91,F1,F5,4F,06,00,21,35,91,09,36,735
710 DATA 00,3E,06,CD,5A,BB,21,E8,93,CD,2C,91,F1,C6,30,CD,800
720 DATA 5A,BB,21,F1,93,C3,2C,91,50,72,6F,67,72,61,6D,20,732
730 DATA 00,20,64,65,6C,65,74,65,64,20,4F,4B,00,43,61,6E,4C3
740 DATA 6E,6F,74,20,64,65,6C,65,74,65,20,63,75,72,72,65,625
750 DATA 6E,74,20,70,72,6F,67,72,61,6D,00,00,00,00,00,00,3FA

```

Program Notes

It's a fairly conventional machine code loader. At line 10 memory is reserved. Lines 20-60 read the data in and

poke it into memory. Lines 70 and 80 check that you have entered the data correctly, and line 90 runs the machine code, installing *Multi Prog*.

Real Time Clock

We've had no shortage of programs that turn the CPC into a clock. This one from **Simon Payne** – resident in Blackpool – is a bit special though, because it creates a clock that doesn't get in the way, letting your computer get on with life. When you want to see what the time is, just press the **ENTER** key. (That's the small **ENTER** key on 464's.)

```

10 REM Real Time Clock (RTC)
20 REM By Simon Payne
30 REM Amstrad Action October 1988
40 REM SECONDS ARE STORED AT &9C40
50 REM MINUTES ARE STORED AT &9C41
60 REM HOURS ARE STORED AT &9C42
70 MODE 1
80 LN=180
90 FOR ADR=&8000 TO &809F STEP 13
100 READ BYTE$:CHK=0
110 FOR I=0 TO 12
120 V=VAL("&"MID$(BYTE$,I*2+1,2))
130 POKE ADR+I,V:CHK=CHK+V
140 NEXT
150 LOCATE 10,10:PRINT "CHECKING LINE ";LN
160 IF CHK<>VAL("&"RIGHT$(BYTE$,3)) THEN PRINT
"ERROR IN LINE ";LN:STOP
170 LN=LN+10:NEXT
180 DATA 21A2800681111D80C3EFBC219C5A3
190 DATA 80113200013200C3E9BC219C8049B

```

```
200 DATA C3ECBC3A409C3CFE3CCC2D80326A2
210 DATA 409CCD5680C93A419C3CFE3CCC6A1
220 DATA 3F8032419C3E0032409CC93A4245F
230 DATA 9C3CFE18CC000032429C3E003243A
```

```
240 DATA 419C3E07CD5ABBC93E06CD1EBB5B7
250 DATA C83A429CCD83803E3ACD5ABB3A644
260 DATA 419CCD83803E3ACD5ABB3A409C61D
270 DATA CD83803E07CD5ABB3E0DCD5ABB624
280 DATA C9160ACD8A8016010E009238033B2
290 DATA 0C18FA82F579C630CD5ABBF1C97A0
300 DATA 00000000000000000000000000000000
310 CALL &8000:CALL &800B
320 MODE 1:INPUT "ENTER HOUR ";H:POKE 40002,H
330 INPUT "ENTER MIN ";H:POKE 40001,H
340 INPUT "ENTER SEC ";H:POKE 40000,H
350 MODE 1:PRINT "TIME SET. PRESS THE SMALL ENTER KEY TO
SEE THE TIME"
```

Program Notes

Lines 70-170 perform the data reading and error checking on the data. This data is stored in lines 180-300, and it's the clock program itself written in machine code. Line

310 runs this machine code, setting up the clock, and lines 320-340 are used to input the start time. Finally, line 350 prints up the minimal instructions on usage.

Trapper

Yes, it's another version of the classic bike game of Tron. Two players each guide a different coloured track around the screen. They have to try and crash the other player into a bike trail.

J Fox-Geen wrote this program. Player one uses z and x to turn left and right, player two uses < and >.

```
10 REM Trapper
20 REM By J.Fox-Geen
30 REM Amstrad Action 1988
40 MODE 1:BORDER 0:INK 0,0:INK 1,24:INK 2,6
50 DRAW 0,365,1:DRAW 635,365:DRAW 635,0:DRAW 0,0
60 d1%=2:d2%=4:x1%=20:y1%=20:x2%=620:y2%=20
70 LOCATE 17,1:PRINT "Trapper by J.Fox-Geen"
80 LOCATE 17,2:PRINT "-----"
90 PLOT x1%,y1%,1:PLOT x2%,y2%,2:i$=INKEY$
```

Program Notes

Lines 40-80 get the screen up and running, lines 90-270 run the game, and the final few bits announce the winner. A fair example of a

tightly written game - but notice the huge amounts of statements to work out the new coordinates from 100-250.

```
100 IF i$="z" THEN d1%=d1%-1
110 IF i$="x" THEN d1%=d1%+1
120 IF i$="," THEN d2%=d2%-1
130 IF i$="." THEN d2%=d2%+1
140 IF d1%=0 THEN d1%=4
150 IF d1%=5 THEN d1%=1
160 IF d2%=0 THEN d2%=4
170 IF d2%=5 THEN d2%=1
180 IF d1%=1 THEN y1%=y1%+2
190 IF d1%=2 THEN x1%=x1%+2
200 IF d1%=3 THEN y1%=y1%-2
210 IF d1%=4 THEN x1%=x1%-2
220 IF d2%=1 THEN y2%=y2%+2
230 IF d2%=2 THEN x2%=x2%+2
240 IF d2%=3 THEN y2%=y2%-2
250 IF d2%=4 THEN x2%=x2%-2
260 IF TEST(x1%,y1%)<>0 THEN GOTO 280
265 IF TEST(x2%,y2%)<>0 THEN GOTO 285
270 GOTO 90
280 a$="Player 1 CRASHED !!!":GOTO 290
285 a$="Player 2 CRASHED !!!"
290 LOCATE 11,7:PRINT a$:LOCATE 7,24:PRINT "Press any
key to play again":FOR n=0 TO 100:NEXT:CALL
&8B18:RUN
```

New Character Sets

Paul Waterman, whose abode is in Southampton, has sat down and reworked an old *Type-In* into a whole new form, ie using machine code. This has improved it no end at all.

So if you want to use italic, under lined and double height on your Amstrad, start typing! Characters 128-255 are reserved, so you can't use them in your own programs.

```
5 ' New Character Sets
6 ' By Paul Waterman
7 ' Amstrad Action October 1988
10 MODE 2:MEMORY &8FFF
20 dn=120
30 add=&9000
40 READ a$:IF LEN(a$)=4 THEN GOSUB 100
50 IF a$="endofdata" THEN 80
60 POKE add,VAL("&"+a$):add=add+1:total=total+VAL("&"+a$)
70 GOTO 40
80 CALL &9000
90 PRINT CHR$(128):GOTO 320
100 IF VAL("&"+a$)<>total THEN PRINT "Error in line ";dn:
GOTO 2
110 dn=dn+10:total=0:READ a$:PRINT "Checking line ";dn:
RETURN
120 DATA 11,00,01,CD,AB,BB,11,20,00,21,6F,91,CD,AB,BB,DD,7E,
00,FE,00,0823
```

```
130 DATA CA,23,90,3E,C3,32,5A,BB,21,44,90,22,5B,BB,C9,3E,CF,
32,5A,BB,090F
140 DATA 21,00,94,22,5B,BB,C9,3E,20,CD,A5,BB,01,08,03,7E,CB,
3F,A6,77,07F2
150 DATA 23,0B,78,B1,C2,37,90,C9,FE,7F,F2,4C,90,CF,00,94,C5,
D5,E5,CD,0BA3
160 DATA 63,91,CB,3F,F5,DC,85,90,F1,CB,3F,F5,DC,8E,90,F1,CB,
3F,F5,DC,0D9A
170 DATA E4,90,F1,CB,3F,F5,DC,C2,90,F1,CB,3F,F5,DC,A9,90,F1,
CB,3F,F5,0E87
180 DATA DC,97,90,F1,CB,3F,DC,F6,90,E1,D1,C1,C9,3E,B6,32,3A,
90,CD,2F,0C88
190 DATA 90,C9,3E,A6,32,3A,90,CD,2F,90,C9,3E,21,F5,CD,A5,BB,
2B,3E,FF,0A77
200 DATA 77,F1,3C,FE,80,C2,99,90,C9,3E,20,F5,CD,A5,BB,06,04,
C5,7E,CB,0B6E
210 DATA 3F,77,C1,23,10,F7,F1,3C,FE,80,C2,AB,90,C9,3E,20,CD,
A5,BB,06,0AA3
220 DATA 61,C5,06,03,7E,CB,3F,B6,77,23,10,F8,23,23,06,03,7E,
CB,3F,A6,078C
230 DATA 77,23,10,F8,C1,10,E6,C9,3E,20,CD,A5,BB,01,08,03,CB,
A6,23,0B,0858
240 DATA 78,B1,C2,EC,90,C9,F5,E5,3E,C3,21,06,91,32,5A,BB,22,
5B,BB,E1,0B23
250 DATA F1,C9,FE,80,F2,4C,90,FE,20,FA,54,91,F5,C5,D5,E5,F5,
3E,FE,CD,0E75
260 DATA A5,BB,EB,F1,D5,CD,A5,BB,D1,06,08,7E,12,13,12,23,13,
10,F8,21,0931
270 DATA 3B,91,7E,FE,00,CA,41,91,CD,51,91,23,C3,2E,91,FE,0A,
```

```

08,FF,0B,0952
280 DATA 00,CD,78,BB,7C,FE,01,3E,0A,CC,51,91,E1,D1,C1,F1,C9,
    CF,00,94,0B01
290 DATA FE,0D,C2,51,91,3E,0D,CD,51,91,3E,0A,C3,51,91,F5,C5,
    D5,E5,CD,0AD7
300 DATA 00,90,E1,D1,C1,F1,C9,00,00,00,00,00,00,00,00,00,00,
    00,00,00,04BD
310 DATA endofdata
320 ' saving instructions: SAVE "PRINT.BIN",b,&9000,&170
330 ' USER GUIDE ps You don't need the next bit
340 MODE 1:PRINT " Brief User Guide":PRINT:PRINT:
    PRINT
350 PRINT "To use the new character sets you must first";
    CHR$(129) " 'CALL &9000,1':CHR$(128):" to turn them on."
360 PRINT:PRINT " Then you must use the old ";CHR$(130):
    "PRINT CHR$(n)":CHR$(128);
370 PRINT " command to call each new character set."
380 PRINT:PRINT "Where 'n' is a number between 128 and
    255. To know what 'n' should be you have to decide
    which bits in the number to set."
390 LOCATE 1,25:PRINT " Press Any key to continue"
400 CALL &BB18
410 MODE 1:PRINT " Which Bits":PRINT:PRINT:PRINT
420 PRINT "Set the following bits in the number to get the
    required results.":PRINT
430 PRINT "Bit 7- Must always be set"
440 PRINT CHR$(192):"Bit 6- Double height"
450 PRINT CHR$(160):"Bit 5- Underlined"
460 PRINT CHR$(144):"Bit 4- Italic"
470 PRINT CHR$(136):"Bit 3- Horror"

```

Program Notes

Line 10 sets the screen mode and the memory limit. Lines 20-40 read in data that makes up the machine code. Line 50 catches the last item and makes the program continue.

Lines 60-70 complete the reading operation, looping if necessary.

Line 80 calls the machine

code, which then sets up the fonts. Line 90 jumps to line 320 onwards, saving out the machine code to tape or disk and then printing the instructions.

Lines 100 and 110 perform checks on the data to make sure of the quality of your typing!

Lines 120-310 contain the machine code data itself.

```

480 PRINT CHR$(132):"Bit 2- Army"
490 PRINT CHR$(130):"Bit 1- Thin"
500 PRINT CHR$(129):"Bit 0- Thick"
510 LOCATE 1,25:PRINT CHR$(128) " Press Any key to
    continue":CALL &BB18
520 MODE 1:PRINT " Mixers"
530 PRINT:PRINT:PRINT "Of course you can set more than 1
    bit inthe number and mix 2 or more stlyes."
540 PRINT:PRINT "e.g setting bits 7,6,5 and 0 gives you:"
550 PRINT "&X11100001 = 225 (PRINT CHR$(225))"
560 PRINT:PRINT:PRINT CHR$(225)"Thick Underlined Double
    height letters"
570 PRINT:PRINT:PRINT CHR$(128)"To return to normal
    characters type 'PRINT CHR$(128)' and to turn off
    completely type 'CALL &9000,0'"

```

PRODUCE PICTURES LIKE THESE IN "MINUTES"
USING A DMP 2000 / 2160 / 3000 / 3160 PRINTER AND THE

DART SCANNER

A remarkable new image scanning system which enables you to recreate & store pictures, documents, drawings, photographs etc.

- No camera or video source needed
Simply feed your original into DMP 2000 / 2160 / 3000 / 3160 printer (does not affect normal printing operations)
- Compatible with AMX Pagemaker and any light pen or mouse which works with standard screen format
- For all CPC computers

Features:
Scan - Magnification x1, x2, x3, x6
Print - Full Size/Half Size, Load & Save to Tape or Disc, Area Copy, Scrolling Window, Zoom Edit, Box/Blank, Clear Area, Add Text, Flip Screen, On screen Menu.

Applications:
Advertising/Artwork, Letterheads/Logo's, Newsletters & Leaflets, Games Screens.



Package Comprises:
Scanner head, Interface,
Software on Cassette or Disc

R.R.P. £79.95
including VAT and P&P

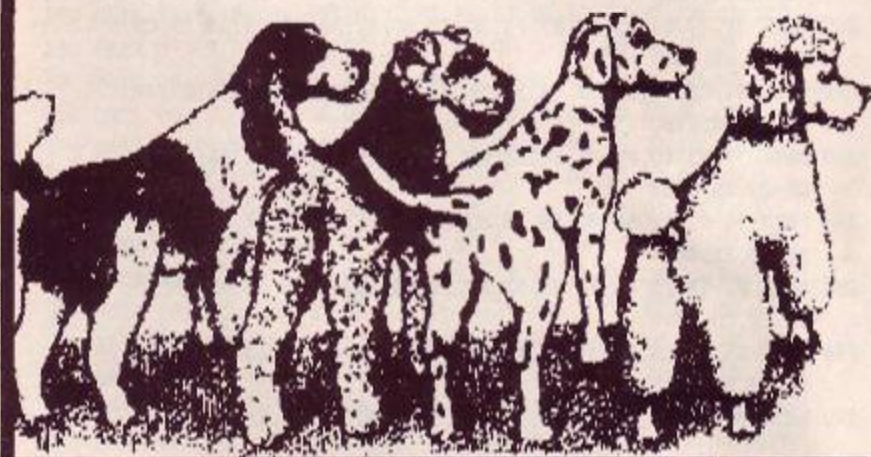

DART Electronics



Telephone: (0502) 513707

Trade & Export enquiries also welcome

Unit B5
Oulton Works
School Road
LOWESTOFT
Suffolk NR33 9NA

AA SMALL ADS

FOR SALE

CPC 664, modulator for use with TV £180 + Multiface 2 £30 + DMP1 Printer £60 + 2 romboards, Protext, Prospell, Promerge, Rodos, £20 each. 2nd disc drive £65. Tel: Portsmouth 690349.

Amstrad CPC464 colour monitor, joystick, manual plus books, lots of software, 120+ utilities, AA magazines 1-27. Includes GAC, EMU (music) etc. £250 or PX for Atari 520ST. Tel: (0924) 831144 Mon-Fri after 6pm. (Joe) Wigan.

Amstrad CPC464 with colour monitor, 64K silicon disc, disc drive, speech synth, mags, books +. £550 or above. Highest offer gets Rombo Video Digitizer FREE!! Tel: 01 993 3174 after 8pm & ask for Roy.

Basic programmers! For £4.99 you can have machine code sprites in your programs, using user-friendly software. Simply send 25p + SAE for details. M Gledhill, 21 Newtake Road, Tavistock, Devon. PL19 9BX.

CPC 6128, colour monitor, DMP 2000, joystick, cassette player, magazines, loads of software, including Protext, Advanced Art Studio, Renegade, ATF. Cost over £1100, take £800 ono. Phone Henley (0491) 579618.

Rombo romboard, Protext, Prospell, Maxam, Utopia, all on Eprom the lot £50 or £10 per item. 40 Amsoft discs £25 or 10 for £7. Paal Kroeger, Berjevn.62, Tananger, Norway.

Protext Filer and Promerge (disc) unused and unwanted. Highlighted manuals, £20 each or £35 the two. Also available unused, Micro-Music Creator (First Byte), disc £12. Windsor (0753) 864803 evenings only.

Speak Esperanto (international second language) in over 100 countries! Textbooklet plus disc of 7 programs (4 self-testing) including two-language

vocabulary. £8.50 order now! Cheque/PO: B Russell, South Coast Road, Peacehaven, BN9 8QU

CF2 Printed labels £2.00/50, £3.50/100: Index cards for plastic disc-case £2.00/25, £3.00/50. Cheques to Mr S Tonks, Unit 106, 266-290 Wincolmllee, Hull, HU2 0PZ

Mono CPC 464, dust cover, two joysticks £115, modem and RS232 interface £40, computer table £15, sold together for special price of £150. Will deliver to buyer who lives locally. Tel: 01-310 9877.

Disc Backup Copier 100% success rate of tested titles, including Driller & Gauntler. Only £8 (£5 if you supply disc). Send cheques, PO's or SAE for details to Kevin McCaughey, 134 Donaghadee Road, Bangor, N.I. BT20 4NH.

Mono CPC464 disc drive, matrix spreadsheet, Pyraword, Stockmarket by Meridian, Discology, Joystick, many games, discs, TV modulator, seven software books, magazines £250 ono. Alan 0705 468357 Hampshire area.

CPC6128 home budget and accounting package. Fast, efficient, friendly. full range of facilities, 12 months accounts to each file. £12.50 or SAE for details. T Coard, Waes Hael, Bolnhurst, Beds. MK44 2EL.

CPC6128, colour monitor, tape deck, £400+ of original software, joystick, magazines, manual and CP/M discs. Worth £850, will sell for £420. Tel: (09278) 4286 after 6pm, weekdays only.

CPC6128 colour, printer, Rombo-rombox (Potext, Prospell, Promerge+, Discpower roms), books, firmware guides, magazines, software, PD software, Amsoft discs, 3.25" drive (powerless), Tasword 6128, Taspell, Art Studio, Mini Office, Pascal-80 etc. £650 including postage. Tel: (056587) 3176.

Romboard high quality 4 slot £12.50 + £1 P&P sent by return. Cheques or postal orders to T&M Services, Crossfield, Firhouse Road, Dublin 16, Ireland, or phone 0001 947552 for details.

Amstrad CPC6128 with colour monitor, joystick, over 50 games, magazines, all boxed and in excellent condition. Worth over £500. Sell for £200. Tel: (0843) 225107, ask for Ralph.

CPC 464 (colour), DD11, Multiface2, disks + box, joysticks, splitter, screen filter, dust covers, over 100 original games (Cyberoid, Nebulus etc), magazines, total value £1000, sell for £330. Phone Philip (04865) 5425.

Photofit can add, find, sort, match, describe all your photographs, send disc + £1 to N A Mower, 16 Woodroffe Close, Chelmer Village, Chelmsford, Essex CM2 6RS, phone 0245 469755 ask for Nathan.

Amstrad CPC serial interface kit. Link to Spectrum's, BBC's printers etc. complete kit including Circuit Board. Software on disc. All for £14.95. SAE G-Soft, 19 Meikle Crescent, Greengairs, Airdrie, ML6 7UQ.

CPC6128, colour, DMP2000 printer, 5.25" disc drive, desk, 4-way RFI-protected mains extension, discs + boxes, Amsoft manuals, books, accessories, worth £1000+, excellent condition, £750 ovno. Tel: Mr Swinnerton (Coventry) 0203 413552 evenings.

Loads of Public Domain software. No big adverts, so very cheap. Plus FREE games and utilities. Send SAE for details to: E Prattley, 30 Mellor Brow, Mellor, Blackburn, Lancs, BB2 7EX.

Hackers, tape-disc, disc-disc, disc-tape, disc editor, de-protect, speedlocks, disc cloning, handles Funny formats etc. Tape £8.00, disc £10.00. Cheques/POs or SAE for details. E Prattley, 30 Mellor Brow, Mellor, Blackburn, Lancs.

Amstrad Action issues one to six want-

WANTED

ed. Any reasonable price paid. Also Amsoft Space Hawks, Pitmans Typing Tutor and Mouse Trap (if made for the 6128?) Phone Mark, Letchworth 480674.

SERVICES

Eprom Services your own programs (Basic, Basic/Binary, Binary) programmed into eprom run using RSX commands (faster than discs!) from £9.95. Tel: (0438) 354908 (evenings), 25 Dovedale, Stevenage, Herts. SG2 9EP.

Convert your MP 1 or 2 modulator to give a 'Composit Video Signal Output' for direct connection to your video recorder - parts + instructions £6.99 to: A Talbot, 18 Trelawney Parc, St Columb Major, Cornwall, TR9 6RR.

Phoenix tape to disc specialist, NO 1 in conversions. Multiloaders no problem even Gryzor with Cheat Mode! State 464/6128, 85p per game, compilations 80p per game, multiloaders £3.50, add 30p for tapes to be returned if required. Enclose blank discs when ordering. Phoenix, 10 Walter St, Draycott, Derby, DE7 3DE. Tel: 03317 4490 after 7pm. If we can't disc it no one can.

USER GROUPS

CPC owners! United Amstrad user group offers a national network of help, advice, support. FREE PD library, bi-monthly magazine etc. £5 per year. Large SAE to: Gary Carter, UAUG, 1 Magnolia Close, Fareham, PO14 1PX.

OTHER

Make money with your micro, 84 page manual £9.00, includes setting up a computer services business! Cheques/PO's payable to Alan Moore, 6 Alma Terrace, Selby, North Yorkshire, YO8 0JY.

Stereo sound!! Special connector enables any Amstrad CPC to produce superb sound through a hi-fi. Only £4.95, cheque/PO (P&P included). Satisfaction guaranteed! Brad Reed, 56 Swaffham Road, Burwell, Cambridge, CB5 0AN.

This section of the magazine offers you the chance to speak directly to the huge waiting world of CPC owners - or would-be owners. Users report good results. You can place an ad of up to 30 words for just £5. So you could use it to sell a printer or launch a user group or publicize a piece of software you've written. One thing you can't advertise is the sale or swap of software. Such ads can be misused by pirates. Fill in the application form and send it to us together with payment. We'll then place the ad in the next available issue (published 2-7 weeks after we receive your order).

Order form Send to: AA Small ads, Future Publishing Ltd, 4 Queen Street, Bath BA1 1EJ

Please place the following advertisement in the next available issue of Amstrad Action

Name _____ I enclose payment of £5.00 by Cheque/P.O./Access/Visa.
 Address _____ Credit Card number _____
 _____ Credit card expiry date _____
 Telephone _____
 Classification: For Sale Wanted Services User groups Other _____

Write your advertisement here, one word per box. Include your name and phone no. if you want them printed

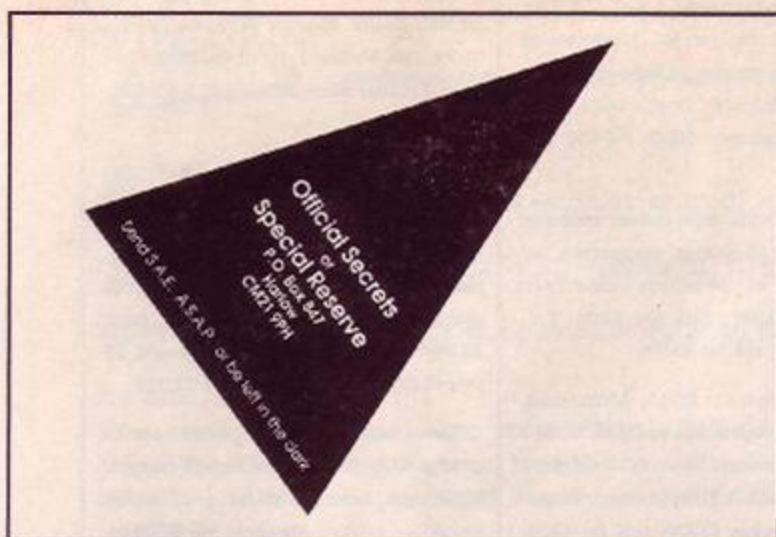

AMSTRAD COMPUTER REPAIRS

Fixed Price repairs

From £10 inclusive of VAT, P&P, and 3 months "NO QUIBBLE" guarantee
Send your computer to:-

The Computer Factory (Dpt.AA01),
Analytic Engineering Limited
Unit 18a, Grainger Road Industrial Estate,
Southend-on-Sea SS2 5DD

We will then give a no obligation fixed price quotation. If you want to proceed,
fine, if not, we will return the machine by the next post at our expense.

If you prefer to telephone in the first instance for an informal chat:-

TELEPHONE (0702) 618455

Also available, massive software selection

TELEPHONE (0702) 618455 for FREE LIST

Most computers are covered by our comprehensive deal. These include:-

SINCLAIR - COMMODORE - BBC etc.

TELEPHONE (0702)618455 for details

Skill.....Tactics.....Strategy.....Decisions.....Excitement.....Tension.....Action

FOOTBALL & CRICKET

QUALITY STRATEGY GAMES from E & J SOFTWARE (Established 1984)

EUROPEAN CHAMPIONS * NEW * - THE INTERNATIONAL CHALLENGE OF THE EUROPEAN NATIONS CUP - Genuine Nations Cup Format with full Random Draw of 32 Seeded Teams - Fixture List, Results and League Tables of ALL 8 Groups - Discipline & Medical Reports - Squad of 22 Players plus Other Players available - 17 Month Itinerary of Qualifying Group (Arrange Friendlies) and Finals - Plus many more Superb Features and Options. EUROPEAN CHAMPIONS includes E & J's MATCH PLAY SYSTEM an imaginative and exciting new style of match presentation which captures the ACTION, DRAMA & TENSION of International Football.

WORLD CHAMPIONS - A COMPLETE WORLD CUP SIMULATION - Select Friendlies - 25 Players - Qualifying Group - 2 In-Match Subs - Discipline Table - Select Tour Opponents - Extra Time - Final Rounds - Players Gain Experience - 7 Skill Levels - TEXT MATCH SIMULATION including: Bookings, Goal Times, Named & Recorded Goal Scorers, Injury Time, Corners, Free Kicks, Match Clock, Penalties - PLUS many more Features.

PREMIER II CAN YOU HANDLE ALL OF THIS? - Play all Teams Home & Away - Unique Transfer Market - Team & Substitute Selection - Named & Recorded Goal Scorers - Injuries - Transfer Demands - Continuing Seasons - Squad Listing ALL Teams Financial Problems - 7 Skill Levels - Offers to Manage other Teams - Sackings - Managers's Salary - Save Game - Team Styles - Bank Loans - AND many more Features.

EUROPEAN II - THE MOST COMPLETE SIMULATION OF EUROPEAN CLUB FOOTBALL YOU CAN BUY - Home & Away legs - Full Penalty Shoot-Out (with SUDDEN DEATH) - 2 In-Match Subs - Away Goals count Double (if Draw) - Full Team & Sub Selection - Extra Time - 7 Skill Levels - Enter your own PREMIER II Winning Team - TEXT MATCH SIMULATION plus Sending Off and Disallowed Goals - Results Table - PLUS MUCH MORE!

CRICKET MASTER - A SUPERB SIMULATION OF ONE DAY INTERNATIONAL/COUNTY CRICKET - Weather, Wicket & Outfield Conditions - Batting & Bowling Tactics - Team Selection - Fast, Medium & Spin Bowlers - 4 Types of Batsmen - Select Field Layout - 3 Skill Levels - Wides - Byes - No Ball - Run Out - Misfield - Dropped Catches - Scoreboard - Batting & Bowling Analysis - Run Rate - Single Option - 3 Game Speeds - STAR FEATURE a complete MATCH OVERVIEW showing Ball by Ball Action and Commentary and MUCH MORE!

TEST MASTER * NEW * A COMPREHENSIVE SIMULATION OF A 5 DAY TEST MATCH - includes most of the Features of CRICKET MASTER and MATCH OVERVIEW plus Declarations - Nightwatchmen - Light Meter - Rain Stops Play - Varying Number of Overs per Day - Follow On - Save Game - New Ball - Bad Light Interruptions - TEST MASTER is a True representation of a Complete Test Match and offers the ULTIMATE CHALLENGE to All Cricket Enthusiasts.

CRICKET MASTER & TEST MASTER prices include a FREE pad of SCORESHEETS

Software availability	Spectrum Any 48/128K		Commodore 64/128K		Amstrad CPC	
	Tape	Disc + 3	Tape	5 1/4" Disc	Tape	3" Disc
EUROPEAN CHAMPIONS	£7.95	£11.95	n/a	n/a	n/a	n/a
WORLD CHAMPIONS	£8.95	£10.95	£7.95	£10.45	£7.95	£11.95
PREMIER II	£6.95	£10.95	£7.95	£10.45	£7.95	£11.95
EUROPEAN II	£6.95	£10.95	£7.95	£10.45	£7.95	£11.95
CRICKET MASTER	£7.95	£11.95	£8.95	£11.45	£8.95	£12.95
TEST MASTER	£8.95	£12.95	n/a	n/a	n/a	n/a



FANTASTIC VALUE: Special Discount of £2.00 for every EXTRA game purchased (e.g. buy 2 Games deduct £2.00 from TOTAL - buy 3 Games deduct £4.00 from TOTAL - 4 Games £6.00 etc).

ALL GAMES are available by MAIL ORDER for IMMEDIATE despatch by 1st class post and include Full Instructions. (OUTSIDE UK please add £1.00 for postage and send payment in Pounds Sterling only)

PLEASE STATE WHICH MACHINE AND TAPE OR DISC. Cheques or Postal Orders payable to E & J Software.



Send to: E & J SOFTWARE, Room A1, 37 Westmoor Road, ENFIELD, Middlesex EN3 7LE.

WAGGI

THE WORLDWIDE AMSTRAD CPC USERS CLUB

THE SPECIAL OFFERS

	Rom	Disc	Cass		Price
				Rombo Rom Box	27.00
Protex	31.00	21.00	15.00	Vidi-CPC Digitiser	68.00
Prospell	27.25	19.50	-	464/664 Speech Synth Rom	39.95
Promerge Plus	27.25	-	-	6128 Speech Synth Rom	35.95
Promerge	-	19.50	-	10 x Amsoft CF2 Discs	23.95
Maxam	31.00	21.00	15.00	Protex Office Disk	27.25
Utopia	23.25	-	-	Maxam 1 1/2 Rom	23.25
Model Universe	-	15.00	12.00	BCPL Rom	23.25
CP/M+ Protex	-	47.00	-	Micro Music Creator Rom	19.95
CP/M+ Maxam II	-	39.00	-	Rombo Rom Box	27.00
CP/M+ Arnor C	-	39.00	-	Vidi CPC Digitiser	68.00
				TV Receiver/Tuner	65.95

DMP 2000 PRINTER RIBBONS£2.95

THE FANZINE

ANNUAL SUBSCRIPTION RATES

UK.....	£12.00
Europe.....	£18.00
Overseas.....	£24.00
Sample copy.....	£1.00

THE PUBLIC DOMAIN SOFTWARE

CPM DISC 1 - MACHINE CODE TOOLS	Price £6.50
Z80 and 8080 assemblers, Z80 to 8080 to Z80 code translator, Debugging monitor and assembler, Reverse assembler, Binary File comparer, plus NewSweep and more.	
CPM DISC 2 - COMPUTER LANGUAGES	Price £6.50
Small-C, Prolog, Lisp, EBasic, Small C-Interpreter plus NewSweep	
CPM DISC 3 - FILE AND DISC MANAGEMENT	Price £6.50
Library utilities, Disc quality checker, Unix GREP command, PCW disc reader, Disc sector editor, Text file sorter, Word counter, plus NewSweep and more.	
CPM DISC 4 - AT YOUR LEISURE	Price £6.50
Cave Adventure, Chess, Othello, Golf, Word search, Biorhythms, Maze generator, On-screen calculator, Prolog, Comms utility, plus NewSweep and more.	
CPM DISC 5 - THE BUSINESS	Price £6.50
Scrivener spreadsheet, Inventory database, Powerful text editor, Spelling checker with dictionary, Sorter, Word counter, Comms utility, plus NewSweep and more.	
CPM DISC 6 and 7 - PASCAL PLUS (Two Discs)	Price £10.00
Pascal, Sci, Cobol, EBasic, Powerful text editor, plus NewSweep.	

* ALL PROGRAMS COMPLETE WITH ORIGINAL DOCUMENTATION AND SUPPORT FILES*
SAVE MONEY * CPM DISCS 1 TO 5 FOR £29.95 - ALL 7 DISCS FOR £39.95 * SAVE MONEY

WACCI UK, 59 THE GREEN, TWICKENHAM, MIDDX TW2 5BU
EST. 1986 — PHONE 01-898 1090

PILGRIM

A special report on the state of CPC adventuring

Welcome, weary traveller! Whether thou hast been *dallying* in the Hall of the Mountain King, *tarrying* awhile with damsels fair, or simply *propping up* a wall in Lesser Codhampton, Berks, come now unto these pages with a clear heart and breathless anticipation of...

¶ software houses' adventure plans for 1988/9. Do they include us CPC owners?

¶ *Ye Clue Pot*, for those who be Stucke.

¶ *Ye Lords and Ladies of Adventure*, for those who be Truly Stucke and up to their Neckes in itte.

¶ And *ye Pilg Programming*, wherein those with grey cells have to get them workinge.

Software 1989 - CPC or bust?

It isn't so long ago that the Pilg did a round-up of adventure houses' plans for '88, and at that time the outlook definitely wasn't healthy. Following in the wake of **Mediagenic/Activision's** clamp-down on Amstrad **Infocom** releases, many companies were holding back from giving us the titles we deserve, the excuse being that the Amstrad CPC market no longer justified the expense.

Walloppes of ye cod! We know what to say to that! Just look what happens when a company actually takes the risk and goes ahead: **Electronic Arts** converted *The Bard's Tale* for CPC's and what happens? The sales astonish them so much that now they're considering further releases. The truth is that the Amstrad market has always been a very strong one for adventures and remains so. Now that some

shortsighted people are neglecting it there are some great opportunities for software houses to move in and give us something to play, making a profit in the process.

The good news is that this message may be sinking in. This month's round-up isn't nearly as pessimistic as the last one, and there are some very intriguing releases due out over the next six months. Here's the score...

St. Brides

Ever wonder what happened to our old friends **St Brides**? After a few very individual games released through various outlets they're now programming a game for another Activision associated label, **Destiny**, set up by ex-Beyond man **Francis Lee**. Called *King*, it's based on a poem by Mark Pearson and due for October release. It's a humorous (*sic*) tale of courage and valour (what adventure isn't?) in which hero Dog Boy takes on the King, a hideous beast, and leads his people to freedom. There's just one slight problem. There is considerable doubt whether it will make it onto the Amstrad. Watch this space.

Telecomsoft

Firebird recently released a very cute-looking icon-driven adventure on the ST called *Legend of the Sword* which raised the Pilg's hopes of further adventure software from this company and perhaps a release or two for the CPC. Alas, this is not to be.

What is on offer, though, is a new **Magnetic Scrolls** game. It certainly takes the biscuit in the strange scenario department. Called *Fish*, it celebrates the existence of a goldfish. Swimming around (upside down) in your aquarium, you discover the lost land of Aquaria, along with three mini-adven-

tures. You have to enter the land, where the water system is polluted, and put everything to rights.

Apparently a vital feature of *Fish* is its puns. The game is stuffed full of them: you encounter the **Seven Deadly Fins**, for example. Hmm... The Pilg is all for humour in games, but except for a couple of titles by **Infocom** and **Fergus McNeill**, I can't think of many that have been anything other than mildly embarrassing.

Meanwhile there has been the inevitable delay in getting CPC *Corruption* onto the shelves.

I've previewed this game, but look out for a full review.

Lancelot on the horizon...

Lancelot should be on the shelves by the time you read this. Launched at the **PC Show**, it's a title we should all be watching out for with a great deal of interest.

The reason is simple - this one of **Level 9's** more important releases, certainly the most significant since they launched their new adventure system with *Knight Orc*. *Lancelot* is a game in a more serious vein that could have a strength of plot missing from the company's recent titles and comes at a time when releases from other companies on contemporary (*Corruption*) or role-playing (*Bard's Tale*) themes are making the adventure/fantasy market more competitive than ever. **Level 9** badly need a Number One title to secure their reputation!



● *Lancelot* on the ST. Looks great, but CPC version still to be seen...

Activision

After the release of the so-so *Mindfighter*, **Abstract Concepts** are now hard at work on *Parisian Knights*. We don't have details at the moment but it should come out later this year and will be for both tape and disk CPC's. Expect some great graphics, and

hopefully some tweaks to the adventure system.

Mindfighter wasn't universally popular - The Pilg found it OK with one or two flaws - but fellow Pilgs should remember that it was AC's first release and they are bound to learn from experience. More news of *Parisian Knights* as we get it.

Level 9

Hats off to a company who may have had to resign a portion of their reputation in favour of newcomers **Mag Scrolls**, but who are now the only major adventure software house giving full support to Amstrad owners. Yeah!

Apart from *Lancelot* we're also promised *Ingrid's Back* (see news story in last month's column). **Pete Austin** goes further and says: The good news for Amstrad owners is that we are now publishing ourselves as well as

through **Mandarin** and we shall be putting out four titles a year, all of which are to be fully compatible with tape and disk CPCs. Give them a big hand (or *Gros Main*. The s, again, is silent).

Level 9's next release after *Ingrid's Back* is still a closely guarded secret, but The Pilg was able to ascertain that it is set in the 1950's. 'It's a serious adventure, a moody piece', reports Pete, and for a Pilgrim who's just a little fed-up with **Level 9's** reliance on fantasy rather than simply on fiction, this sounds encouraging.

Origin Systems

This company may not be known to fellow Pilgs, but I've included it because they've just released the superlative *Ultima V* for the PC and C64 and I was hoping they would be doing an Amstrad conversion. They're not.

The problem here is a common one and becoming increasingly prevalent in the UK. **Origin**, like **Activision**, **Electronic Arts** and **Microprose**, source a lot of their product in the States. There are no Amstrads in the States to speak of, so we don't get no games, OK?

No, it's not OK. It's understandable that an American programming outfit might not see any profit in supporting a minority

Incentive

In the old GAC days, **Incentive** were quite active in supporting the Arnold market. Unfortunately the games were of questionable quality - not poor, by any means, but not earthshakers either. They also started off rather expensive for games produced using a utility and, because of GAC, suffered fur-

ther by looking and playing in a similar fashion.

Sadly, however, the talk of an Advanced GAC turned into STAC - for the ST only - and since then the release of CPC games has dried up. Speaking for the company, **Ian Andrew** said that 'We would still release an adventure for the Amstrad if it was exceptional'. Some hope, then.

Mandarin

The Pilg caught **Mandarin** on the hop, it seems. There are no published plans for CPC adventures after *Lancelot*, but the message coming through loud and clear was that this is simply cloak-and-dagger policy and that the company are even now

rolling into action. Expect more Amstrad games from this label, whose message to is 'There are a lot of you out there, and we want to support you'. I'm sure they will and look forward to seeing what they've got to offer.

After *Time and Magik* and *Lancelot*, they have a high standard to keep up.

machine in a small country across the sea, but that's no reason why the companies concerned can't give the conversion work to a team of British programmers. Come on lads! **EA** did it with *Bard's Tale*, so why not an Amstrad *Ultima* - it would sell and sell!

Pilg programming lives!

First, a grovelling apology to all programming fans who've missed the series over the last three issues. The sad truth is that we never have all the time for all the things we want to do, or the space to fit them all in.

From now on, we'll be running our adventure programming course in every issue and printing new routines to add to your adventure as often as space permits. However, unlike other programming series, we won't simply be giving you lines of code to type in. Instead, we'll be designing 'command modules' that you can easily adapt for use in your own programs. Here's how it works (or is planned to...).

For each module, we first design a 'tree structure' (see AA's 21 and 24/25) that enables us to define the task concerned. We then code the structure and add into the program whatever data we want the module to operate on.

For example, we might want an **ATTACK** command. We first design the logic of this command, then code it, then enter into the program a series of messages that might need to be printed to the screen - 'Bash! Bang! Wallop!' for example, or 'You attack Cedric viciously with the axe'.

This month, however, we've going to start with something simple - the **GET** command. Here's a simple tree-diagram

showing a series of 'decisions' and their consequences that we want the program to make when we enter the **GET** command (see figure below).

You can see that the process involves testing a series of conditions, each of which is stored as a value by the program. The most frequently tested conditions are obviously going to be those encoded in the object's status byte, the structure of which was explained in A432 and which is stored as the second of the two values in line 6030.

Next month we print the routine that executes this command, and also a **DROP** tree-diagram and routine. In the meantime, can you design your own **DROP** diagram? And can you think of any modifications that enable you to produce your own version? It's worth trying to do this because we'll also be showing you exactly how to introduce a tree-design into the program, so that you can enter your own if you wish. Flexibility is the name of the game!

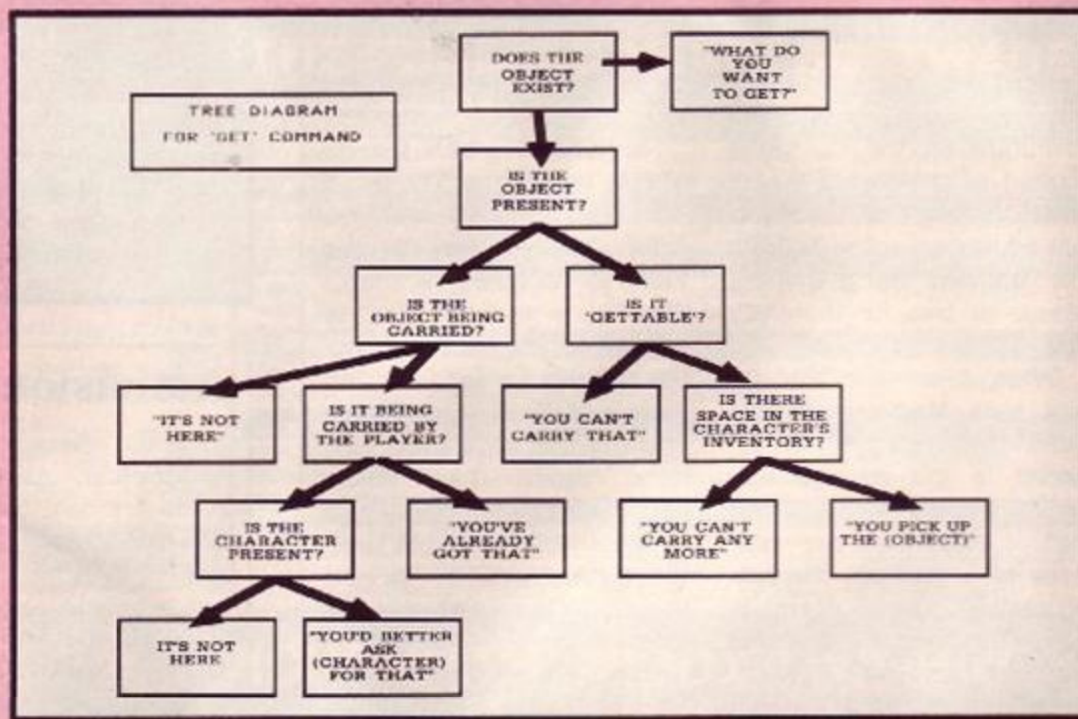

The Pilgrim's clue pot

So you're stuck, eh? Stick your nose into this lot and cheer up. Help this month comes from those renowned honorary Pilgs, Thomas Page and Chris Dowling. We're a bit short of space, but still have room to bring you the much-requested *Bard's Tale* tips (thank you, Thomas) and a host of tips on *Rigel's Revenge*.

The Bard's Tale

¶ The best party order is to put your warriors and paladins in the front row and the magic users, bards, and rogues behind.

¶ Most enemies can be defeated by the Bard using his fire horn. Only creatures like Golems are uninjured by this weapon – most are killed.

¶ It is best not to go into a dungeon unless your group is well armed.

¶ If you don't have access to a conjurer to deactivate traps to use the rogue.

¶ Monsters in the dungeons often leave treasure behind.

¶ Wait until you reach the higher levels before taking on more than 2 groups at once, especially if they include Orcs, Golems, or Barbarians.

¶ If you need money pool all your money to one character and remove the rest. Get a new set of characters and pool the gold to the original character. Do this several times and you will have loads of money. Then use the merger program to recreate your original party with the surviving one with the money.

¶ Spend your money on equipping the first 3 characters in order with the best weapons and armour as they are usually the ones who take the most punishment.

¶ Don't cast a spell at your own team using 1-6 instead of A!

¶ The Review Board is on Trumpet Street above the Inn.

Get your Revenge on Rigel's Revenge!

Start off by finding and wearing the goggles and examining Elleot. Pull the bars hard, remove suit, wear medikit, press red button (you feel strong) and bend bars. Remove medikit, put all through window, and get out.

Push the bed to get the 'shape' (empty stun gun), then buzz off and get the bone. Retrace your steps and give bone to dog. Press the green button, jump the gap, go down and get chased to a crossroads.

Press the dipswitch in the tank, get the mine detector and wear the headphones.

Wear the uniform, drop the suit, and turn the dial at a later stage before entering the crater. This helps you find the bomb, which threatens to blow up, but won't.

Turn the dial again and you set the detector for mines. When challenged by guards, say anything – this

wakes the bomb up and the introduce bomb to guards.

Part 2

Remove goggles, put them in the satchel, get the bomb, go north, drop the bomb, go south, and wait. Ooops! The bomb went off this time!

Charge your stun-gun by plugging it into the apparatus and then unplugging it again. There's a can under the bench.

The documents are in the seat – make sure you find and get the card which falls out of them...

Open and look inside the case found in the dustbin. Later, get past the android by spraying paint on the lens, so it can't see where it's going (remember Snowball by Level 9?).

The flare in the case can be used against the monster. Best of luck with the rest!

The Lords and Ladies of Adventure

You just don't deserve it. Why should these highly talented Pilgrims offer up prayers on your behalf? What's more, why should they go to the extreme lengths of writing into the Pilg with details of the games they've finished, prepared to help all comers?

The reason is these Lords and Ladies know the honour of being selected by the Pilg for this vital service is second only to the extreme pleasure they derive from communicating with fellow adventurers all around the world. Write to: **The Pilgrim, Amstrad Action, 4 Queen Street, BATH, BA1 1EJ.**

Forest at Worlds End, Gremlins, Heroes of Karn, Midnshadow, Message from Andromeda, Never Ending Story, Red Hawk, Spy Trek, Seabase Delta, SubSunk, Warlord, Spellbound, Knight Tyme, Storm Bringer.

Robert Weir, 87 Burnside Rd, Gorebridge, Midlothian, EH23 4ET

Beerhunter, Heroes of Karn, Never Ending Story, plus limited help on Redhawk and

Rigels Revenge.

Andrew MacDonald, Brookhouse Farm, Eccleshall, Staffs, ST21 6NE

Kentilla, The Big Sleaze, Hobbit, Forest at the Worlds End

David Liddell, 91 Orbiston Drive, Bellshill, ML4 2LX

Star Wreck, Lurking Horror, Pawn, Khobyashi Naru, Gems of Stradus, Forest at Worlds End, Jewels of Babylon, Message from Andromeda, Heroes of Karn, Aftershock, Warlord, Red Moon, Snowball, Hobbit, Necris Dome, Souls of Darkon, Lords of Time, Theseus, Robin of Sherlock, Buggy, Mordens Quest, Questprobe III, Very Big Cave Adventure, Boggit, Dodgy Geezers, Redhawk, Sorcerer, Hitchhikers Guide, Nythyhel, Brawn Free, Arnold Blackwood Trilogy, Fantasia Diamond, Espionage Island, Mindshadow, Inca Curse, Bored of the Rings, Emerald Isle, Spytrek, SubSunk, Hunchback, Seabase Delta, Never Ending Story, Knight Tyme, Circus, Sphinx Adventure, Woodbury End, Imagination, Stolen Lamp, Gremlins, Classic Adventure, Dungeons Amethysts, Alchemists 'n' Everything, Beer Hunter, Zork 1, Dracula, Colossal Adventure, Tomb of Kuslak, The Mural, Rebel Planet, The Forth Protocol, Enchanter, Lord of the Rings Pt 2.

Darren Stephens, 0795 73490

Seastalker, Hitchhikers Guide to the Galaxy, Lurking Horror, Leather Goddesses of Phobos, Souls of Darkon, Red Moon, SubSunk, Kaiser, Seabase Delta, Warlord, Heroes of Karn, Message from Andromeda, Forest at the Worlds End, Classic Adventure, Worm in Paradise, DAA'nEverything, Price of Magik, Return to Eden, Fantasia Diamond, Wildbunch and Experience. (Penpals also wanted)

Stuart Whyte, 53 Ridgeway Road, The Gables, Timperley, Altrincham, Cheshire, WA15 7HL

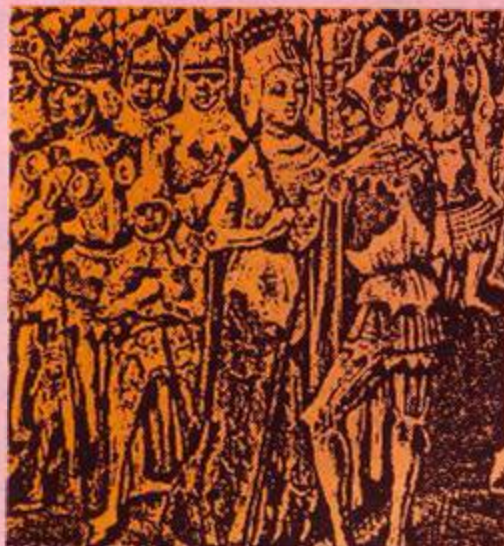





CHEAT MODE

The best tips, pokes and ploys to make life easier

Dark Side – the map

Michael Dickinson sent us this superb guide to Incentive's second Freescape epic. We passed it over to the art dept, and they turned Mike's map into this indispensable guide to the *Dark Side*!

Key

-  = ECD
-  = Prison sensor
-  = Plexor tank
-  = Telepod is here



THUNDERCATS

Elite's chop-em-up gets poked by Julian Page of Shrewsbury. Type in the poke, but leave out any lines that you don't want to use. RUN it with the disk in the drive.

```

1 'Thundercats - disk
2 'By Julian Page
3 'Amstrad Action Oct 88
4 'Leave out unwanted lines
5 'Don't remove lines 10-80
10 DATA 45,4C,49,54,45,2E,1A1
20 DATA 42,49,4E,21,4B,9B,1E0
30 DATA 36,09,C3,5F,85,21,207
40 DATA 80,BE,11,00,80,06,1D5
50 DATA 09,CD,77,BC,EB,CD,3C1
60 DATA 83,BC,E5,CD,7A,BC,427
70 DATA 21,AB,BE,22,12,09,1C7
80 DATA C9,0C9
90 'Death brings next level
100 DATA 3E,B9,32,04,81,1AE
110 '9 lives at start
120 DATA 3E,09,32,7A,78,16B
130 'No limit to extra lives
140 DATA 3E,FF,32,AB,79,293
150 'Lives bonus gives 9 lives
160 DATA 21,89,BE,11,A6,21F
170 DATA 79,01,08,00,ED,B0,21F
180 'Bonus always gives life
190 DATA AF,32,CA,9A,245
200 'Fewer creatures
210 DATA AF,32,3A,82,19D
220 'No creatures at all
230 DATA 3E,C9,32,51,81,20B
240 'Invulnerable to creatures
250 DATA AF,ED,62,32,E1,97,3A8
260 DATA 22,E2,97,32,54,9A,2BB
270 DATA 22,55,9A,111
280 'Invulnerable to Mumm-Ra
290 DATA AF,32,26,99,1A0
300 'Bonus Pts give laser gun
310 DATA 21,D4,9A,36,3E,23,226
320 DATA 36,03,23,36,77,ED,1F6
330 DATA 62,22,DA,9A,22,E1,9A,395
340 'LionO walks on water
350 DATA 3E,18,32,8A,7B,18D
360 'LionO floats after jump
370 DATA 3E,C3,32,01,7D,1B1
380 'LionO flies!
390 DATA ED,62,AF,22,85,2A5
400 DATA 7B,32,87,7B,1AF
410 'Do not remove!
420 DATA C3,D6,69,JPS
430 L=10
440 READ A$:IF A$="JPS" THEN
    GOTO 500
450 IF LEN(A$)<3 THEN 480
460 CK=VAL("&"+A$):IF CK<>C THEN
    GOTO 550
470 C=0:GOTO 440
480 V=VAL("&"+A$):POKE X,V
490 C=C+V:X=X+1:GOTO 440
500 MODE 1:CALL &BBFF
510 PRINT"INSERT DISC THEN"
520 PRINT"PRESS ANY KEY !!"
530 CALL &BB03:CALL &BB06
540 CALL &BE91
550 PRINT"DATA ERROR"

```

The black box

Most games are heavily protected these days, resulting in longer pokes.

Many of you have one of the infamous black boxes that can be used to stop programs - the **Multiface 2** from Romantic Robot for example.

Often the only thing that they're used for is transferring games from tape to disk, but they can also be used to hack games for infinite lives etc.

This new occasional section is for owners of the **Multiface 2** and similar devices so that they can poke games without typing in huge listings.

Here's how you enter them:

- Plug the **Multiface** into the expansion slot at the back of your keyboard. (**Multiface 2** owners: make sure that the switch on the front is in the up position.)

- Load the game that you want to poke in the usual manner following the instructions supplied with it. (**Multiface 2** owners: move the switch to the down position after it has loaded.)

- Press the red button on the **Multiface** and a menu appears at the bottom of the screen. Press 'T' for tool and then 'H' to change input to hexadecimal.

- Press the spacebar and type in the number under the Addr column. Next type in the number under the Poke column. Repeat this process until you've entered all of the pokes that are listed for the game and then press 'ESC'.

- Press 'R' to return to the game: it then runs with the pokes that you've just entered.

Game	Addr	Poke	Effect
<i>Arkanoid</i>	20f3	00	Inf lives
<i>Super R. Hood</i>	6c97	00	invulnerable
<i>Zynaps</i>	5f7e	ff	255 lives
	6139	c9	rapid fire
<i>Living Daylights</i>	2ced	00	Inf energy
	0727	02	level (01-08)
			02 for level 02
<i>Wizball</i>	a93a	a7	
	a92b	c3	Inf lives
<i>Scooby Doo</i>	7683	ff	Inf lives
<i>Freddy Hardest</i>	8afa	a7	Inf lives
<i>3D Starfighter</i>	7f3a	00	
	7f15	00	Inf shields
<i>Who Dares Wins 2</i>	631a	00	
	60c1	00	Inf lives
<i>Dark Side</i>	6f7b	a7	
	6e0a	a7	
	6580	18	
	6581	1b	Inf fuel+shields
	6e20	00	
	6e3e	00	Inf time
	7a19	00	
	7a1a	00	Stop ECD's regenerating

Note: a bracket | indicates that pokes are connected: e.g. on *Wizball* both a93a, a7 and a92b,c3 need to be entered to gain Inf lives. So on *Dark Side* you need to enter four pokes to gain Inf fuel & shields.

Win an ENTIRE ISSUE'S RAVES!

To win an entire issue's *Rave* software - and that includes the *Mastergame* - all you have to do is produce an excellent map, poke or set of playing tips.

The best solution each month wins a copy of every *Rave* and the *Mastergame* of that issue. The number of games varies of course, but in a good issue it can be half a dozen. We also give runner-up prizes every month of a *Rave* or the *Mastergame*.

This month's winner of the *Raves* and the *Mastergame* is Michael Dickinson for his excellent *Dark Side* map. The runners up who receive either a *Rave* or the *Mastergame* are Mike Wong and Julian Page. Well done chaps, you deserve it!



Julian Page of Shrewsbury has had a busy month's hacking. This time the tape version of Ocean's arcade conversion gets the treatment. (Method 1.)

```

1 'Gryzor - Disc
2 'by Julian Page
3 'Amstrad Action Oct 88
10 DATA DD,7E,00,32
20 DATA 00,BE,21,2E
30 DATA A1,0E,07,CD
40 DATA D4,BC,22,2F
50 DATA A1,21,85,1C
60 DATA 11,00,00,0E
70 DATA 42,DF,2F,A1
80 DATA D5,11,00,02
90 DATA 19,D1,0C,DF
100 DATA 2F,A1,21,A8
110 DATA 1C,01,A0,03
120 DATA 3E,20,16,ED
130 DATA F5,AE,AA,77
140 DATA 57,14,23,0B
150 DATA 78,B1,28,07

```

```

160 DATA F1,C6,0D,E6
170 DATA 7F,18,ED,21
180 DATA BB,1C,F1,01
190 DATA 8D,03,3E,41
200 DATA F5,AE,77,23
210 DATA 0B,78,B1,28
220 DATA 07,F1,C6,0B
230 DATA E6,7F,18,F0
240 DATA F1,21,C8,1C
250 DATA 01,7E,03,35
260 DATA 23,0B,78,B1
270 DATA 20,F9,21,E9
280 DATA 1C,01,5F,03
290 DATA 3E,1B,F5,AE
300 DATA 77,23,0B,78
310 DATA B1,28,07,F1
320 DATA C6,09,E6,7F
330 DATA 18,F0,21,33
340 DATA 1D,F1,01,15
350 DATA 03,3E,4C,CD
360 DATA 18,A1,21,63
370 DATA 1D,01,E5,02
380 DATA 3E,45,CD,18
390 DATA A1,21,71,1D
400 DATA 01,D7,02,34

```

```

410 DATA 23,0B,78,B1
420 DATA 20,F9,3E,2B
430 DATA 21,8D,1D,01
440 DATA BB,02,F5,AE
450 DATA 77,23,0B,78
460 DATA B1,28,07,F1
470 DATA C6,09,E6,7F
480 DATA 18,F0,21,FF
490 DATA 1D,11,55,A8
500 DATA D5,01,49,02
510 DATA F3,ED,B0,21
520 DATA D2,A0,22,D3
530 DATA A8,C9,3A,00
540 DATA BE,47,CB,40
550 DATA 28,05,3E,B7
560 DATA 32,26,15,CB
570 DATA 48,28,04,AF
580 DATA 32,66,05,CB
590 DATA 50,28,04,AF
600 DATA 32,57,18,CB
610 DATA 58,28,0E,3E
620 DATA 18,32,31,0E
630 DATA 21,00,00,22
640 DATA BD,10,22,C3
650 DATA 10,CB,60,28
660 DATA 05,3E,18,32
670 DATA 01,17,21,76
680 DATA 19,36,4A,23
690 DATA 36,2E,23,36
700 DATA 50,C3,19,04
710 DATA E5,D1,F5,AA
720 DATA 96,AB,77,23
730 DATA 0B,78,B1,28
740 DATA 07,F1,C6,0E

```

```

750 DATA E6,7F,18,EE
760 DATA F1,C9,84,00
770 DATA 00,07,00,42
780 FOR X=&A000 TO &A132
790 READ A$:A=VAL("&"+A$)
800 POKE X,A:C=C+A
810 NEXT X
820 IF C=&70BD THEN 840
830 PRINT"CHECK DATA.":END
840 C=1:X=0:DEFSTR A,B
850 A="INFINITE LIVES"
860 GOSUB 1010
870 A="NO TIME-OUT"
880 GOSUB 1010
890 A="NO WALL BLASTERS"
900 GOSUB 1010
910 A="INVULNERABILITY"
920 GOSUB 1010
930 A="WRAP-ROUND FIRE"
940 GOSUB 1010
950 PRINT"INSERT GRYZOR"
960 PRINT"DISC , PRESS"
970 PRINT"ANY KEY."
980 CALL &BB03
990 CALL &BB06
1000 CALL &A000,X
1010 CLS:PRINT A:B=""
1020 WHILE B=""
1030 B=INKEY$:WEND
1040 B=UPPER$(B)
1050 X=X OR C*ABS(B="Y")
1060 C=C*2:RETURN

```

Outrun

Mike Wong of Sale has poked US Gold's racing game for infinite time or a longer time limit. Type in the poke and then RUN it with the Outrun disk in the drive.

```

1 ' Outrun-disk
2 ' by Mike Wong
3 ' Amstrad Action Oct 88
10 MODE 2:MEMORY &7FFF:z=270
20 FOR n=&8000 TO &8120
STEP 16
30 FOR p=0 TO 15
40 READ a$:b=VAL("&"+a$)
50 POKE n+p,b:c=c+b
60 NEXT:READ x$
70 d=VAL("&"+x$)
80 IF c<d THEN 260
90 z=z+30:c=0:NEXT
100 INPUT"Infinite time (y/n)":a$
110 IF a$="n" THEN 140
120 POKE &80E1,&37
130 POKE &80E2,&30:GOTO 240
140 INPUT"How many seconds
(0-99)":a
150 IF a>10 THEN 190
160 POKE &80E1,&30
170 POKE &80E2,a+&30
180 GOTO 220
190 a$=STR$(a)
200 POKE &80E1,&30+
VAL(MID$(a$,2,1))

```

```

210 POKE &80E2,&30+
VAL(RIGHT$(a$,1))
220 FOR n=&80D0 TO &80DF
230 POKE n,0:NEXT
240 PRINT"Insert OUTRUN
disc...":CALL &BB18
250 CALL &8000:END
260 PRINT"Error in line";z;"-
";z+20:END
270 DATA cd,1c,81,21,0c,80
280 DATA 22,14,01,c3,00,01
290 DATA 31,fa,bf,cd,5c9
300 DATA ee,80,21,85,1c,0e
310 DATA 23,cd,06,81,3e,4c
320 DATA 32,a2,4c,32,591
330 DATA a5,4c,3e,c3,32,fd
340 DATA 4f,21,2d,80,c3,10
350 DATA 81,21,a8,1c,677
360 DATA 0e,13,cd,06,81,3e
370 DATA 4c,32,ba,4c,21,40
380 DATA 80,c3,10,81,56c
390 DATA 21,bb,1c,0e,0e,cd
400 DATA 06,81,3e,4c,32,c7
410 DATA 4c,21,53,80,52b
420 DATA c3,10,81,21,61,80
430 DATA 22,e7,1c,3e,56,21
440 DATA d5,1c,c3,19,5fd
450 DATA 81,21,6f,80,22,2e
460 DATA 1d,3e,7a,21,0e,1d
470 DATA c3,19,81,21,480
480 DATA 7d,80,22,5e,1d,3e
490 DATA 21,21,3e,1d,c3,19
500 DATA 81,21,63,1d,473

```

```

510 DATA 0e,0d,cd,06,81,3e
520 DATA 4d,32,6e,4d,21,96
530 DATA 80,22,fe,4f,58d
540 DATA 21,39,20,c3,63,4d
550 DATA 21,7c,1d,0e,11,cd
560 DATA 06,81,3e,4d,4a5
570 DATA 32,8c,4d,21,b1,80
580 DATA 22,fe,4f,3e,61,21
590 DATA 7c,4d,c3,19,631
600 DATA 81,21,aa,1d,11,80
610 DATA a9,01,8f,02,ed,b0
620 DATA 21,80,be,22,653
630 DATA 5c,aa,21,d0,80,11
640 DATA 80,be,01,1a,00,ed
650 DATA b0,c3,d5,a9,7bf
660 DATA 21,ae,20,36,00,23
670 DATA 36,00,23,36,00,21
680 DATA 23,21,36,18,28a
690 DATA 21,39,39,22,96,03
700 DATA c3,00,01,53,50,c3
710 DATA 00,01,21,85,41f
720 DATA 1c,11,85,6c,01,c0
730 DATA 03,ed,b0,c9,21,85
740 DATA 6c,11,85,1c,60c
750 DATA 01,c0,03,ed,b0,c9
760 DATA 06,00,7c,c6,30,57
770 DATA 5d,ed,b0,c9,7bc
780 DATA 22,fe,4f,cd,fa,80
790 DATA c3,85,4c,ed,4f,e9
800 DATA 21,00,01,11,7a2
810 DATA 00,00,0e,41,df,28
820 DATA 81,c9,3c,c0,07,00
830 DATA 00,00,00,00,3a3

```

Dark Side

The theme continues as AA34's *Mastergame* is hacked by Mike Wong of Sale to give you infinite fuel, shields, time and to prevent the ECD's from regenerating. (Method 1.)

```
1 ' Dark Side-tape
2 ' by Mike Wong
3 ' Amstrad Action Oct 88
10 OPENOUT"d":MEMORY &F9F
20 CLOSEOUT:LOAD"DARKSIDE"
30 POKE &1002,&E1
40 POKE &1003,&C9
50 n=&BE80
60 READ a$:IF a$="*" THEN 90
70 POKE n,VAL("&"a$)
80 n=n+1:GOTO 60
90 CALL &FA0:CALL &BE80:END
100 'INFINITE SHIELDS & FUEL
110 DATA 3e,a7,32,7b,6f,32
120 DATA 0a,6e,21,18,1b,22
130 DATA 80,65
140 'INFINITE TIME
150 DATA af,32,2d,6e,32,3e
160 DATA 6e
170 'PREVENT ECDs REGENERATING
```

```
180 DATA 21,00,00,22,19,7a
190 REM LEAVE
```

```
200 DATA c3,62,1c,*
210 END
```

Mike Wong's poke has been adapted to run with the disk version of Incentive's game. Type in the poke and RUN it with the *Dark Side* disk in the drive.

```
1 ' Dark Side-disk
2 ' Amstrad Action Oct 88
10 MEMORY &3FFF
20 LOAD"dark",&4000
30 DATA 3e,c9,32,0b,40,cd
40 DATA 00,40,af,32,81,00
50 DATA cd,51,00
60 'Infinite Shields & Fuel
70 DATA 3e,a7,32,7b,6f,32
80 DATA 0a,6e,21,18,1b,22
90 DATA 80,65
100 'Infinite Time
110 DATA af,32,2d,6e,32,3e
120 DATA 6e
130 'Prevent ECD's regenerating
140 DATA 21,00,00,22,19,7a
150 'Leave next line
```

```
160 DATA c3,62,1c
170 FOR n=&BE80 TO &BEAC
180 READ a$
190 a=VAL("&"a$)
200 POKE n,a
210 NEXT n
220 CALL &BE80
230 END
```

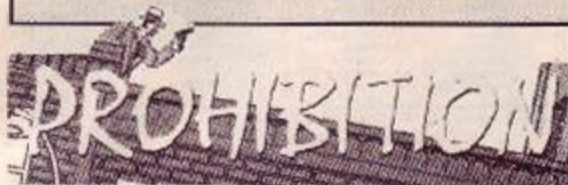

The cassette version of Infogrames shoot-em-up is another on the Julian Page hit list. (Method 1.)

```
1 'Prohibition-tape
2 'By Julian Page
3 'Amstrad Action Oct 88
10 DATA 21,0D,40,11
20 DATA 40,00,D5,01
30 DATA 64,00,ED,B0
40 DATA C9,DD,7E,00
50 DATA 32,00,00,11
60 DATA 80,3F,21,00
70 DATA C0,E5,CD,A0
80 DATA 00,21,E6,00
90 DATA 11,00,40,D5
100 DATA CD,A0,00,D1
110 DATA D5,E1,CD,A0
120 DATA 00,21,00,80
130 DATA 11,00,20,D5
140 DATA CD,A0,00,D1
150 DATA E1,E5,D5,CD
160 DATA A0,00,F3,C1
170 DATA E1,11,00,A0
```

```
180 DATA ED,B0,3A,00
190 DATA 00,47,CB,40
200 DATA 28,0B,21,69
210 DATA 0B,36,00,23
220 DATA 36,18,23,36
230 DATA 01,CB,48,28
240 DATA 04,AF,32,8E
250 DATA 19,CB,50,28
260 DATA 05,3E,B7,32
270 DATA B1,0F,C3,75
280 DATA 09,AF,C3,A1
290 DATA BC,00,00,00
300 FOR X=&4000 TO &4073
310 READ A$:A=VAL("&"A$)
320 POKE X,A:C=C+A
330 NEXT X:MODE 1
340 IF C=&2B8 THEN 360
```

```
350 PRINT"DATA ERROR":END
360 C=1:X=0:DEFSTR A,B
370 A="INFINITE LIVES"
380 GOSUB 460
390 A="GUNMEN CAN'T FIRE"
400 GOSUB 460
410 A="ENDLESS HIDE-TIME"
420 GOSUB 460
430 INK 0,3:INK 1,26
440 INK 2,13:INK 3,0
450 CALL &4000,X
460 CLS:PRINT A:B=""
470 WHILE B=""
480 B=UPPER$(INKEY$)
490 WEND
500 X=X OR C*(B="Y")
510 C=C*2:RETURN
```

POKE METHODS ON TAPE

Here's how to input most *Cheat Mode* tape pokes - the instructions for each poke tell you which of the two to use. 664 and 6128 owners: first type 1 tape.

METHOD 1

Rewind the game tape to the beginning, type in the poke listing and then type RUN and press the Enter key. (Don't use the key marked CTRL or Control, or the poke won't work.) Press the Play key on the cassette deck, then any key on the main keyboard - spacebar does nicely. The tape should now play through as normal.

METHOD 2

Skip the first bit of the game program. To do this, rewind the game tape to the beginning; type in the listing; now type CAT and press Enter. Start the tape by pressing Play and then any key. Soon you'll see the message: "Found something Block 1". It doesn't matter what the something is, and it varies from game to game. If the *Cheat Mode* instructions just tell you to skip the first block, stop the tape here.

If the instructions tell you to skip things, stop the tape when the "Found" message comes up for the last thing you're trying to skip.

Once you've stopped the tape, press Escape, type RUN and press Enter. Now press Play on the tapedeck and any key on the keyboard to start the tape.

Shorten the odds

- We receive dozens of pokes, and the ones published tend to be on cassette or disk, unless they're very short (get the hint?).
- Include an SAE if you want your disk or tape returned.
- Make sure your name and address is on everything you send us!

SPEEDYSOFT

The Fastest Mail Order Service Available

AMSTRAD CPC

Cassette £1.00	Software Star	Mutants
Alien Highway	Happy Letters	Hijack
Voodoo Rage	Happy Numbers	Triaxos
Skyfox	Grid Iron	Mystery of the Nile
Tir Na Nog	Dark Wulde	ONE
Colony	Dawnsley	Ninja
Master Chess	Werewolf Simulator	Room Ten
LA SWAT	Splat	Dragons Lair
Five Quadrans		Escape from Singes Castle
Molecule Man		Yie Ar Kung Fu 2
How to be a hero	Zaq	Hybrid
Spook School	Martianoids	Costa Capers
Radzone	Explorer	Jack The Nipper 2
Chiller	Galvan	Bridge Player
Fly Spy	Equinox	Terminus
Destructor	Zapp	Storm Bringer
The Fear	Genius	
Strike	Shogun	
Video Poker	Giroscope	
Bosconian	Starquake	
Nonterraqueous	Warzone	
Kobyashi Naru	Zorro	
One Man And His Droid	Bounder	
Finders Keepers	Technician Ted	
Xcel	Devils Crown	
Chronos	Super Sleuth	
Fiend	Redhawk	
Kane	Matchpoint	
Jackel and Wilde	Dun Durach	
Rastaerscan	Knightmare	
Soul of a Robot	Marsport	
Venom	Osprey	
Invasion	Prodigy	
Pipeline		
Jeff C. Strong Man		
Agent X 2		
Fantastic Voyage		
Superchess		
Formula One Simulator		
Skaterock		
Dan Dare		
Ghostbusters		
Nightshade		
Dambusters		
Sweevos World		
Defend or Die		
Wizard Lair		
Confusion		
Beachhead		
	Deactivators	Tapper
	Short Circuit	Room Ten
	Convoy Raider	Zoids
	Frankenstein	T.L.L.
	Basket Master	Hacker
	krakout	Jailbreak
	Samurai Trilogy	Druid
	The Final Matrix	The Hive
	West Bank	Spy V Spy Island Caper
	Highlander	Shockway Raider
	Ninja Hampster	Xaq
	Sepulcri	Saracen
	Werner	Prodigy
	Shadowfire	Barry McGuigan Boxing

£1.50

£3.00

£2.00

Disc Software
£3.50

GALEPER SOFT PRESENT:

POKE-EASY PLUS+. Surely, the ultimate in Hacking Programs! Look at the exclusive features POKE-EASY PLUS+ has to offer:

- ★ POKE EASY PLUS+ can easily search through most Tape/Disc Games for infinite lives, POKEs, start at any level, etc, as found in CHEAT MODE! SpeedLock'ed and heavily protected games included!
- ★ A comprehensive Tape-to-Disc, Disc-to-Disc, etc, transfer utility which copies so many games. Includes the devastating POWER BACKUP!
- ★ It has included a DJL SpeedLock Blaster, for games such as COBRA, ARKANOID, GRAND PRIX SIMULATOR, HEAD OVER HEELS, SHORT CIRCUIT etc and most others that load with the distinctive DJL flashing border.
- ★ There is a Slow Motion mode, and Pause facility for many games!
- ★ Faster saving of programs onto Tape with the TURBO Option.
- ★ No programming knowledge is needed to operate POKE-EASY PLUS+.
- ★ It also has a useful VIEW TEXT facility to find hidden messages!
- ★ And it's only £10.95 on Cassette, or £15.95 on Disc. Absolutely no self-respecting Games-player should be without it!

(Add £1.00 for Air Mail overseas, please!)

★ Cheques/POs to GALEPER SOFT, AMS Dept.,
36, WESTON LANE, BRIDGETOWN, TOTNES, S. DEVON, TQ9 5UN.
Tel: (0803) 864784. An exclusive offer!

SAE For Lists budgetsoft

(GPC/PCW and PC1512)

<p>£1.95</p> <p>CLASSIC ADVENTURE 30 BRADERS MURDER OF THE LAMPS PORTING WARRIOR RAIDER DANGER WOLFE IN DEL TRO SPIT PERSONALITIES SOFTWARE STAR CHOPPER SQUAD SCENE ON ICE TRANS-ATLANTIC BALLOON</p> <p>£3.95</p> <p>THE CLIP FOOTBALL FA CLIP FOOTBALL II SCREEN PLAY WAGE WORLD CLIP GARDEN BEAR BRAND BOING JACKS SUPERSTAR CHALLENGE INTERNATIONAL KICKY WALL DIVERS FOOTBALL MANAGER PRESS GYM FUTURE FIGHT CRUISE HILL IMPOSSIBLE REPAIR INTERNATIONAL GATE MONEY SHOOTER</p> <p>£2.95</p> <p>MEGACRATOR RALLY DRIVER LASER BUMP HACKER II GOLF CAPES STRONG MAN ACTUAL GREAT SPEED EDGE WARRIOR</p>	<p>£4.95</p> <p>THIRD OF THE EFFING TANK BLAZER KANA KAMA THE FOURTH PRODIGE ALIENS BIRTH SQUAD THREE NEEDS IN PARADISE STARBUCK NOW CAMP 2 JET SET MILLY MAD MADORE GENISS LAWYER SUPERLEUTH SUPERCHESS MURDER'S GUEST REPORT GENERATOR EAT TASTIC SAB NO BIG TROUBLE IN LITTLE CHINA BALLBLAZER HACKER ACTION PACK I JANE SHERIDAN HERESS 30 SCAND 30 STUNT IN DEP SUPERSTAR WYPER POLYMER S.A.S.</p> <p>£5.95</p> <p>QUARTZ SUPER SPY RAY-WAY STAR FALLS 2 ACE MYSTERY OF NA BOGLES SPYING IN TOWERS OF DEEP SULLIVAN'S KEY BYZAN TRANZON SPYWARE WAR II BLAZE PIONEER TARGET</p>	<p>£6.95</p> <p>SPACE WARRIOR WALLS BRICK NEW GAMES II PING PONG MICRO FALLS GAMES I CHOPPER SQUAD CHOPPER SQUAD 2 MOPEDRIVE VOL 2 WAY OF THE TIGER TR AN KUNG FU STAR GAMES ONE BETRO NIGHT RIDER WATER SPORTS SPACE SHUTTLE KUNG FU WARRIOR GALYAN GALYAN II ACTION PACK II MICRO FALLS 2 SACOWBAT JEWELS OF DARKNESS WELTROT ROAD RUNNER WINTER GAMES ROCKY HUNTER SHOULDER SPACE WARRIOR ROADRACE DONS JACK LEGGE THROATCAT I (SAC) QUARTZ (SAC) MIDNIGHT TARDIS (SAC) KUT WEEGUMEN MONTH INTERNATIONAL KARATEDO FIVE F ADDLES (SAC) FUB GRUBB (SAC) DUMPFY BREAD SHEET TEACH YOURSELF BASKETBALL FEELING TRIAL RUSSET FOOTBALL MANAGER I</p>
---	--	--

Post and packing: 1-3 titles 75p, 4 or more £1. Overseas £1.30 per title
PERIPHERALS: £1 per item. Overseas £1.60
Please send cheques/POs to: Budgetsoft, Dept AA, 33 Little Breach,
Chichester, W Sussex, PO19 4TY.

- * Established five years we offer unrivalled prices and Service
- * TO ORDER: Send cheque or postal order made payable to: SPEEDYSOFT
15 LADY BYRON LANE
KNOWLE, SOLIHULL
W.MIDS B93 9AT
- * Credit card orders welcome by phone on 0564 55975
Mon-Friday 9.30-6.00/Sat 9.30-12.30: We accept Visa, Access, Mastercard & Eurocard

Name.....Comp Type.....
Address.....
.....
.....
.....

Visa/Access/Mastercard/Eurocard
Card No.

Title	Price
1.	
2.	
3.	
4.	
5.	
Post & Packing	£1.00
Grand Total	

Please use separate sheet for more titles.

Matrix Software Hire

The cheapest way to play them all.

Top games titles for Amstrad, Commodore and Spectrum

Disc and Tape for Amstrad and Commodore.

Please state system

Please send large SAE for details to

Matrix Leisure Club, Dept AA,
271 Stansted Road, Bishops Stortford
Herts CM23 2BT

AMSTRAD RECOMMENDED REPAIR CENTRE

For guaranteed repairs to Amstrads – BBCs – Commodores – Sinclair QLs – Spectrums – and many other makes of popular home and business computers, printers & disk drives.

Sale of ancillary equipment.

Many second hand computers bought and sold.

Free Estimates.

MANCOMP LTD

Phone

061-224-1888 or 061-224-9888

for details

AA Games Index

Every review 1-36

TITLE	PRODUCER	1) RATING	2) ISSUE	3) PAGE
-------	----------	-----------	----------	---------

10 COMPUTER HITS: 2	BEAU JOLLY	63	9	56
10TH FRAME	US GOLD	60	19	60
180	MASTERTRONIC	67	17	63
2112 AD	DESIGN DESIGN	73	9	46
3D BOXING	AMSOFT	66	3	47
3D CLOCK CHESS	CP SOFTWARE	90	9	64
3D GRAND PRIX	AMSOFT	87	3	38
3D INVADERS	AMSOFT	20	1	80
3D QUASARS	SOLAR SOFTWARE	38	4	44
3D STARSTRIKE	REALTIME GAMES	86	1	80
3D STUNTRIDER	AMSOFT	57	2	73
3D TIME TREK	ANIROG	30	1	75
5 A SIDE SOCCER	MASTERTRONIC	17	14	56
500CC GRAND PRIX	ACTIVISION	42	19	58
720	US GOLD	69	28	53



A VIEW TO A KILL	DOMARK	67	2	47
ACADEMY TAU CRT 2	CRL	94	19	46
ACE	CASCADE	54	18	46
ACE OF ACES	US GOLD	50	21	49
ACROJET	US GOLD/MPROSE	99	18	40
ACTIVATOR	CASCADE GAMES	95	15	62
ADMIRAL GRAF SPEE	AMSOFT	38	1	74
ADVAN. TACT. FIGHTER	DIG INTERGRATION	94	31	42
ADVS OF BAS. BOND	PROBE SOFTWARE	63	10	56
AGENT ORANGE	ANF	65	19	52
AGENT X 2	MAD	38	28	64
AHHH!!!	CRL	44	1	61
AIR TRAFFIC CONTROL	HEWSON C	68	1	62
AIRWOLF	AMSOFT/ELITE	78	1	94
ALADDIN'S CAVE	ARTIC	55	5	60
A. HIGGINS SNOOKER	AMSOFT	54	1	74
A. HIGGINS WORLD POOL	AMSOFT	51	1	68
ALIEN	AMSOFT	65	1	76
ALIEN 8	ULTIMATE	96	1	57
ALIEN BREAK IN	AMSOFT	43	1	72
ALIEN HIGHWAY	VORTEX	89	9	48
ALIENS	ELECTRIC DREAMS	55	28	63
ALIENS	ELECTRIC DREAMS	90	17	48
AMAUROTE	MASTERTRONIC	85	22	44
AMAZING SHRINK. MAN	INFOGRAMES	68	20	49
AMAZON ADVENTURE	INFOGRAMES	37	32	55
AMERICAN FOOTBALL	AMSOFT	70	1	67
AMERICAS CUP CHALL.	US GOLD	62	17	69
AMSGOLF	AMSOFT	67	1	68
AMSTRAD SHUFFLE	ALPHA-OMEGA/CRL	68	12	57
ANARCHY	HEWSON	74	29	56
ANDROID 2	VORTEX	75	2	48
ANDROID ONE	VORTEX	65	1	60
ANDY CAPP	MIRRORSOFT	60	30	54
ANIMATED STRIP POKER	KNIGHTSOFT	52	1	81
ANNALS OF ROME	FSS	74	17	72
APPRENTICE	MASTERTRONIC	78	14	58
ARCTIC FOX	ELECTRONIC ARTS	81	35	40
ARGO NAVIS	KUMA	81	3	47
ARKANOID	IMAGINE	88	22	54
ARKANOID-REV. OF DOH	IMAGINE	83	32	50
ARMAGEDDON MAN	MARTECH	61	26	48
ARMY MOVES	IMAGINE	58	22	58
ARNHEM	CCS	75	1	47

ASPHALT	UBISOFT	80	21	62
ASSAULT ON FORT STAN.	AMSOFT	58	4	66
ASTERIX	MELBOURNE HOUSE	51	17	72
ASTRO ATTACK	AMSOFT	38	1	62
ASTRO PLUMBER	BLUE RIBBON	48	6	65
ATLANTIS	ANIROG	46	5	44
ATOM SMASHER	AMSOFT	33	1	72
AUF WIEDERS. MONTY	GREMLIN	71	22	49
AVENGER	GREMLIN	83	16	80

B

BACK TO REALITY	MASTERTRONIC	81	16	73
BACTRON	ACTIVISION	80	16	84
BAD CAT	US GOLD	85	32	48
BALL BREAKER	CRL	69	20	57
BALL CRAZY	MASTERTRONIC	85	23	50
BALLBLAZER	ACTIVISION	71	21	54
BALLOON CHALLENGE	VIRGIN	53	24	58
BARBARIAN	PALACE	67	23	42
BARCHOU	CENT SOLNS.	21	7	67
BARD'S TALE	ELECTRONIC ARTS	90	36	36
BARRY MCGUIGAN'S BOX	ACTIVISION	86	5	54
BASEBALL	ACTIVISION	47	25	48
BASIL MOUSE DETECT.	GREMLIN	70	29	48
BASKET MASTER	IMAGINE	65	29	52
BATMAN	OCRA	93	8	49
BATTLE BEYOND STARS	SOLAR SOFTWARE	62	4	40
BATTLE FIELD GERMANY	PSS	78	11	60
BATTLE FOR MIDWAY	PSS	59	1	88
BATTLE OF BRITAIN	PSS	81	3	66
BATTLE OF PLANETS	MIKRO-GEN	64	7	55
BATTLEFRONT	CEN.SOLUTIONS	44	7	61
BATTLESHIPS	ELITE	63	36	44
BCS FOOTB. FORTUNES	CDS	73	19	80
BEACH HEAD	US GOLD	82	4	62
BEACH-HEAD	US GOLD	82	1	46
BEACH-HEAD 2	US GOLD	42	15	63
BEDLAM	US GOLD	53	30	49
BELLS	BLABY	40	5	40
BEYOND ICE PALACE	ELITE	77	33	37
BIG LEAGUE SOCCER	ADAM WHITLOCK	82	3	38
BIG LEAGUE SOCCER 2	VIPER	85	7	72
BIGGLES	MIRRORSOFT	81	11	49
BINKY	SOFT. PROJECTS	60	1	78
BJ'S STAR CHALLENGE	MARTECH	67	2	42
BLACK MAGIC	US GOLD	47	25	48
BLADERUNNER	CRL	60	11	59
BLAGGER	ALLIGATA	61	1	69
BLOCKBUSTERS	DOMARK	47	30	48
BLOCKBUSTERS	MACSEN	14	7	71
BLOOD BROTHERS	GREMLIN	62	34	43
BLOOD VALLEY	GREMLIN	35	32	48
BLUE WAR	GO	61	28	62
BMX SIMULATOR	CODE MASTERS	68	21	60
BOB WINNER	LORICIELS	60	31	56
BOBBY BEARING	THE EDGE	76	17	59
BORSLEIGH	DIGIT INTEGRATION	91	29	42
BOMB JACK	ELITE	84	10	62
BOMB JACK 2	ELITE	91	19	50
BOULDERDASH	MIRRORSOFT	93	1	18
BOULDERDASH CKIT	DATABYTE	70	29	56
BOUNDER	GREMLIN	92	9	58
BOUNTY BOB STRIKES	US GOLD	84	3	68
BRAINSTORM	FIREBIRD	70	32	55
BRAVESTAR	GO	39	33	44
BRAX BLUFF	AMSOFT	55	1	26
BREAKTHRU	US GOLD	53	17	73

This list could not have been compiled without the assistance of Dejan Lye, who was with us for a week on work experience. We've sent him a little something to express our gratitude.

BRIAN BLOODAXE	THE EDGE	73	2	60
BRIDE OF FRANKENSTEIN	ARIOLASOFT	70	20	57
BRIDGE	INFOGRAMES	70	18	52
BRIDGE	KUMA	67	1	81
BRIDGE IT	AMSOFT	20	1	71
BRIDGE PLAYER 3	CP SOFTWARE	58	8	62
BRUCE LEE	US GOLD	88	2	53
BUBBLE BOBBLE	FIREBIRD	81	3	56
BUEBLER	ULTIMATE	75	22	59
BUGGY BOY	ELITE	70	29	52
BULLSWE	MACSEN	34	7	46
BUSTER BLOCK	KUMA	62	11	58

C

CAESARS TRAVELLERS	MIRRORSOFT	67	3	42
CAMELOT WARRIORS	ARIOLASOFT	64	16	93
CAPTAIN BLOOD	INFOGRAMES	81	34	40
CASTLE ASSAULT	BLUE RIBBON	22	6	53
CATASTROPHES	AMSOFT	66	1	78
CATCH 23	MARTECH	73	25	35
CAULDRON	PALACE	89	3	60
CAULDRON 2	PALACE	86	11	46
CAVES OF DOOM	MASTERTRONIC	66	5	58
CENTER COURT	AMSOFT	48	1	74
CENTURIONS	ARIOLASOFT	68	25	30
CHAIN REACTION	DURELL	59	31	47
CHALLENGE OF GOBOTS	ARIOLASOFT	81	22	56
CHAMONIX CHALLENGE	INFOGRAMES	68	23	62
CHAMP BASKETBALL	ACTIVISION	57	25	42
CHAMP. SPRINT	ACTIVISION	66	32	47
CHAMP WATER SKIING	INFOGRAMES	66	26	53
CHARLIE CHAPLIN	US GOLD	50	33	53
CHICKIN CHASE	FIREBIRD	64	20	60
CHIMERA	FIREBIRD	88	4	38
CHOLD	FIREBIRD	80	25	40
CHOPPER SQUAD	INTERCEPTOR	34	1	61
CHRONOS	MASTERTRONIC	45	23	48
CHUBBY GRISTLE	GRAND SLAM	59	36	45
CHUCKIE EGG	ANF	78	1	82
CITY SLICKER	HEWSON	73	16	89
CALIFORNIA GAMES	US GOLD	59	30	59
CLASSIC AXIENS	BUBBLE BUS	65	16	91
CLASSIC INVADERS	BUBBLE BUS	48	10	65
CLASSIC MUNCHER	BUBBLE BUS	69	20	49
CLEVER AND SMART	MAGIC BYTES	58	28	64
CLUEDO	LESURE GENIUS	52	8	48
COBRA	OCEAN	30	20	52
CODENAME MAT	AMSOFT	71	1	79
CODENAME MAT 2	DOMARK	74	2	48
COLOSSUS CHESS 40	CDS	92	8	70
COLOSSUS MAH-JONG	CDS	82	30	46
COMBAT LYNX	DURELL	92	1	88
COMBAT SCHOOL	OCEAN	84	28	66
COMMANDO	ELITE	76	9	62
COMPENDIUM	GREMLIN	49	30	53
COMPUTER HITS	BEAU JOLLY	88	4	50
CON-QUEST	MASTERTRONIC	73	14	60
CONTAMINATION	PSS	63	11	58
CONTRAPTION	ICON/AUDIOGENIC	72	6	50
CONVOY RAIDER	GREMLIN	55	25	31
COSMIC SHOCK ABSORB.	MARTECH	58	23	54
COSTA CAPERS	FIREBIRD	54	7	52
COUNTDOWN	MACSEN	56	9	61
COVENANT	PSS	83	2	46
CRAZY CARS	TITUS	59	33	44
CUBIT	AMSOFT	51	1	81
CURSE OF SHERWOOD	MASTERTRONIC	68	21	55
CYBERNOID	HEWSON	91	32	42
CYLU	FIREBIRD	75	7	54
CYRUS CHESS 2	AMSOFT	92	1	46

D

DALEY THOMPSON DEC	OCEAN	81	1	68
DALEY THOMPSON. DEC	OCEAN	81	4	63
DALEY THOMPSON TEST	OCEAN	85	6	44

GAMES INDEX

SPIKY HAROLD	FIREBIRD	66	10	60
SPINDIZZY	ELECTRIC DREAMS	96	6	58
SPIFFIRE 40	MIRRORSOFT	68	5	42
SPLAT!	AMSOFT	63	1	78
SPY VS SPY	FIRST STAR	90	3	52
SPY VS SPY TRILOGY	DATABYTE	81	32	52
STAINLESS STEEL	MIKRO-GEN	65	13	52
STAR FIREBIRDS	FIREBIRD	37	12	54
STAR WARS	DOMARK	44	29	56
STARFOX	ARIOLASOFT	89	24	52
STARGLIDER	RAINEIRD	91	17	50
STARION	MELBOURNE HOUSE	83	2	70
STARQUAKE	BUBBLE BUS	90	10	47
STARSTRIKE 2	REALTIME	34	12	46
STEVE DAVIS SNOOKER	CDS	63	1	38
STIFFLE AND CO	PALACE	81	28	80
STOCK MARKET SPEC.	BRAIN POWER	53	6	36
STORM	MASTERTRONIC	84	12	44
STORMBRINGER	MASTERTRONIC	88	23	46
STRAIGHT SIX	LORCIELS	60	30	54
STRANGELOOP	VIRGIN	91	4	46
STRANGELOOP PLUS	AMSOFT/VIRGIN	92	7	72
STREET FIGHTER	GO	51	34	46
STREET HAWK	OCEAN	66	15	69
STREET MACHINE	SOFT INVASION	73	17	53
STREET SPORTS BASKET	EPYX	44	36	44
STRIKE	MASTERTRONIC	49	23	52
STRIKE FORCE COBRA	PIRANHA	74	20	52
STRIKE FORCE HARRIER	MIRRORSOFT	91	7	48
STRYTE	ERE	54	22	59
STUNT BIKE SIMULATOR	SILVERBIRD	29	36	43
SUBTERR STRYKER	AMSOFT	69	2	74
SULTANS MAZE	AMSOFT	29	1	76
SUN STAR	CRL	27	25	30
SUPER CYCLE	US GOLD	71	20	51
SUPER HANG ON	ELECTRIC DREAMS	68	23	46
SUPER PIPELINE	AMSOFT	71	1	70
SUPER ROBIN HOOD	CODE MASTERS	85	18	54
SUPER SAM	JUDGIE/ALLIGATA	47	2	75
SUPER SPRINT	ELECTRIC DREAMS	73	27	51
SURPRISE-SURPRISE	CSOLUTIONS	10	7	67
SURVIVOR	ANIROG	66	1	60
SURVIVOR	US GOLD	63	26	56
SWEEVOS WORLD	GARGOYLE GAMES	90	5	48
SWORDS AND SORcery	PSS	70	9	64
SYDNEY AFFAIR	INFOGRAMMES	62	20	60

T

TAI-PAN	OCEAN	66	26	59
TALES OF ARAB. NIGHTS	INTERCEPTOR	68	4	42
TANK COMMAND	AMSOFT	81	6	34
TAPPER	AMSOFT/SEGA	69	20	51
TARGET RENEGADE	IMAGINE	86	35	38
TARZAN	MARTECH	71	17	72
TAU CETI	CRL	88	7	48
TAU CETI SPECIAL ED.	CRL	91	10	64
TECHNICIAN TED	HEWSON	82	1	58
TEMPEST	ELECTRIC DREAMS	83	14	48
TERMINUS	MAD	79	20	59
TERRA COGNITA	CODE MASTERS	80	15	80
TERRAMAX	GRAND SLAM	66	31	50
TERROR OF THE DEEP	MIRRORSOFT	34	22	50
TEST MATCH	CRL	50	1	73
TETRIS	MIRRORSOFT	72	30	56
THEATRE EUROPE	PSS	86	5	44
THAI-BOXING	ANCO	53	16	37
THANTOS	DURELL	69	16	74
THEATRE EUROPE	PSS	86	5	44
THEY SOLD MILLION 2	HIT SQUAD	86	10	64

THEY STOLE MILLION	39 STEPS	88	16	86
THRUST	FIREBIRD	94	12	52
THING BOUNCES BACK	GREMLIN	85	23	50
THING ON A SPRING	GREMLIN	82	8	50
THINK	ARIOLASOFT	80	6	47
THREE WEEKS IN PAR.	MIKRO-GEN	67	7	56
THROUGH TRAPDOOR	PIRANHA	62	29	54
THRUST 2	FIREBIRD	64	22	52
THUNDER ZONE	FIREBIRD	35	21	60
THUNDERCATS	ELITE	50	27	54
TIM LOVES CRICKET	PEAKSOFT	67	5	58
TIMELORD	ALPHA OMEGA	56	15	70
TIMETRAX	MIND GAMES	74	16	71
TOADRUNNER	ARIOLASOFT	30	10	65
TOBRUX 1942	PSS	71	11	60
TOMAHAWK	DIG INTERGRATION	92	8	60
TOMSTOWNE	AMSOFT	72	4	68
TOP GUN	OCEAN	60	17	57
TORNADO LOW LEVEL	VORTEX	90	5	48
TOUR DE FORCE	GREMLIN	20	31	45
TOURN OF DEATH	INFOGAMES	29	31	56
TOURNAMENT SNOOKER	MAGNIFICENT 7	69	8	72
TRAFFIC	AMSOFT	46	1	77
TRAILBLAZER	GREMLIN	86	15	72
TRANSMUTER	CODEMASTERS	17	27	60
TRANTOR	GO/US GOLD	80	27	56
TRAP DOOR	PIRANHA	87	16	68
TRASHMAN	VIRGIN	73	12	65
TRIAKOS	ARIOLASOFT	84	23	42
TRIO	HIT PACK	71	24	46
TRIVIA UK	ANIROG	55	2	60
TRIVIAL PURSUIT	DOMARK	68	15	62
TROLLIE WALLIE	PLAYERS	66	10	52
TROUBLE IN LT. CHINA	ELECTRIC DREAMS	64	21	49
TT RACER	DIG INTEGRATION	64	19	58
TUBARUBA	ADVANCE SOFT.P	74	6	39
TURBO ESPRIT	DURELL	81	9	60

U

UCHI MATA	MARTECH	65	20	50
ULTIMA RATIO	FIREBIRD	67	25	48

V

V	OCEAN	43	11	81
VAGAN ATTACK	ATLANTIS	55	2	30
VALUE PACK	TYNESOFT	33	2	60
VAMPIRE	CODE MASTERS	68	18	51
VENOM STRIKES BACK	GREMLIN	81	33	42
VERA CRUZ AFFAIR	INFOGRAMMES	64	14	59
VIDEO POKER	MASTERTRONIC	21	15	64
VIRGIN ATL. CHALL.	VIRGIN	50	15	63
VIXEN	MARTECH	65	35	40
VOODOO RANGE	ANTARTIC	35	10	59
VULCAN:TUNIS. CAMP.	CCS	82	21	52

W

WAR CARS CONSTR. SET	FIREBIRD	29	31	56
WAR ZONE	CCS	57	1	88
WARHAWK	FIREBIRD	49	31	40
WARLOCK	THE EDGE	64	19	51
WAY OF EXPLODING FIST	MELBOURNE HOUSE	34	1	16
WAY OF THE TIGER	GREMLIN	70	8	58

WEREWOLVES LONDON	ARIOLASOFT	66	27	51
WERNER	ARIOLASOFT	82	16	86
WEST BANK	GREMLIN	74	19	57
WESTERN GAMES	ARIOLASOFT	76	28	49
WHO DARES WINS 2	ALLIGATA	83	6	56
WISSTARS	ANF	37	19	49
WILD BUNCH	FIREBIRD	68	1	62
WILLOW PATTERN	FIREBIRD	76	3	42
WINTER GAMES	ELECTRIC DREAMS	48	6	48
WINTER GAMES	US GOLD	90	9	68
WIZARD WARZ	US GOLD	57	35	43
WIZARDS LAIR	BUBBLE BUS	82	2	38
WIZBALL	OCEAN	92	25	32
WONDERBOY	ACTIVISION	88	24	47
WORKING BACKWARDS	DESIGN DESIGN	93	7	72
WORLD CLASS LEADERB.	US GOLD	84	26	42
WORLD CUP	ARTIC	68	1	74
WORLD CUP CARNIVAL	US GOLD	1	11	56
WORLD CUP SOCCER	MACMILLAN	78	3	62
WORLD GAMES	US GOLD	70	23	52
WORLD SER. BASEBALL	IMAGINE	71	3	46
WRECKLESS ROGER	BLABY	17	6	65
WRIGGLER	ROMANTIC ROBOT	68	4	52
WRIGGLER	BLABY	76	5	40



X

XANAGRAMS	AMSOFT	33	1	82
XARG	ELECTRIC DREAMS	52	17	72
XCFI	MASTERTRONIC	80	17	64
XENO	ANF/ARGUS	78	15	76
XEVIOUS	US GOLD	57	18	46
XOR	LOGOTRON	91	26	50

Y

YIE AR KUNG FU	IMAGINE	92	4	54
YOGI BEAR	PIRANHA	66	23	55

Z

Z	RINO/ALLIGATA	74	16	84
ZANIA	MYRDINN	56	5	43
ZIGGURAT	REACTOR	73	28	54
ZOIDS	MARTECH	88	9	50
ZOMBI	UBISOFT	60	16	96
ZORRO	US GOLD	76	4	44
ZUB	MASTERTRONIC	76	16	77
ZYNAPS	HEWSON	83	24	54

ADVERTISERS INDEX

Analytical Engineering	58	M.J.C Supplies	IBC
ARC	31	Mancomp	66
Amstrad User Club	15	Matrix	66
Arnor	42	Micro Text	24
Budgetsoft	66	Mirrorsoft	37
Castle Computers	34	Nemesis	31
Cheetah	12	Ocean	IFC,3,OBC
Connect	20	Romantic Robot	47
Database	6	SDC	22
E & J Software	58	Selec	31
Galeper	66	Siren Software	20
Goldmark	48	Soft Shop	24
HSV	24	Speedysoft	66
Intermediates	58	Wacci	58
K & M Computers	26	Zenith	31

CHEER UP!
we've got you
covered!

Now for
CPC range **£8.95**



Patent pending and Registered Design

SEAL 'n TYPE™

- * Protective keyboard cover through which you can type.
- * 24hr dust/spill cover
- * Removable, washable, re-usable.
- * Can be custom-made for any keyboard. Ring for details

Ring or Write for our **FREE** catalogue

Re-inking Service	£1.90	Prices are fully incl.
Ring for transporter SAF		Cheques/P.O. payable to:
DMP re-inking kit	£10.00	KADOR
VDU Screen		Unit 4
(Colour/Mono)	£14.50	Pontcynon Industrial Estate
Mouse Mat	£5.95	Abercynon
Dust Covers		Mid Glamorgan CF45 4EP
(Colour/Mono)	£7.50	Tel: 0443 740281
Pionker Box	£4.99	Now! Authorised
Dexette Copy Holder	£6.00	Amstrad
Surge Protectors	£12.00	Dealers
Acoustic Boxes	£38.95	

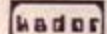

HEY!
Buy any game on this page for £6.95 on tape or £11.95 on disk. (See next page for Order Codes)

Your CPC is alive. To make sure it's kicking subscribe to *Amstrad Action*. Now!

What's really going on in the CPC world? How do you know if you're really getting the most out of your CPC? How do you get hold of the best bargains? Get all the best advice, plus tactics and games hints, pokes and help which adds new life to your existing software collection and lets you make your future choices wisely: news, features, comms, the letters pages (!) - all this by subscribing to *Amstrad Action*.

For just £16.50 you'll get the next 12 issues delivered straight from the presses to your door. And in every one of them the chance to pick up bargains you'll never see repeated elsewhere.

But that's not all. To make sure you get a proper AA kick-off we're giving away one of these four US Gold games - your copy will arrive two days after your subscription order. **But there's more!** In a moment of pure folly we're throwing in a copy of Firebird's *Enlightenment* to those who choose tape rather than disk! In other words, subscribe, pick a game from the four listed below. If you want it on tape, you get *Enlightenment* thrown in free! We can't do more than that for you. But you have to want that machine to come alive. Contact us on (0458) 74011 or fill in the order form on the next page.

Do it now!

BIONIC COMMANDOS

Normal shop price £9.99 cass, £14.99 disk

- The Capcom coin-op conversion made fierce!
- Destroy the Doomsday weapon or be destroyed!
- Five levels, each with its own soundtrack
- Five multi-loads - this is a big game!
- Take out the worlds worst ever dictator



DREAM WARRIOR

Normal shop price £9.99 cass, £14.99 disk

- Set in a dream where you must never wake up
- Go round collecting the sleeping pills to stay in the game
- Kill the monster at the end of your nightmare and you've won!



ROAD BLASTERS

Normal shop price £9.99 cass, £14.99 disk

- Faster than *Outrun!*
- Take it to the limit in your custom road warrior car



- Just blast everything else on the road and in the sky!
- Loads of sections!
- Loads of helicopters and death merchants out to get you if you can't play!

CHARLIE CHAPLIN

Normal shop price £9.99 cass, £14.99 disk

- A super game for everyone from 7 upwards
- Direct a movie and control the Stars!

- Select a script, shoot a scene, then edit it
- Show it to an audience and listen to them clap!



ANY ONE OF THESE PROGRAMS FREE WHEN YOU SUBSCRIBE!
Or buy them separately for just £6.95 cass, £11.95 disk.

THE AMSTRAD ACTION SPECIAL OFFERS SECTION

SOFTWARE CODES LIST

ITEM	OUR PRICE	ORDER CODE
SUBSCRIPTION		
with BIONIC COMMANDO cass* ...	£16.50	A340
with BIONIC COMMANDO disk...	£16.50	A341
with ROAD BLASTERS cass* ...	£16.50	A342
with ROAD BLASTERS disk...	£16.50	A343
with CHARLIE CHAPLIN cass* ...	£16.50	A344
with CHARLIE CHAPLIN disk...	£16.50	A345
with DREAM WARRIOR cass* ...	£16.50	A346
with DREAM WARRIOR disk...	£16.50	A347
*Cass options include ENLIGHTENMENT on tape as free extra.		
SOFTWARE ON ITS OWN		
BIONIC COMMANDO CASS	£6.95	A348
BIONIC COMMANDO DISK	£11.95	A349
WIZARD WARS CASS	£6.95	A350
WIZARD WARS DISK	£11.95	A351
CHARLIE CHAPLIN CASS	£6.95	A352
CHARLIE CHAPLIN DISK	£11.95	A353
DREAM WARRIORCASS	£6.95	A354
DREAM WARRIOR DISK	£11.95	A355
TARGET RENEGADE CASS	£6.95	A356
TARGET RENEGADE DISK	£11.95	A357
AT LAST PLUS CPM DISK	£29.95	AA353

**Firebird's
ENLIGHTENMENT**
(Druid II) - just £3.95 (RRP
£8.95)

**Just £3.95 -
only through
Amstrad
Action!**

ENLIGHTENMENT, the game which subscribers get free of charge when they choose a tape rather than a disk game, is now available to all **Amstrad Action** readers for just **£3.95**. It's a Firebird game which was released in April of this year with the full title of *Enlightenment Druid II*. Complete with 22 page manual/initiation booklet, *Druid II* follows the quest for magical powers in the context of an icon-driven adventure which won praise from both adventurers and those more used to arcade action.

Definitely a long-term project which will challenge your wisdom!
Order Code AA352

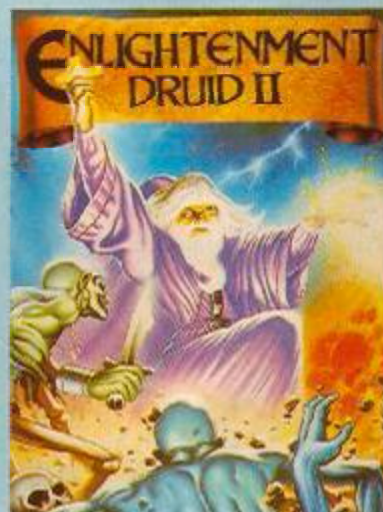

● ORDER FORM No. 36 ●

Name _____

Address _____

Postcode _____

Tel Number (If possible) _____ Date of Order _____

Please send me the following item(s) from the Amstrad Action Special offer pages:

CODE	DESCRIPTION	PRICE

Make cheques & postal orders payable to FUTURE PUBLISHING LTD. If paying by credit card please enter details

CREDIT CARD NUMBER

EXP. DATE

**Send this form plus payment to SPECIAL OFFERS AMSTRAD
ACTION SOMERTON SOMERSET TA117PY**

**HOTLINE
PHONE
0458 74011**



**Imagine's
TARGET RENEGADE**

**£6.95 (RRP £8.95)
£11.95 disk (RRP
£14.95)**

Yes! The August AA Mas-tergame comes into the Special



Offers section. Basically a Taito coin-op conversion, *Target Renegade* is set in the world of the vigilante where there is only one man who can challenge the rule of evil - and there's a price on his head! An all-action arcade classic which will set your CPC alight.

Go for it - if you dare!
**Order Code AA356 (tape) /
AA357 (disk)**

HACKERS HANDBOOK III
 by Hugo Cornwall
£6.95 • Century Hutchinson

Here it is! The Know-All book about hacking - the art of exploring other people's computer systems - that will shock you with its frankness. When *The Hackers Handbook* first appeared in 1985 it caused a storm of interest and went straight into the best-seller lists because it revealed so much about the way computer systems across the world operate. This updated edition shows that as computers emerge further into mainstream life, the aspect of computer security has been thrust into the foreground of political, legal, military and business life.

Hackers Handbook III looks at modems, Prestel-type information systems and networks. It discusses some of the most famous incidents of the last ten years, from the Prince Phillip mailbox hack of 1984 to the millions of pounds that are lost by the banks and building societies annually. All together, a fabbo read which will get your brain twitching frantically!

Order Code AA343



HIGH-LIGHTER PENS

Three for £1.50

Anyone who uses computers a lot, can make use of highlighter pens. For marking the important lines in a document or printout or program listing. For ensuring a key sentence in a manual isn't forgotten. Or just for highlighting the main points in an Amstrad Action article.

We're offering a set of three different-coloured AA-stamped pens in a clear plastic wallet for just £1.50. They're high-quality and long-lasting. A good way of focussing attention on things that matter.

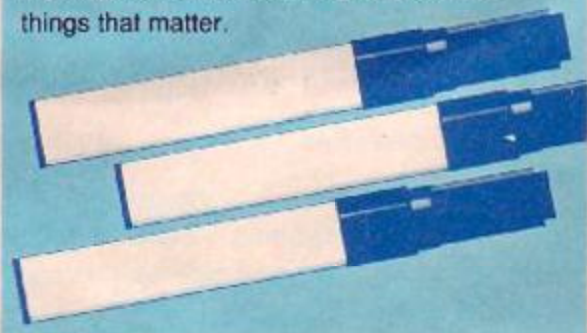

A VERY SPECIAL OFFER!

Amstrads and Artificial Intelligence
 by Patrick Hall
Just £1.95 (RRP £8.95!)

Published by Sigma Press, this book looks in detail at one of the most talked-about topics of our generation - artificial intelligence. Is it really possible to build a computer program that comes anywhere near the capabilities of the human brain?

Amstrads and Artificial Intelligence isn't a philosophy book though - it's a book that discusses the requirements of AI AND offers several program listings that allow you to start tackling the issues at the practical level. Didn't think you could get AI on your CPC? Well think again - then buy this book. Topics include expert systems, computer vision, robots and learning, game playing and knowledge representation. All this for just £1.95 - saving SEVEN POUNDS on the original price! An excellent book for anyone who owns a CPC and wants to take it further than ever before.

Order Code A895

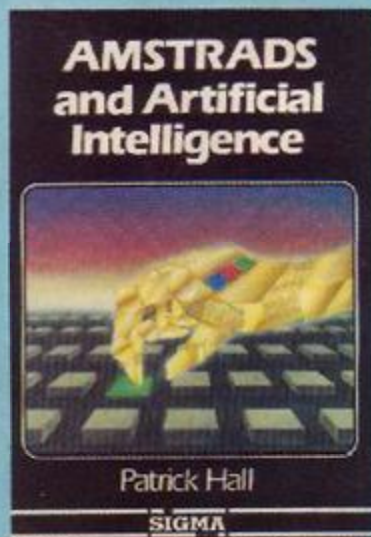

HOW TO ORDER

Just use the order form on the left hand page. Use the order numbers listed with the product, OR, for a subscription, look at the Subscriber Code box next to the Order Form.

Otherwise telephone us with your credit card details on 0458 74192 (24-hour answerphone).

ATLAST PLUS
CP/M database program for the CPC6128 for just £29.95 (RRP £39.95)

"Superb value for money and hard to pick holes in" we called the first version of *AtLast*. Now, with the release of *AtLast Plus* by Rational Solutions, you have the chance of buying one of the best (and probably *the* best for the 6128) databases for £29 - £10 less than the full retail price!

AtLast Plus runs under CP/M, and features include up to 32,000 records, ten files per database, 20 fields per record, 99 elements per field and up to 79 characters per element. User-definable report and screen layouts, full on-screen control of data entry, impressive indexing/sorting facilities and automatic data re-organisation are all included in this latest version. As well as this, unused data space is not saved to disk marking out *AtLast Plus* as an essential database for serious 6128 owners.

The package includes disk and full 120 page manual - altogether one of the most suitable programs for organising club-type membership lists, and unbeatable value for money - only through *Amstrad Action*.

Order Code AA353

BACK ISSUES

Expand your Amstrad Action collection!

If you're one of the thousands of readers who've joined Amstrad Action only recently, you'll want to catch up on some of the good things you've missed. Here's how to do it. We have limited numbers of the back issues listed below, which we're selling at cover price with post and packing free.

Issues 8 and 16 may be of particular interest, as both include free cassettes packed with good software. Two series also went down very well. Andrew Wilton's programming course in Basic for absolute beginners ran from issues 8-17, while a series of articles on the CP/M operating system ran from 10-17.

All issues contain numerous game reviews, Type-Ins and Pokes, all making up the best in Amstrad action past and present.

ISSUES 1-6 SOLD OUT!

ISSUE 7 • £1.00 • Educational software reviewed. Tips on Elite.

ISSUE 8 • £1.50 • COVER CASSETTE containing the complete PSS game (an AA Rave) The Covenant.

ISSUE 9 SOLD OUT

ISSUE 10 SOLD OUT!

ISSUE 11 • £1.00 • Pokes for Batman, Bounder, The Covenant, Tau Ceti.

ISSUE 12 • £1.00 • Big disc drives, Starstrike II, Programming Pascal.

ISSUE 13 • £1.00 • 7-page music special, Knight Tyme playing guide.

ISSUE 14 • £1.00 • Art Studio review, maps of Dan Dare, Price of Magik.

ISSUE 15 SOLD OUT!

ISSUE 16 SOLD OUT!

ISSUE 17 • £1.00 • Pagemaker review, Red Boxes review. Numerous Type-ins.

ISSUE 18 SOLD OUT!

ISSUE 19 • £1.00 • Cheat Mode special. ROMs and EPROMs.

ISSUE 20 • £1.00 • Survey of ingenious gadgets and add-ons.

ISSUE 21 • £1.25 • Type-ins special including Card Trick program.

ISSUE 22 • £1.25 • Head Over Heels Poke + 5-page playing guide.

ISSUE 23 • £1.25 • Launch of Word-Processing series. Utility Type-ins.

ISSUE 24 • £1.25 • Reviews of Tas Sign, Pocket Protext, Exolon.

ISSUE 25 • £1.25 • Create your own Trivia quiz program. RODOS reviewed.

ISSUE 26 • £1.25 • Special on Midi music interface.

ISSUE 27 • £1.25 • Midi and Teletext. Build an RS232. Red L.E.D.

ISSUE 28 • £1.25 • Special Christmas tape! Learning Basic and assembly language.

ISSUE 29 • £1.25 • Six top printers reviewed. Spreadsheets.

ISSUE 30 • £1.25 • Discovering databases. How to upgrade a 464 to a 6128.

ISSUE 31 • £1.25 • CP/M software section starts. Basic programming reaches part five.

ISSUE 32 • £1.25 • Educational software survey. CP/M on ROM feature. Word processing.

ISSUE 33 • £1.25 • Loads of hardware projects! - joystick, splitter, I/O port etc. Comms round-up.

ISSUE 34 • £1.25 • CPC's for small business. Simulation software from space shuttles to bikes reviewed.

ISSUE 35 • £1.25 • The joy of hacking scrutinised! Do sequels work? A buyers guide to computer books.

AA DUST COVERS

2-piece set only £6.95

Let's face it, computers don't like dust. Over a period of time it can make them very ill indeed: disk drives and cassette decks in particular can suffer serious, sometimes fatal damage.

A set of dust covers provides a neat solution. And there's the added bonus of smartening up the hardware's appearance when it's not in use.

The specially-commissioned Amstrad Action covers are made from high-quality, water (and coffee) proof PVC. They're coloured a gentle beige with smart blue trimming and matching AA logo.

You can order a 2-piece set tailor-made for your CPC system - just choose the correct order code from the list next to the order form.

Order Codes

464 mono - A208	664 colour - A211
464 colour - A209	6128 mono - A212
664 mono - A210	6128 colour - A213

24 HOUR

CREDIT CARD ORDERS

0458 74192

THE THING!

Only £5.95 - save £2!

What's white, dangles paper next to your computer screen, and costs two pounds less than in the shops? Yes, a Thing! bought through Amstrad Action.

This remarkable computer accessory - an idea so simple it's ingenious - could dramatically ease your hours at the keyboard. It's basically a cleverly-shaped piece of plastic that attaches via Velcro to the top of your micro. But with a Thing! on your CPC you can have documents, letters or program listings clipped right next to the screen in perfect reading position.

Any task involving copying off paper is thereby made much easier and faster. In fact, the coloured clip supplied is sturdy enough to support an issue of Amstrad Action open, say, at the Type-ins section.

The Thing! comes in two versions, one for positioning to the left of the screen, the other to the right - the Velcro attachment allows easy readjustment or temporary removal.

A sensible, cost-effective add-on for your CPC.

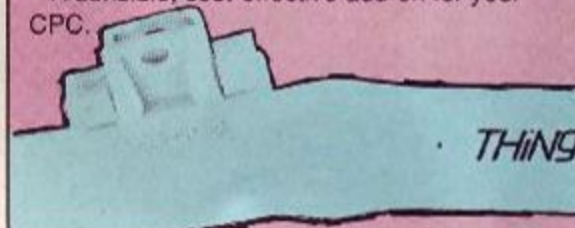

DISCOUNT SOFTWARE

from M.J.C. SUPPLIES

DISC GAMES

ATF	11.95
Arcade Force Four	16.95
Beyond The Ice Palace	11.95
Captain Blood	11.95
Cholio	14.95
Colossus Mah Jong	11.95
Colossus 4 Chess	11.95
Combat School	11.95
Computer Classics	11.95
Conflicts	14.95
Dark Side	11.95
Dragons Lair II	11.95
Driller	14.95
Druid II	11.95
Elite	10.95
F15 Strike Eagle	11.95
Football Manager II	11.95
Gary Linekers Soccer	11.95
Gryzor	11.95
Impact	11.95
Int. Karate II	11.95
Karnov	11.95
Konami Arcade Collect	14.95
Live Ammo	11.95
Lucas Film Collection	11.95
Mag Max	11.95
Magnificent Seven	14.95
Matchday II	11.95
Monopoly	11.95
Overlander	10.95
Pirates	14.95
Platoon	11.95
Prohibition	11.95
Renegade	11.95
Revenge Of Doh	11.95
Scrabble Deluxe	12.95
Six Pack III	11.95
Spy Vs Spy	11.95
Starglider	16.95
Star Wars	11.95
Street Fighter	12.95
Target Renegade	11.95
Tetris	11.95
The Pawn 6128	16.95
ThunderCats	11.95
Time and Magik	11.95
Trivial Pursuits	16.95
Venom Strikes Back	11.95

MJC SPECIAL

Gunship
RRP 14.95 OURS 9.95

EDUCATION

Animal Veg, Mineral	11.95
Answerback JNR Quiz	11.95
Factfile Arithmetic	7.95
Factfile Spelling	7.95
Factfile Sports	7.95
Fun School 2-5 years	7.95
Fun School 5-8 years	7.95
Fun School 8-12	7.95
World Wise	11.95

MJC SPECIAL:

Dark Side
RRP £14.95 OURS £9.95

Note: Factfiles are extra question packs for the Answerback JNR Quiz

DISC SERIOUS

Qualitas Plus	12.95
Rodos Extra disc	8.95
Spanish Tutor	16.95
French Mistress	16.95
German Master	16.95
Maxam ass/diss	21.95
Prospell	20.95
Promerge	20.95
Tasword 6128	19.50
Taspell	12.95
Tasprint	10.95
Tascopy	10.95
Tasdiary	10.95
Tassign 6128	23.95
Matrix Spreadsheet	29.95
Mastercalc 128	28.95
Masterfile	32.95
Mini Office II	15.95
Advanced Music System	25.95
Advanced Art Studio	19.95
Arnor Filer	21.95
Arnor Office Suite	29.95
Stop Press	39.95

CPM BASED

Supercalc 2	41.95
Dr Graph	39.95
Dr Draw	39.95
Dr CBasic	35.95
Dr Pascal MT+	35.95
Arnor C Compiler	39.95
Maxam II	39.95
Nevada Fortran	35.95
Nevada Cobal	39.95
Nevada Lisp	18.95
Hisoft Devpac 80	39.95
Hisoft Pascal 80	39.95
Hisoft C Compiler	39.95
lankey 2 Finger Typing	19.95
lankey Crash Course	19.95

MJC SPECIAL

Protex CPM: including
Spellchecker & Mailmerge
RRP £59.95 OURS £39.95

CASSETTE BASED

Maxam 464	16.95
Protex 464	16.95
Tasword 464	15.95
German Master 464	14.95
French Mistress 464	14.95
Answerback JNR Quiz	8.95
Factfile Arithmetic	4.50

ACCESSORIES

Multiface II (Rom)	41.95
Printer Lead 1M	8.95
Printer Lead 1.5M	9.95
Printer Lead 2.0M	10.95
3" Disc Cleaner	6.95
Amstrad RS232 interface	55.95
Mono Screen filter	12.95
Colour Screen Filter	14.95
Comp Pro 5000 joystick	13.95
Quickshot Turbo Joystick	11.95
Cruiser Joystick	9.95
6128 Light Pen	26.95
464 Monitor Ext Leads	6.95
6128 Mono Ext Leads	7.95
Amstrad V21/23 Modern	95.95
1000 Fanfold Labels	5.95
Second Drive Lead	7.95
DKT 64K Memory Exp	44.95
AMS 20L Disc Box	9.95
AMX Mouse + Art	65.95
AMX Mouse + Stop Press	75.95
464 Dust Cover (Mono/Col)	7.95
6128 Dust cover	7.95

BOOKS/MANUALS

Intro to CPM+	7.95
Adv Amstrad Graphics	7.95
Mastering Machine Code	8.95
The Amstrad CPM+ Book	12.95
128 Firmware Spec (968)	18.95
Programming the Z80	19.95

SPECIALS

DMP 2000 Ribbons	
x 2	7.00
x 5	16.00
DMP coloured Red, Blue	3.95
Genuine Amsoft CF2 Disc	
x 5	12.00
x 10	22.95
x 20	42.95

ROM BASED

Maxam	31.95
Maxam 1.5	23.95
Protex	31.95
BCPL	23.95
Utopia	23.95
Prospell	28.95
Promerge+	28.95
Rodos	28.95
Cage Rom (State which I/Face)	31.95
Rombo (if purchased with Rom)	28.95
KDS Rom Board (Holds 6)	25.95

M.J.C PACKAGES

Qualitas Plus
KDS 8 Bit Port
Display Font Pack
R.R.P £44.45
Package Price £34.95

CORNIX SOFTWARE

CARD INDEX: Easy to use filing system
CASS: 19.95
DISC: 24.95

SIMPLE ACCOUNTS: easy to use accounts ideal for small business includes VAT.
CASS: 34.95
DISC: 39.95

JOB ESTIMATOR: useful tool for contractors.
DISC: 39.95

PRODUCT COSTING: DISC: 39.95
Full specifications on all of the above programs on request.

PRINTERS

MP-135 Printer; 80 column, 135 CPS
Friction & tractor feed, Epson comp.
MJC PRICE £149.95

DMP 2160 Printer: £159.95

Panasonic 1081: 80 column, 120 CPS
Friction & Tractor feed, Epson comp.
MJC PRICE £169.95

MP-200 Printer: 80 column, very fast
240 CPS, Fric & Tractor, Epson comp.
MJC PRICE £279.95

MP-201 Printer;
wide 136 column, fast
240 CPS, Fric & Tractor, Epson comp.
MJC PRICE £349.95

STAR LC 10 PRINTER: 144cps, with front panel font selection
£195.95

STAR LC10 COLOUR: 144cps, with front panel font selection, seven colour option. £239.95

ALL ABOVE PRICES INCLUDE VAT, POSTAGE & PACKING IN THE U.K

THE ABOVE SOFTWARE IS ONLY FOR THE AMSTRAD CPC RANGE
PCW AND PC OWNERS PLEASE WRITE FOR DISCOUNT PRICES

Overseas Orders Welcome - Please write for details

WE ARE NOW IN OUR FOURTH YEAR OF SPECIALISING IN AMSTRAD MAIL ORDER, OUR POLICY IS TO PROVIDE THE WIDEST RANGE AT DISCOUNT PRICES WITH A FAST TURN AROUND TIME - TRY OUR SERVICES WITH CONFIDENCE

CALLERS WELCOME: Mon-Fri 9 to 5 Sat 10 to 4

PLEASE SEND CHEQUES/POs TO:

M.J.C SUPPLIES, (AA)

40a Queen Street, Hitchin, Herts. SG4 9TS.

Tel: (0462) 32897/420847 for enquiries/Credit Card orders



TYPHOON



KONAMI
COIN-OP ACTION

TYPHOON



Soar through wave after wave of flying death in your armour-laden helicopter, scream through the skies in your F-14 as you take on the seemingly limitless hordes of mechanoid invaders, whose sole intent is total domination of the Earth. The storm is raging as the

war is fought in the skies. TYPHOON - the Konami coin-op now for your home micro featuring fast scrolling and 3-D, frenzied dog-fighting, accumulate a vast array of deadly weapons. Six levels of pulse pounding excitement. Each culminating in a devastating adversary.



CASSETTE

COMMODORE
AMSTRAD

£8.95

SPECTRUM

£7.95

DISC

AMSTRAD

£14.95

COMMODORE

£12.95

